

## Cork Extraction Test Rig



### Description

The cork extraction test rig is used to test the extraction force of bottle stoppers. It has a bottle cradle with an antislip surface and is easily adjusted to accommodate different bottle heights, e.g. 200 ml to 750 ml. It is used in conjunction with corkscrew test accessories suitable for testing natural and synthetic corks.

### Applications

Used for extraction testing of:

- corks
- stoppers



### Specifications

Part No.	Load Capacity	Thread 1	Loop Diameter Ø	Length
PDV11086	1 kN / 100 kgf / 225 lbf	4x M5	13 mm (0.51")	450.5 mm (17.74")

# Dimensions mm (inch)

ALL DIMENSIONS ARE IN MILLIMETRES  
FOLLOWED BY INCHES: MM ( IN" )

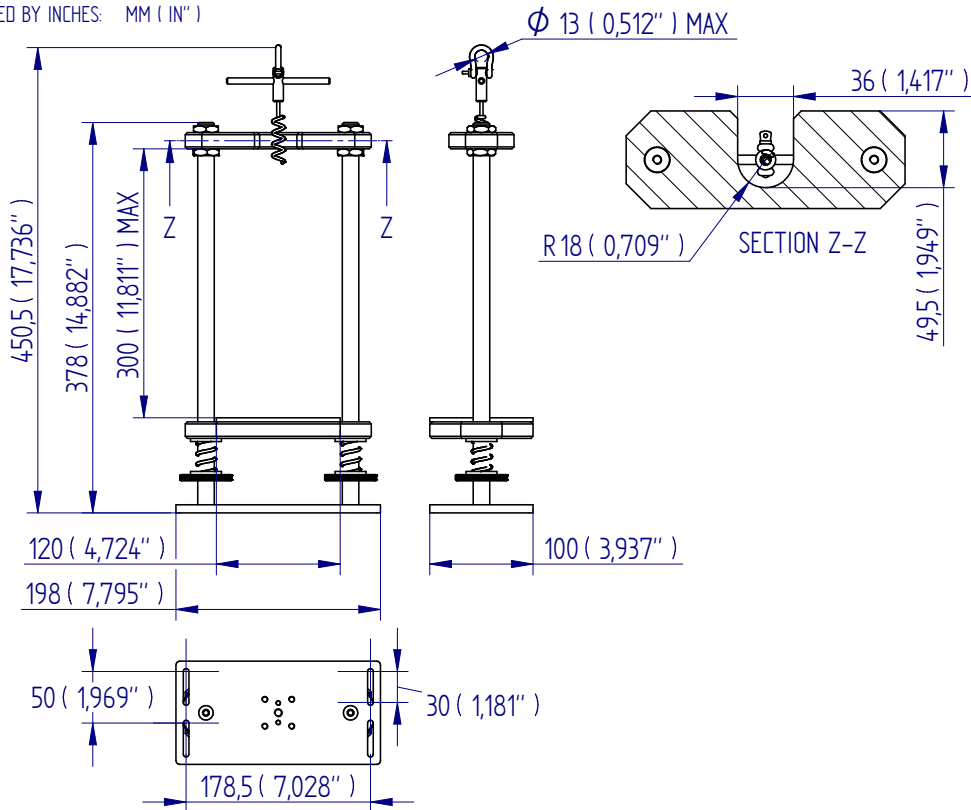

FS 58553

Mecmesin reserves the right to alter equipment specifications without prior notice.  
E&OE

**Head Office**  
**Mecmesin Limited**

w: [www.mecmesin.com](http://www.mecmesin.com)  
e: [sales@mecmesin.com](mailto:sales@mecmesin.com)

**France**  
**Mecmesin France**

w: [www.mecmesin.com/fr](http://www.mecmesin.com/fr)  
e: [contact@mecmesin.fr](mailto:contact@mecmesin.fr)

**Germany**  
**Mecmesin GmbH**

w: [www.mecmesin.com/de](http://www.mecmesin.com/de)  
e: [info@mecmesin.de](mailto:info@mecmesin.de)

**North America**  
**Mecmesin Corporation**

w: [www.mecmesin.com](http://www.mecmesin.com)  
e: [info@mecmesincorp.com](mailto:info@mecmesincorp.com)

**Asia**  
**Mecmesin Asia Co., Ltd**

w: [www.mecmesin.com/th](http://www.mecmesin.com/th)  
e: [sales@mecmesinasia.com](mailto:sales@mecmesinasia.com)

**China**  
**Mecmesin (Shanghai) Pte Ltd**

w: [www.mecmesin.com/zh](http://www.mecmesin.com/zh)  
e: [sales@mecmesin.cn](mailto:sales@mecmesin.cn)