

Pull Peel Wheel Fixture



Description

The pull peel wheel fixture is designed for mounting to the base of a motorised test stand to test the peel strength of flexible adhesive-backed materials. Samples are wound around the wheel and the free end is clamped in a suitable upper grip connected to a loadcell. The minimal-friction bearing ensures a constant 90° peel angle.

Applications

Used for peel testing of:

- laminated coatings
- adhesive-backed tape
- adhesive-backed films and foils

Specifications

Part No.	Load Capacity	Post Ø	Rim Width	Wheel Diameter Ø	Height	Weight
432-265	200 N / 20 kgf / 44 lbf	QC-20	25.4 mm (1.0")	152.4 mm (6.0")	212 mm (8.34")	246 g (0.54 lb)

Dimensions mm

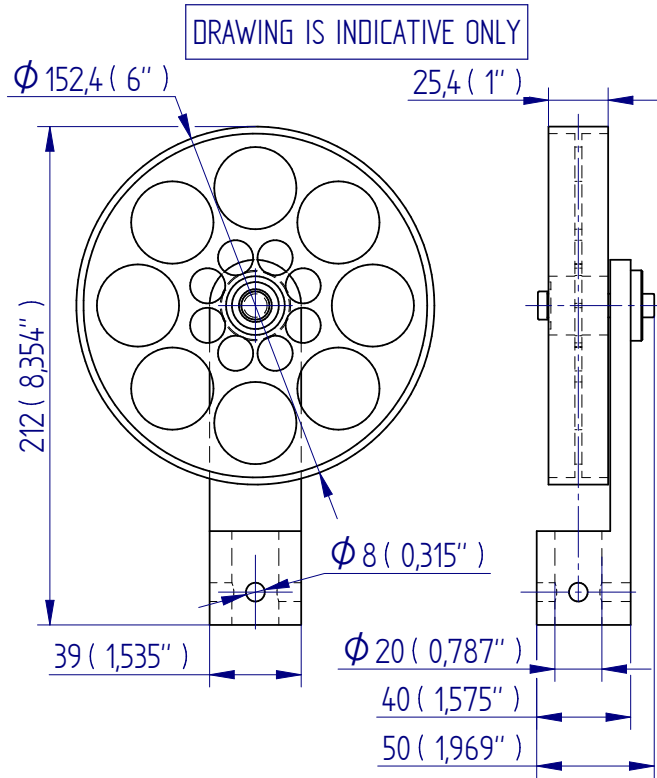

For more information on QC fittings, refer to datasheet 431-354
Adapters for QC range of grips.



FS 58553

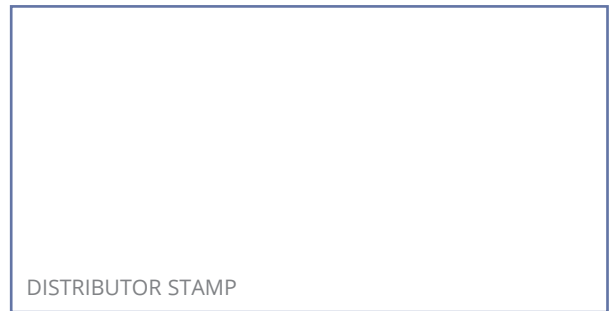

Mecmesin reserves the right to alter equipment specifications without prior notice.
E&OE

Head Office
Mecmesin Limited

w: www.mecmesin.com
e: sales@mecmesin.com

France
Mecmesin France

w: www.mecmesin.com/fr
e: contact@mecmesin.fr

Germany
Mecmesin GmbH

w: www.mecmesin.com/de
e: info@mecmesin.de

North America
Mecmesin Corporation

w: www.mecmesin.com
e: info@mecmesincorp.com

Asia
Mecmesin Asia Co., Ltd

w: www.mecmesin.com/th
e: sales@mecmesinasia.com

China
Mecmesin (Shanghai) Pte Ltd

w: www.mecmesin.com/zh
e: sales@mecmesin.cn