

FPT-H1 50 mm Peel Grip (FINAT 3), QC fitting

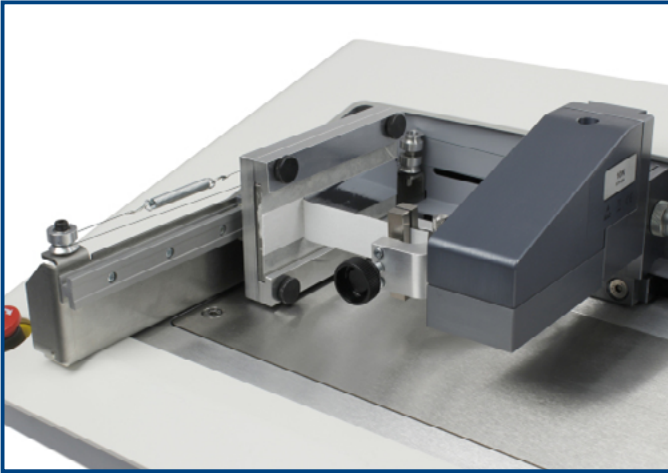

90° peel of laminated card (with part no. 432-620)▲

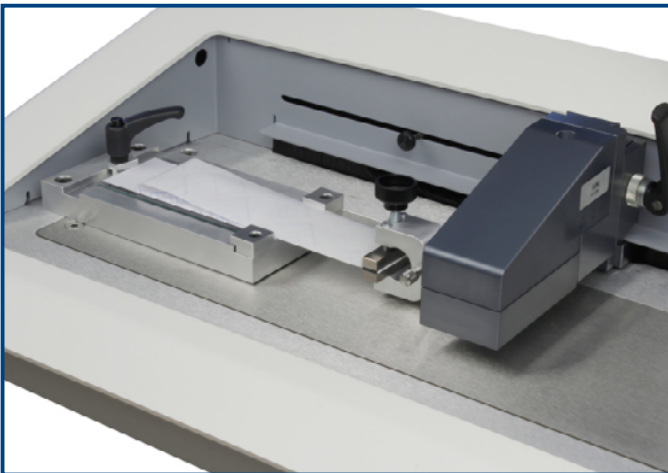

180° peel of self-adhesive labels (with part no. 432-636) ▲

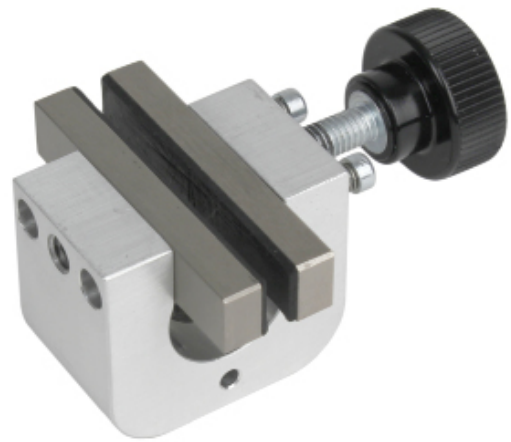

Description

The Mecmesin FPT-H1 horizontal coefficient of friction tester can also be used for specific standard peel and tear test methods. This peel grip can be used in conjunction with the FPT-H1 90 degree fixture kit (part no. 432-620) or the FPT-H1 180 degree peel fixture kit (part no. 432-636) where the drawn part of the sample is non-adhesive, in place of the standard hook fixture.

This single-action grip has rubber-faced jaws for securely gripping backing layers, plastic film, paper and card. Supplied as a single grip.

Suitable for test standards FINAT FTM1, 2 & 3; ASTM D3330, D6252, TLMI L-IA1 & 2

Specification

Part no.	Jaw opening	Jaw width	QC Ø
432-654	4 mm	50 mm	8 mm

Dimensions mm

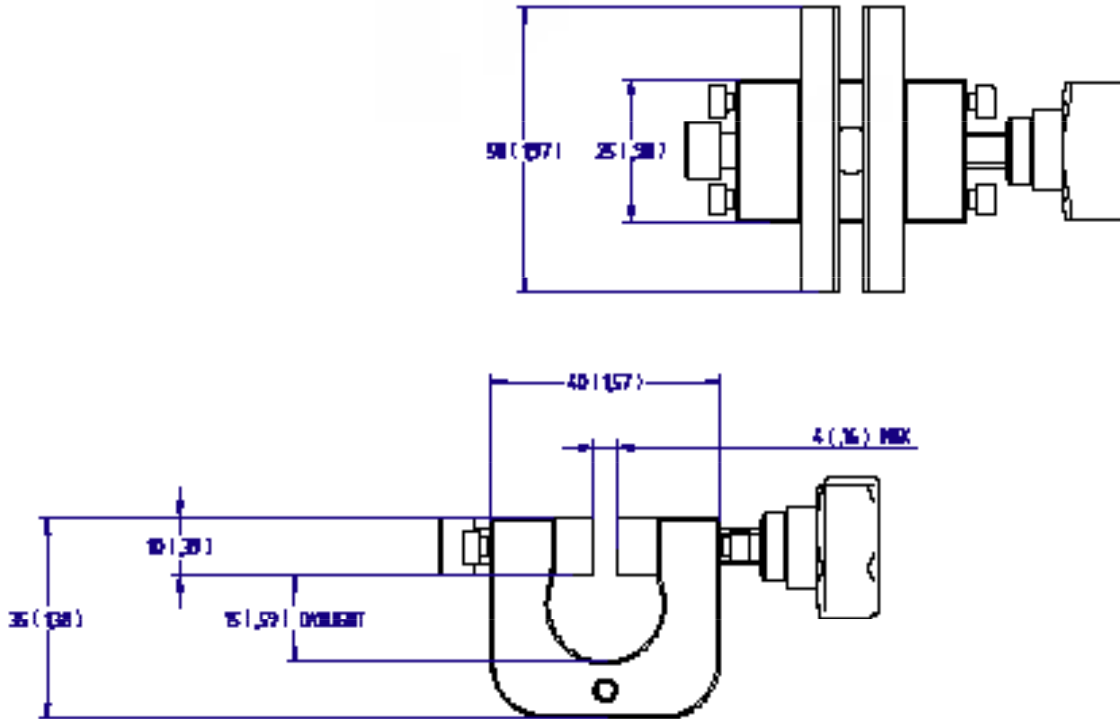

FS 58553

Mecmesin reserves the right to alter equipment specifications without prior notice.
E&OE

Head Office
Mecmesin Limited

w: www.mecmesin.com
e: sales@mecmesin.com

France
Mecmesin France

w: www.mecmesin.com/fr
e: contact@mecmesin.fr

Germany
Mecmesin GmbH

w: www.mecmesin.com/de
e: info@mecmesin.de

North America
Mecmesin Corporation

w: www.mecmesin.com
e: info@mecmesincorp.com

Asia
Mecmesin Asia Co., Ltd

w: www.mecmesin.com/th
e: sales@mecmesinasia.com

China
Mecmesin (Shanghai) Pte Ltd

w: www.mecmesin.com/zh
e: sales@mecmesin.cn