

## 2 mm Needle Probe

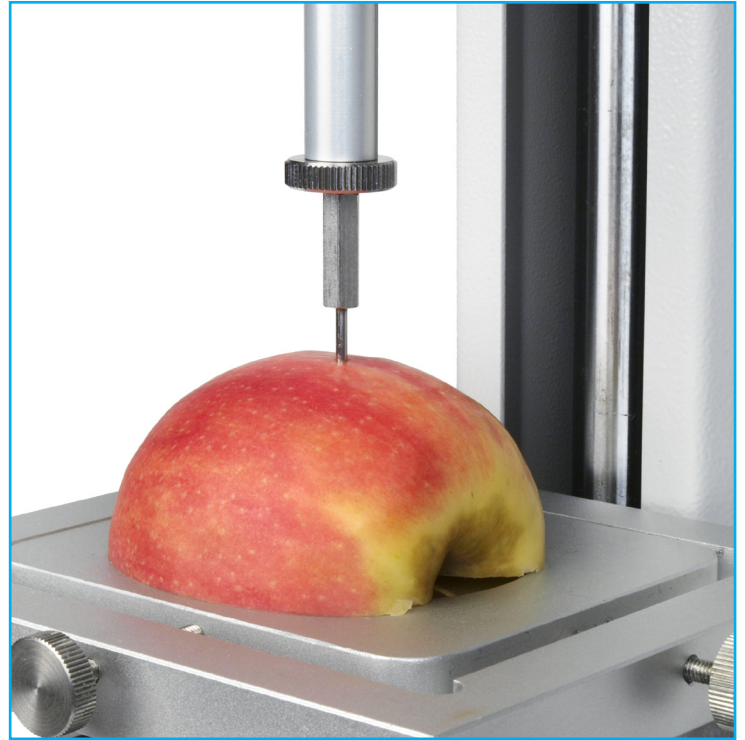

### Description

The needle probe is made from stainless steel and is designed for surface puncture and penetration tests. Attach to the loadcell with 432-100 Extension Rod.

### Applications

Used to determine the penetration resistance, firmness and spreadability properties of:

- food products
- solid cosmetics products



◀ 432-100 Extension Rod with securing thumbwheel fitted to M3 thread.

### Specifications

Part No.	Description	Load Capacity	Thread 1	Thread 2	Weight
432-087	2 mm Needle Probe	100 N / 10 kgf / 22 lbf	M3	N/A	9 g (0.02 lb)
432-100	Extension Rod	100 N / 10 kgf / 22 lbf	10-32 UNF	M3	40 g (0.09 lb)

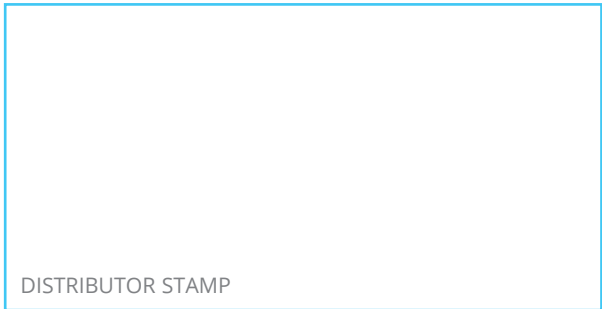
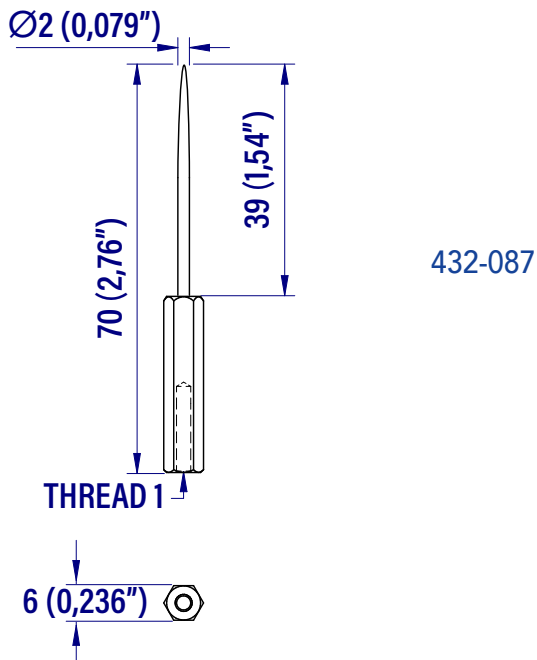
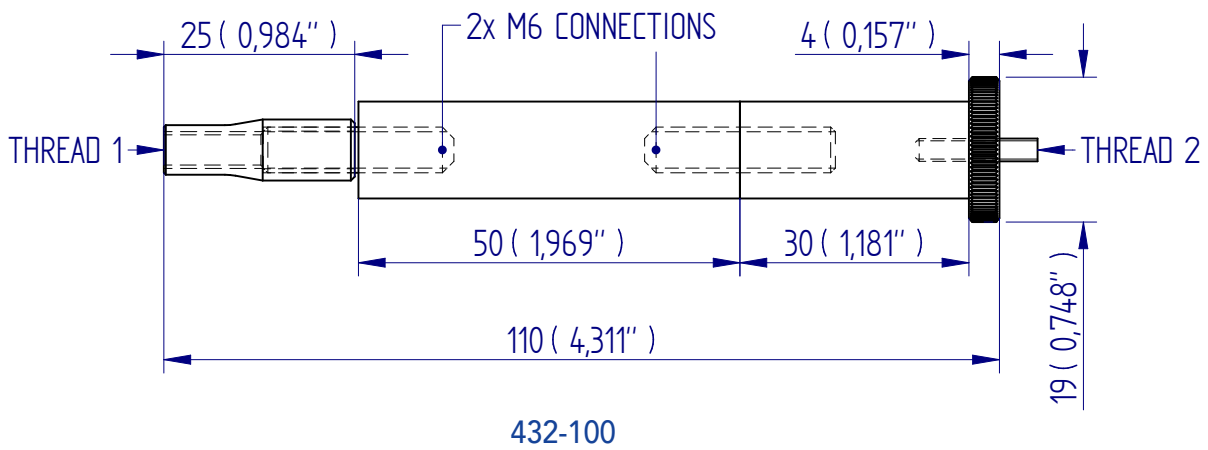

Mecmesin reserves the right to alter equipment specifications without prior notice.  
E&OE

**Head Office**  
Mecmesin Limited

w: [www.mecmesin.com](http://www.mecmesin.com)  
e: [sales@mecmesin.com](mailto:sales@mecmesin.com)

**France**  
Mecmesin France

w: [www.mecmesin.com/fr](http://www.mecmesin.com/fr)  
e: [contact@mecmesin.fr](mailto:contact@mecmesin.fr)

**Germany**  
Mecmesin GmbH

w: [www.mecmesin.com/de](http://www.mecmesin.com/de)  
e: [info@mecmesin.de](mailto:info@mecmesin.de)

**North America**  
Mecmesin Corporation

w: [www.mecmesin.com](http://www.mecmesin.com)  
e: [info@mecmesincorp.com](mailto:info@mecmesincorp.com)

**Asia**  
Mecmesin Asia Co., Ltd

w: [www.mecmesin.com/th](http://www.mecmesin.com/th)  
e: [sales@mecmesinasia.com](mailto:sales@mecmesinasia.com)

**China**  
Mecmesin (Shanghai) Pte Ltd

w: [www.mecmesin.com/zh](http://www.mecmesin.com/zh)  
e: [sales@mecmesin.cn](mailto:sales@mecmesin.cn)