

Owner's Manual

Media Manager V2 Lectern

LH Drawer	RH Drawer	
55236	55237	Standard Media Manager V2
55242	55243	with Overbridge Control Console

Touchboards

205 Westwood Ave, Long Branch, NJ 07740
Phone: 866-94 BOARDS (26273) / (732)-222-1511
Fax: (732)-222-7088 | E-mail: sales@touchboards.com

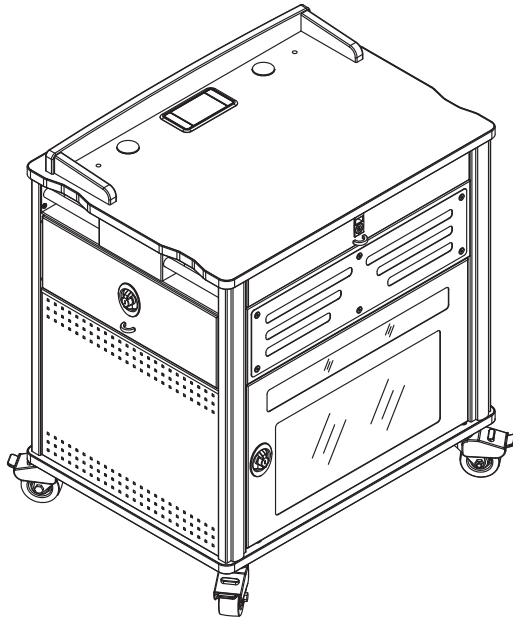

Standard Media Manager V2
with LH drawer, Heavy-Duty casters & surround
55236HDS

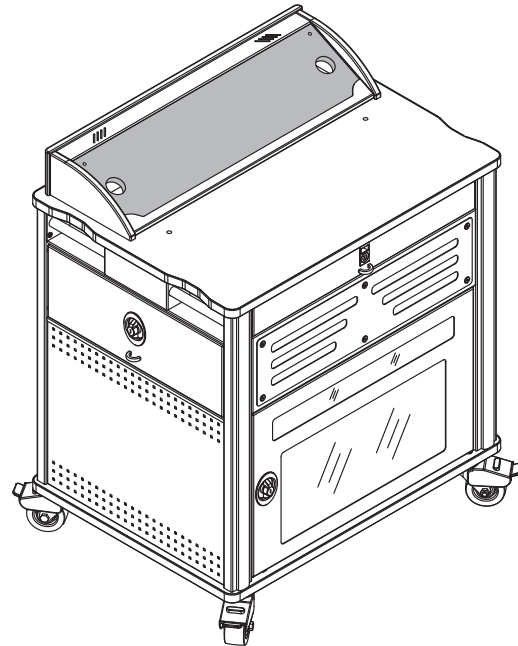

Media Manager V2 with Overbridge Control Console,
LH drawer & Heavy-Duty casters
55242HD
shown with optional insert panel (shaded)

CAUTION:

Before using this product, read this manual and follow all safety and operating instructions.

Before you begin, please make sure all parts and proper quantities are included. Any parts damaged during shipment must be reported within 15 days of receipt. To report information regarding damages or if you have any questions, please call 1-800-235-1262.

To purchase parts or accessories, please contact us at
www.spectrumfurniture.com
1-800-235-1262

Thank you for purchasing Spectrum products!



Spectrum Industries, Inc
Chippewa Falls, WI 54729, USA

! Safety !

- Read this owner's manual before assembly or operation.
- Do not allow children to move lectern.
- Move slowly and carefully when mobile.
- For indoor use only. Do not install or store the lectern where it will be exposed to weather. Keep dry.
- For added safety, plug the lectern into a grounded three-prong receptacle controlled by a GFI (Ground Fault Interrupter) circuit breaker.

Assembly / Setup

Flip-up shelf operation

1. Shelf will automatically lock into place when lifted into the horizontal position with the levers released. **Figure 1A.**
2. To lower or flip-up the shelf, press and hold the lever under each folding shelf bracket at the same time while slowly lowering or raising the shelf. **Figure 1B.**
3. Do not exceed a maximum of 50 lbs of weight on the shelf. Do not move the lectern while the shelf is in the horizontal position.

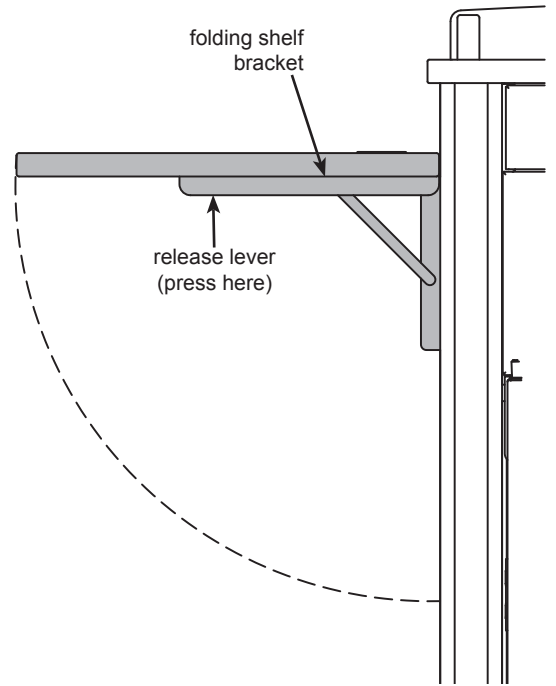
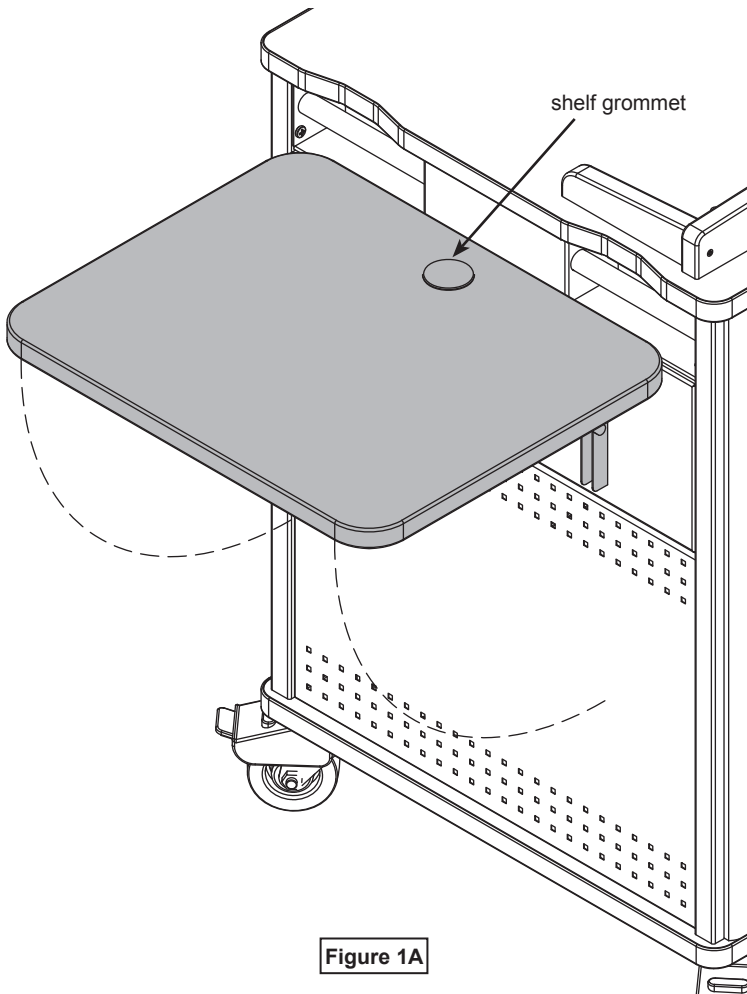

! CAUTION !
Be careful not to pinch fingers while lowering!

Note: Power & communication wiring for document cameras, laptop computers, and/or projectors placed on the flip-up shelf should be routed on top of the audience-side of the shelf. Use of the shelf grommet hole for wiring will result in pinching of the cords when the shelf is folded.

Changing rack rail position

Tools Required



Phillips Screwdriver

1. To move the rack rails from the left or right mounting positions, remove the 1/4-20 x 5/8" PHM screws attaching the rack rail brackets as shown in **Figure 2A**.
2. Move the rack rails and brackets into the new position and re-attach with the screws.

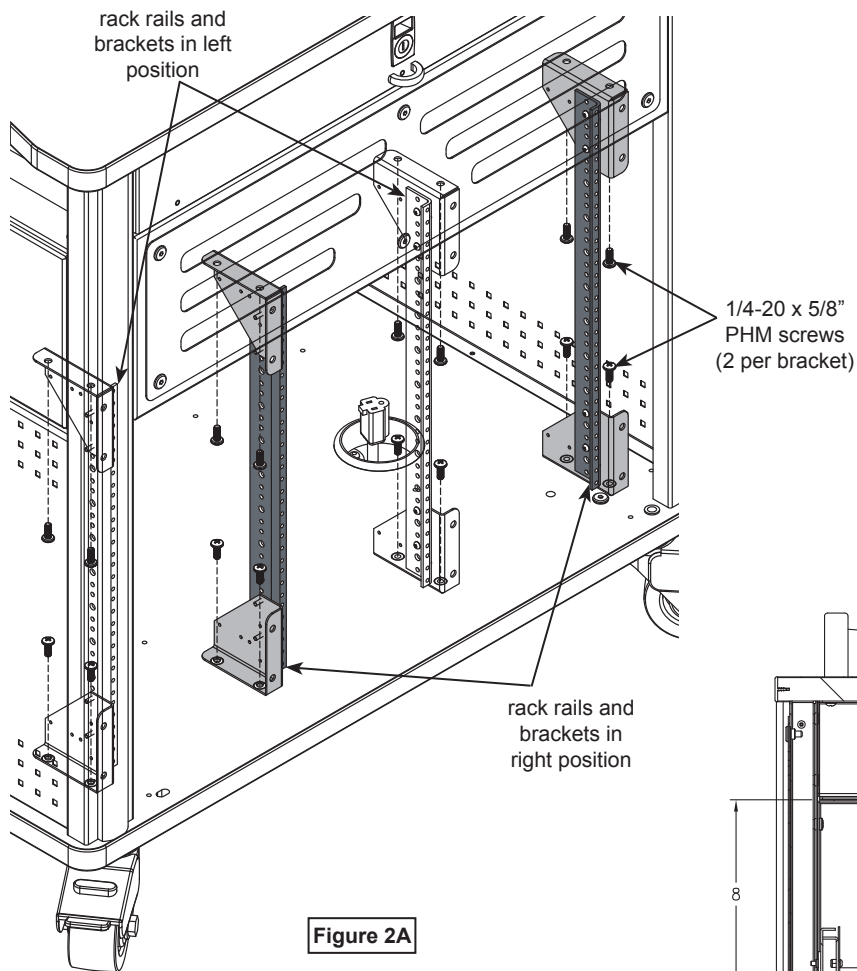

Note: The rack rails are factory-installed in the Media Manager on the side opposite the document camera drawer.

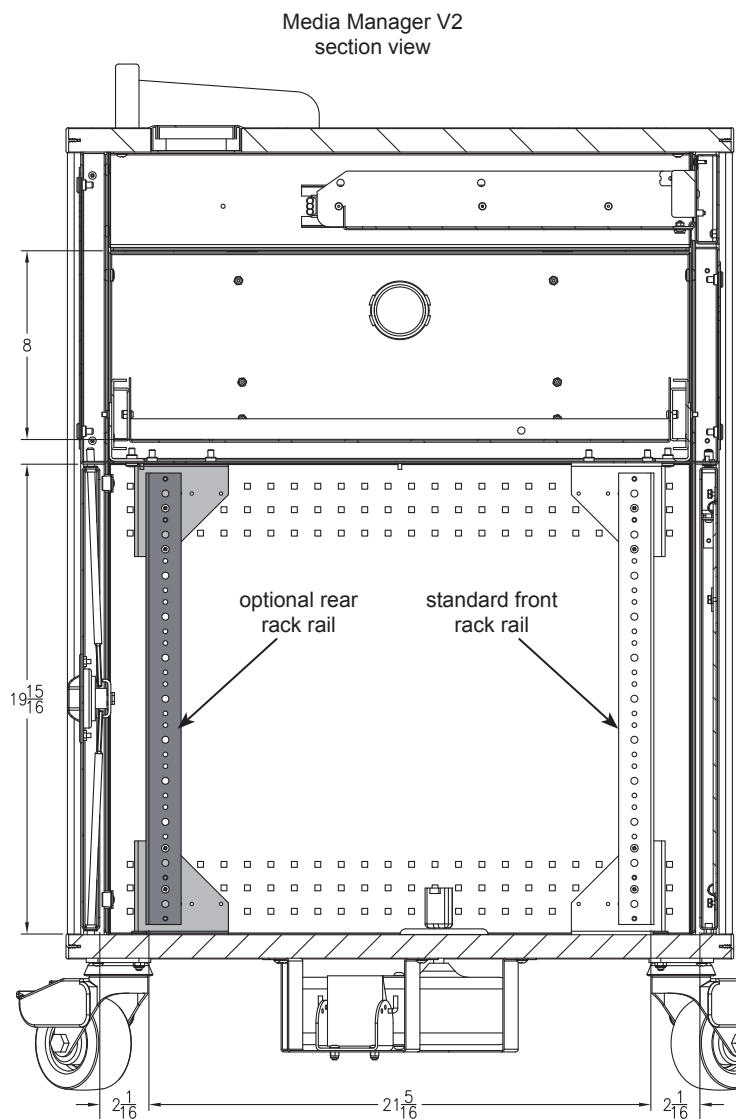

Quick-release door hinge operation

To remove door:

1. Open door wide enough to be able to access the quick-release hinge.
2. Support door with one hand.
3. With other hand, push-down on the quick-release hinge lever until the upper hinge pin clears the upper hinge pin hole. **Figure 3A.**
4. Hold the quick-release hinge lever down while tipping the top of the door away from the lectern.
5. Release the quick-release lever and lift the door up and away from lectern to remove the lower hinge pin from the lower hinge pin hole.
6. Place the door in a safe location so it does not get damaged.

To re-attach door:

1. Place the lower hinge pin into the lower hinge pin hole. **Figure 3.**
2. Push down on the quick-release hinge lever until it reaches its lowest position and hold.
3. Align the upper hinge pin to the upper hinge pin hole.
4. Release the quick-release hinge lever.
5. The door now is attached and can be opened and closed normally.

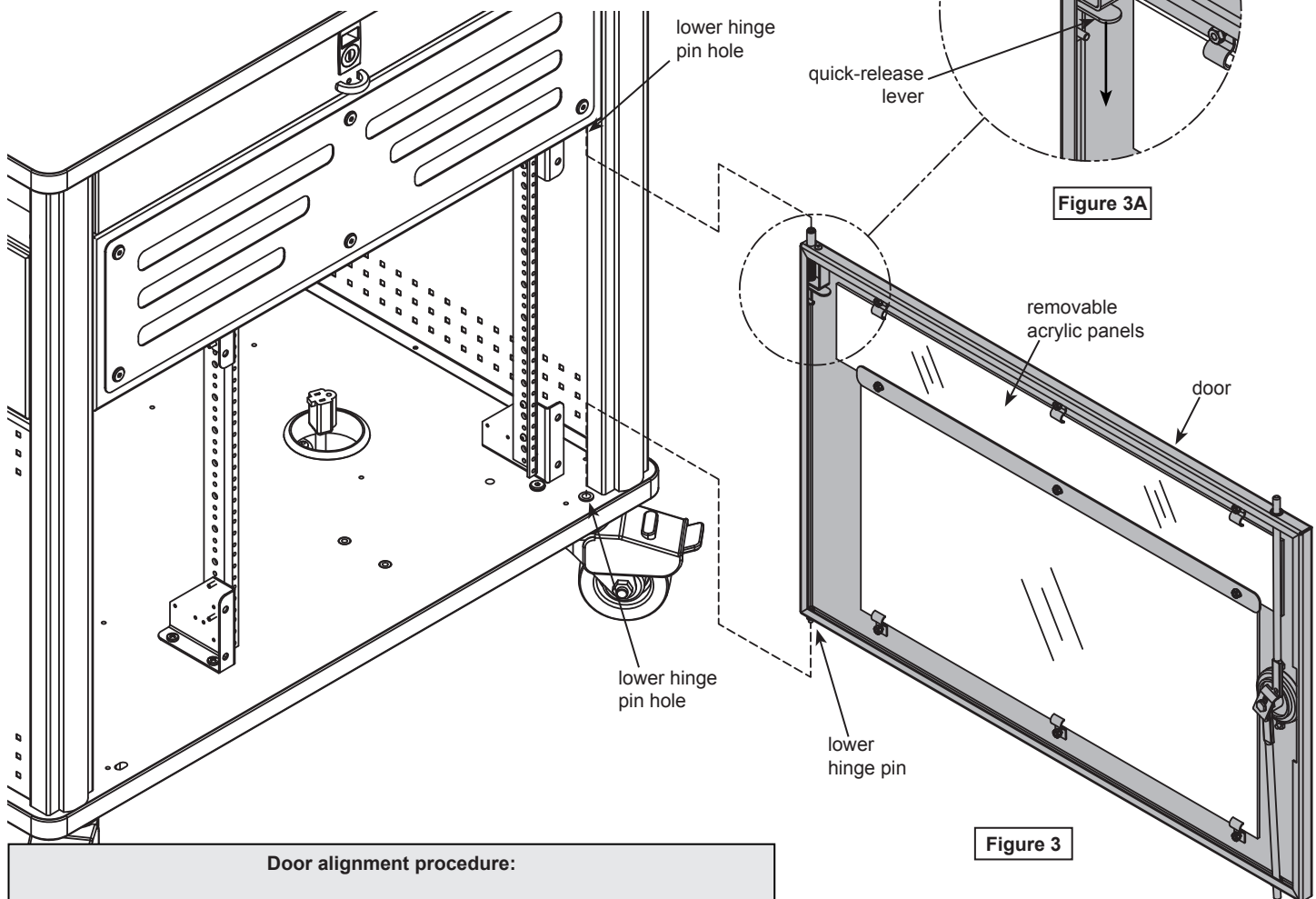

Figure 3

Door alignment procedure:

If the door appears to be misaligned, a slight adjustment can be made to the bottom hinge-side of the door. **Figure 3B.**

1. Using the quick-release lever, remove the door.
2. Set the removed door on a non-abrasive worksurface.
3. Slightly loosen the nylon locknut on the bottom corner of the door with a 3/8" or adjustable wrench and Phillips screwdriver.
4. Reposition the locknut and screw on the bottom of the door as required:
 - A. Move nut and screw away from the handle-side of the door to raise the handle-side of the door.
 - B. Move nut and screw toward the handle-side of the door to lower the handle-side of the door.
5. After adjustment, be sure the locknut is tightened securely.
6. Reinstall door and check alignment.
7. Repeat this procedure if necessary.

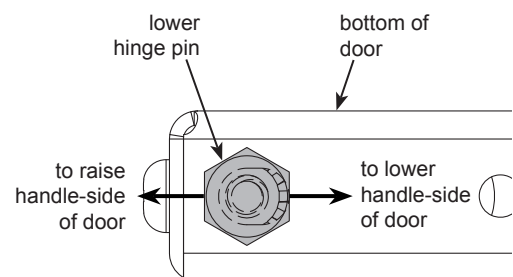
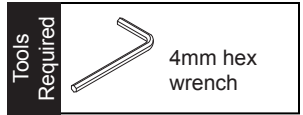

Figure 3B

Cord management



The audience-side logo panel can be removed to provide access to internal wiring.

1. Remove the (6) 1/4-20 x 15mm JC bolts and remove the panel. **Figure 4A.**
2. Cords can be accessed through the two openings behind the panel.
3. Replace the panel when wiring is complete.
4. Route cords using the grommets and cord pass-throughs provided. **Figure 4B.**

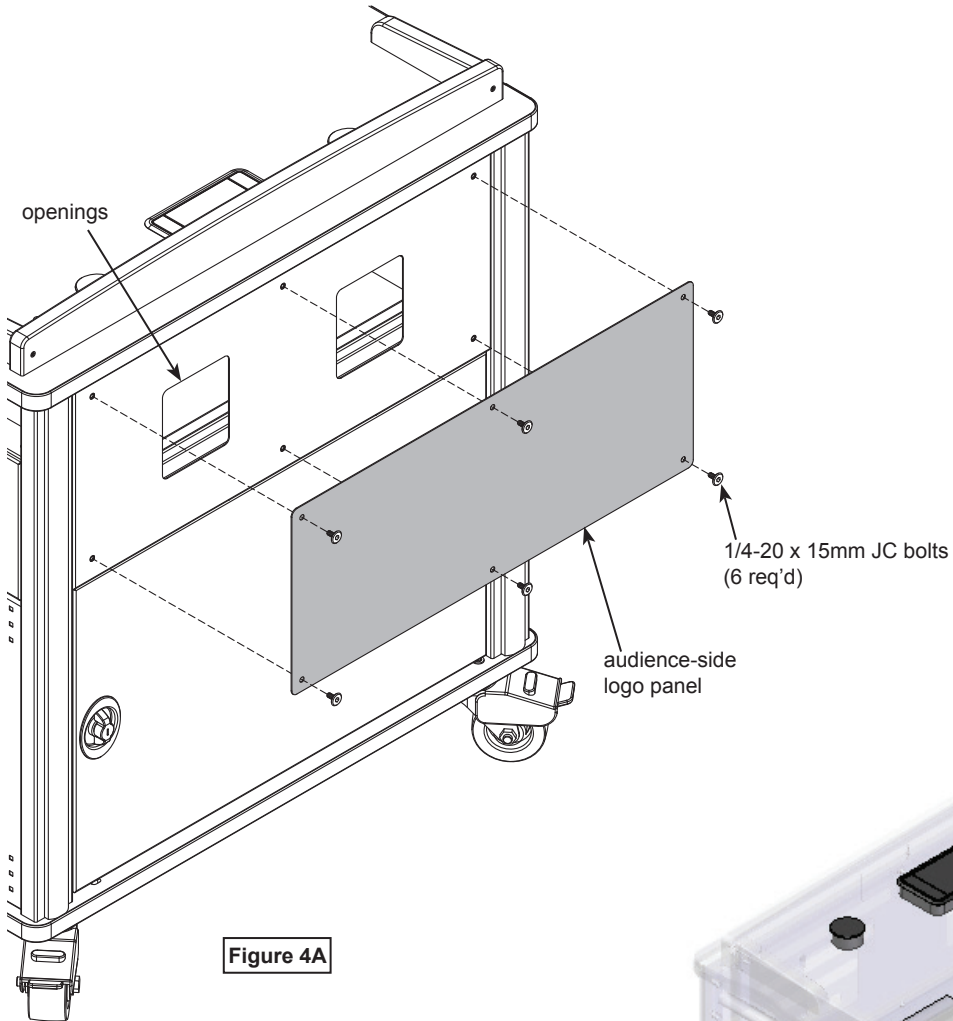

Note: Cords can be routed to different areas of the lectern using the grommets and cord pass-throughs provided.

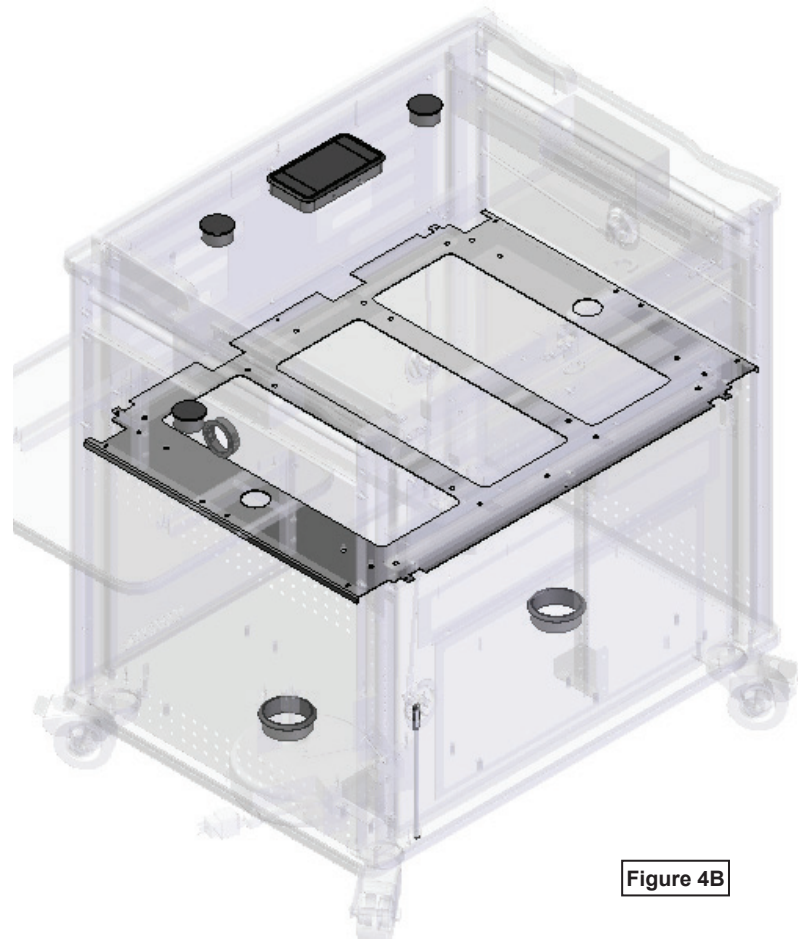

Changing cord reel position (if equipped)

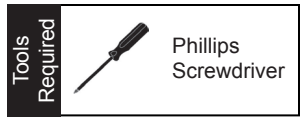

1. Remove all equipment from the lectern.
2. Lock all four casters. Carefully tip the lectern on its back-this may require 3-4 people.
3. Remove the (4) 1/4-20 x 5/8" PHM screws from the cord reel mounting bracket. See **Figure 5**.
4. Place the cord reel/bracket assembly into the new position and route the power cord through the base panel grommet.
5. Align the mounting holes and re-attach the cord reel/bracket assembly with the previously removed screws and tighten securely.
6. Carefully tip the unit back upright.

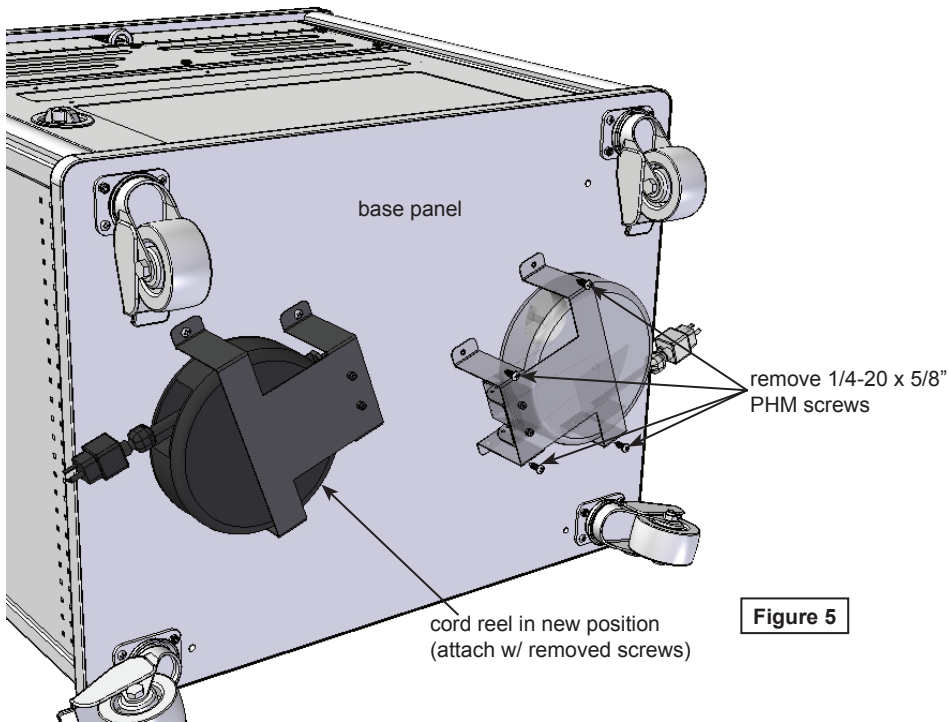

Figure 5

Floor anchoring (Toe kick versions only)



1. If your Media Manager is equipped with a toe kick, and you wish to attach it to the floor, the toe-kick will need to be detached from the lectern. To detach, remove the (4) 1/4-20 x 35mm JC bolts (one on each corner) from inside the lectern. **Figure 6**. (Save these fasteners).
2. Carefully lift the lectern off the toe kick and set aside. This will require several people.
3. Determine and locate the toe kick into its final position on the floor and mark the (4) mounting hole locations on the floor. (The toe kick mounting holes are 1/2" dia.)
4. Drill suitable holes into the floor and anchor the toe kick with appropriate fasteners.
5. Carefully lift the lectern back onto the toe kick and align the (4) mounting holes.
6. Re-attach the lectern to the toe kick with the previously removed JC bolts.
7. The access panel can be removed to access wiring below lectern.

1/4-20 x 40mm JC bolt
(access from inside lectern)
4 req'd

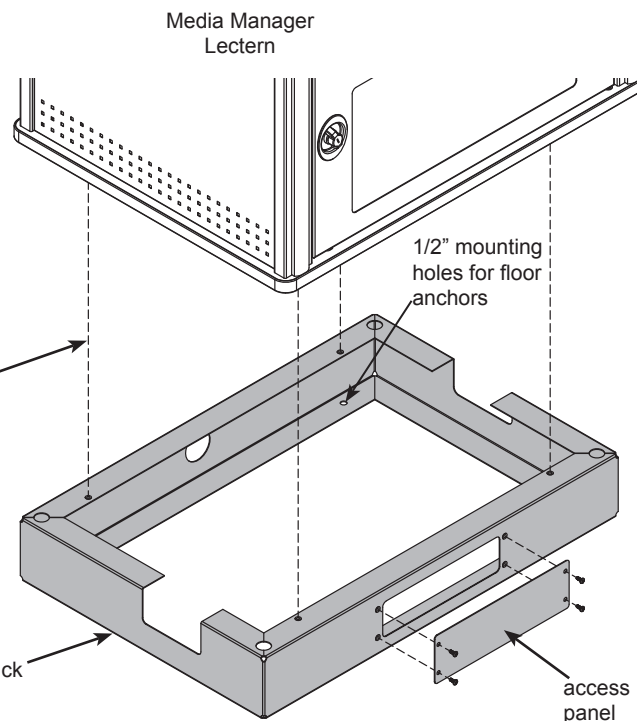

Figure 6

Note: (4) fasteners are req'd to anchor the toe kick to the floor. Due to the wide variety of flooring materials and conditions possible, anchor fasteners are not provided.

Overbridge insert panel (overbridge lecterns only)

Note: The insert panel shown (*shaded*) is not included with the lectern or overbridge. This option needs to be ordered separately to complete the overbridge.

1. To remove the insert panel, remove the (2) 1/4-20 x 35mm JC bolts with a 4mm hex wrench and lift out the panel. **Figure 7A.**
2. To make cutouts in insert panel (optional):
 - A. Identify all location(s) and sizes for controller(s) or electronics while making sure all devices fit within the maximum cutout space available in the overbridge panel. **Figure 7B, 7C.**
 - B. Locate and mark the exact cutout area(s) on the panel.
Note: Using masking tape on cut lines will minimize laminate chipping while cutting.
 - C. Carefully make the cutout(s) in the overbridge panel using a jigsaw or router.
3. Install controller(s) / electronics into panel.
4. Re-install the overbridge panel and secure with (2) 1/4-20 x 35mm JC bolts.

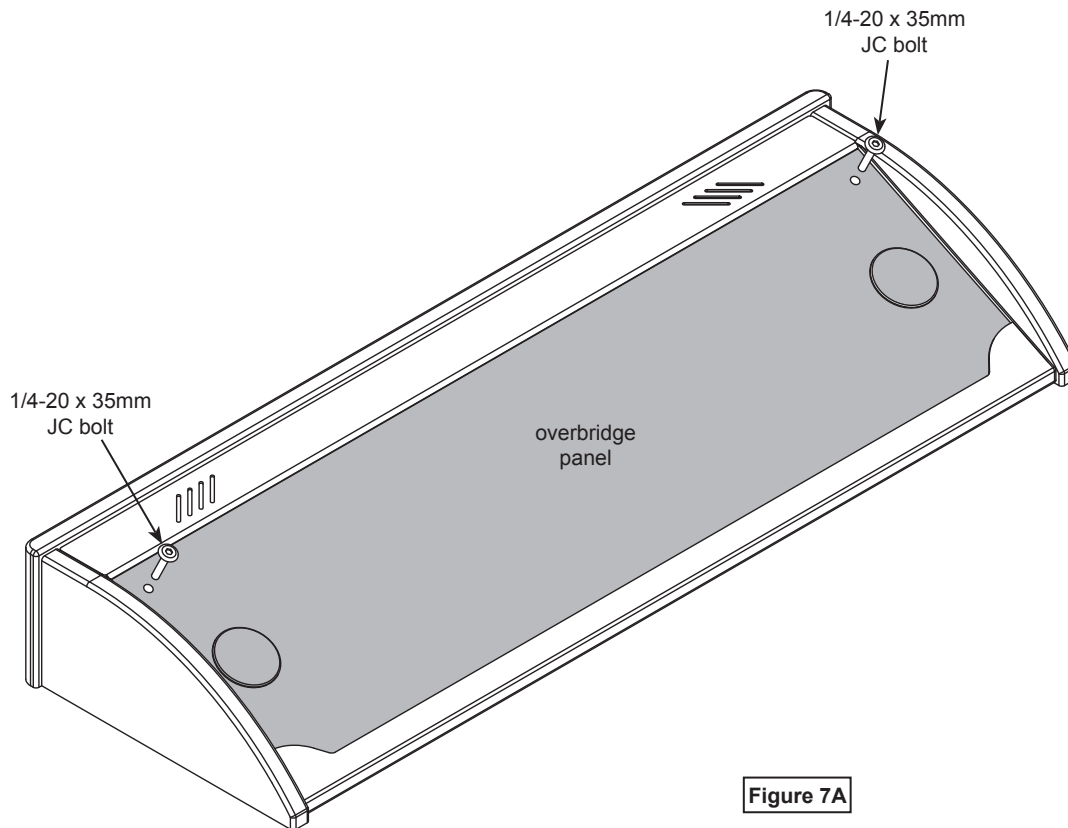
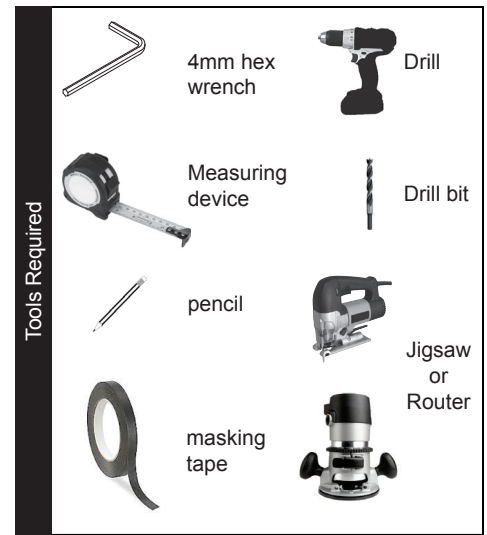

Media Manager V2 overbridge panel blank
(flat view)

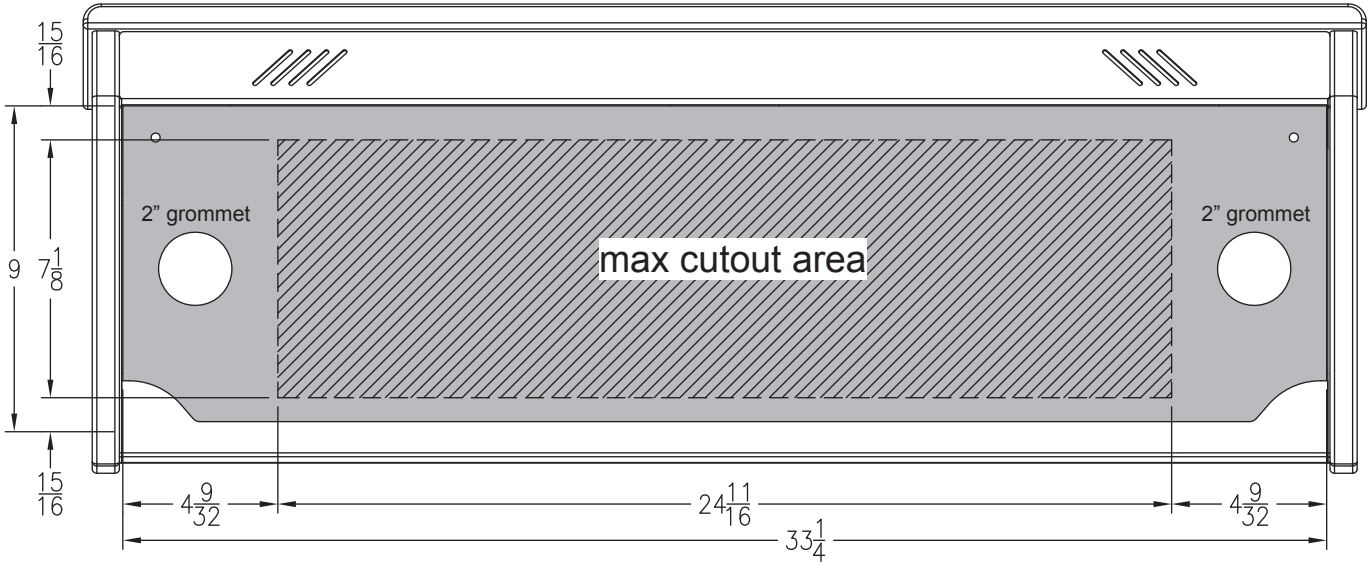
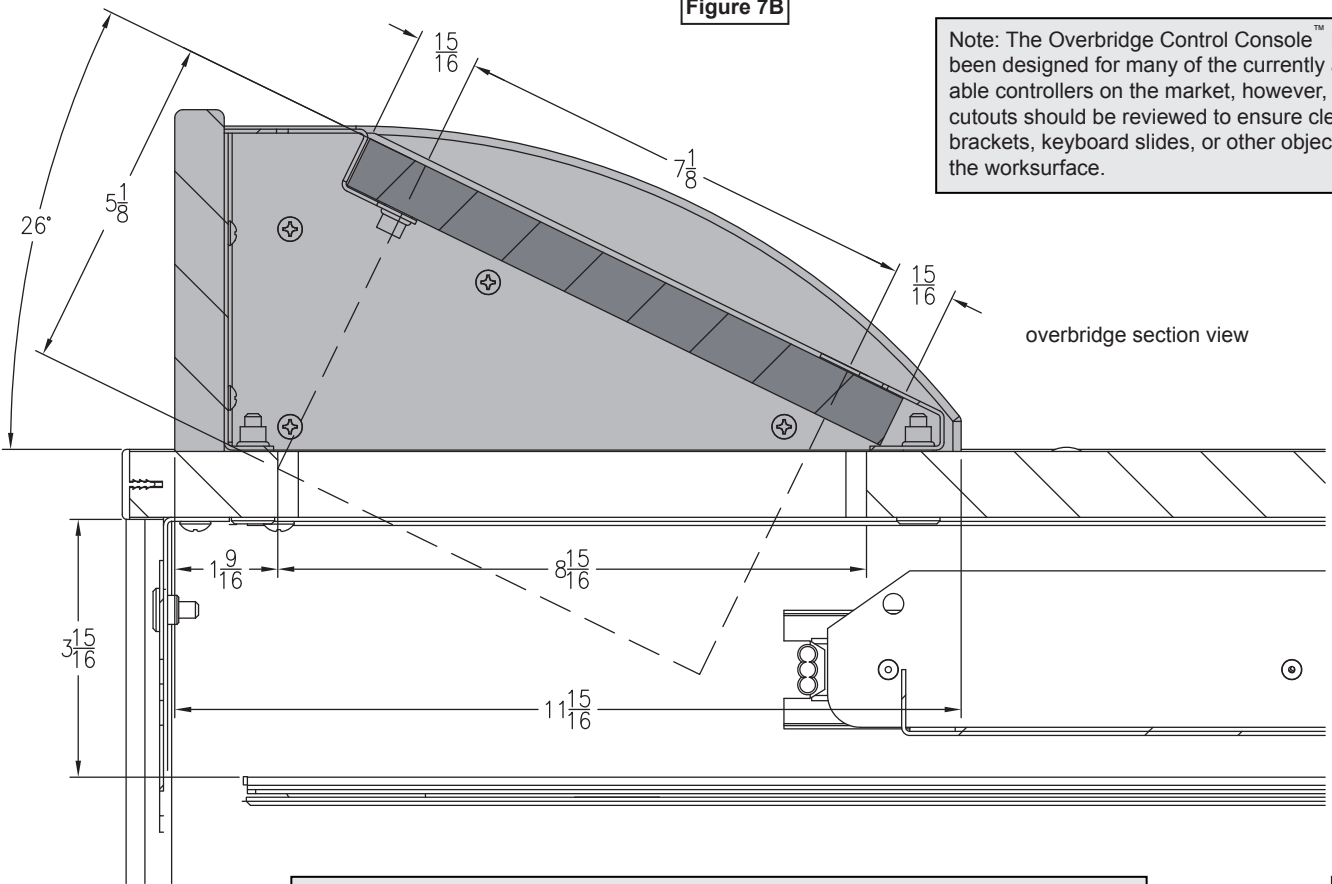

Figure 7B

Note: The Overbridge Control Console™ has been designed for many of the currently available controllers on the market, however, modified cutouts should be reviewed to ensure clearance of brackets, keyboard slides, or other objects under the worksurface.



This insert panel is horizontally symmetrical and can be easily removed, rotated 180°, and re-installed if a cutout needs to be relocated to the opposite side of the overbridge.

Figure 7C

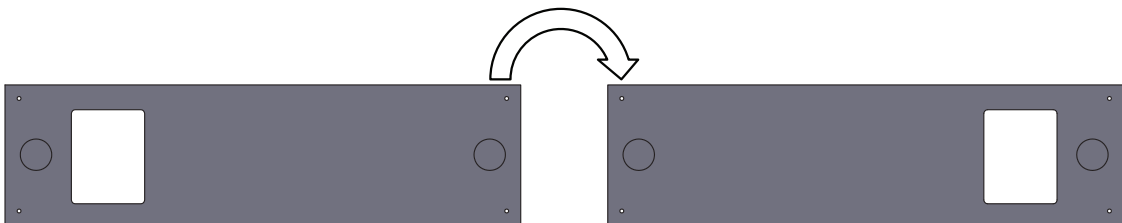

Cord reel operation

Operating Instructions:

1. **To latch cord** - Pull cord out to full length. Allow the cord to retract 1-2 feet back into the reel. Pull the cord out slowly. When a 'click' is heard, the cord will latch in place.
2. Plug into 110-125V (single phase), 3-conductor wall outlet.
3. **To release cord** - Unplug from wall outlet. Pull cord out slowly until clicking stops. The latch will release and the cord can be guided back into the reel. Do not allow the cord to fly unrestricted back into the reel.
4. Do not overload or circuit breaker (15-amp maximum) will cut off current. To restore power, remove overload, wait two minutes, then reset the circuit breaker by pressing the button on the back of the 3-prong male power plug.

Maintenance:

1. Remove dirt and grime as soon as it accumulates on the reel case by using a soft, damp cloth (a mild detergent may be used if needed), being careful not to wet the electrical plug. Never immerse any part of the unit in any solution to clean. **DO NOT** use solvents such as gasoline, turpentine, etc. to clean unit.
2. Keep cord clean to assure smoothest automatic retraction. Simply pull cord to its full length and allow to retract through a dampened rag. Pull out full length again and sprinkle cord with talcum powder.

Specifications:

15' retractable, 15-amp, 125V, 12 AWG with breaker, UL listed

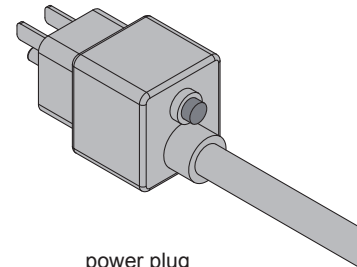
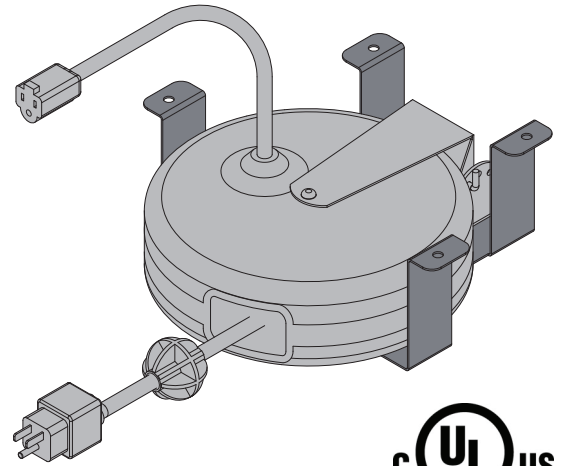

power plug

WARNING

- This cord reel is intended for general indoor use only. It is not intended to be used in potentially dangerous locations such as flammable or explosive atmospheres. The reel is not waterproof and not intended for use in potentially wet locations.
- Do not overload (15-amp maximum).

Caster operation

1. To lock the caster rotation, depress the brake lever.
2. To resume rotation, lift up on the brake lever.

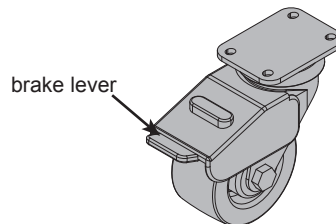

brake lever

Moving the lectern

1. Before moving the unit, unplug all power cords and retract power cord into the reel (if equipped).
2. Be sure the casters are in the unlocked position and the doors closed.
3. Move the lectern slowly and carefully.
4. Lock the casters after moving.

WARNING

ATTENTION

CAN TIP OVER RESULTING IN RISK OF INJURY, DO NOT ALLOW CHILDREN UNDER 16 TO MOVE CART. MOVE CART SLOWLY.

PEUT BASCULER, ENTRAINANT UN RISQUE DE BLESSURE, NE LAISSEZ PAS LES ENFANTS DO MOINS DE 16 POUR DEPLACER PANIER. DEPLACER PANIER LENTEMENT

ONLY ADULTS SHOULD MOVE THIS UNIT

SEULS LES ADULTES DEVRAIENT PASSER CET APPAREIL

APPLY MOVING FORCE ON NARROW DIMENSION

APPLIQUER UNE FORCE EN MOUVEMENT SUR LA DIMENSION

NEVER APPLY FORCE AT TOP ALWAYS PUSH NEAR MIDDLE

JAMAIS EMPLOYER LA FORCE EN HAUT TOUJOURS POUSSER PRES DU MILIEU

PUSH, DO NOT PULL

POUSSER, NE TIREZ PAS

Options

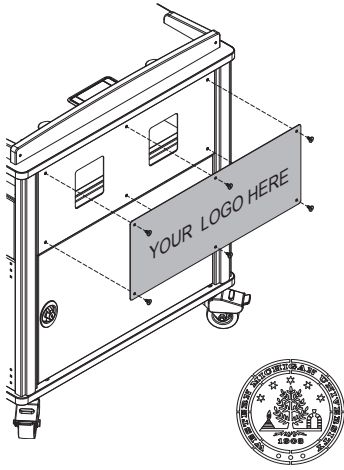

Custom-cut logo panel
(audience-side)
22½"W x 9"H
55241

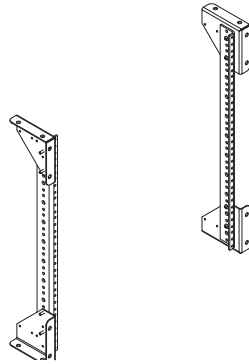

**Media Manager V2
Rear Rack Rail Kit**
11RU
55238

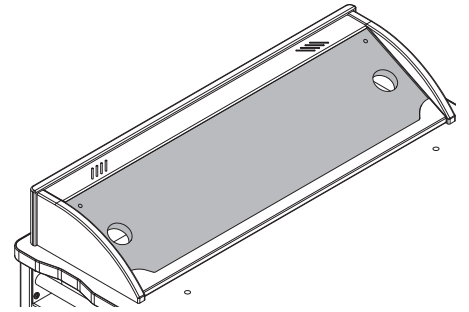

Overbridge Insert Panel
for overbridge version only-contact Spectrum
to specify cutout size(s) & position(s)-
overbridge not available separately
(includes two 2" grommets w/ covers)
96507 - blank panel
96507mod - panel with cutout(s)

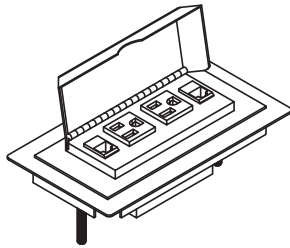

UL Listed Power/Communication Module
w/ 9' power cord, two outlets, two data jacks, &
adapter plate (standard models only)
7½"W x 3⅝"D x ¾"H
99028

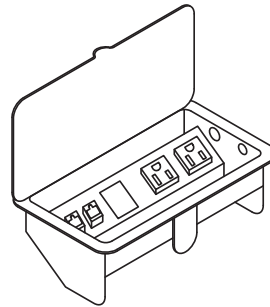

Power/Communication Module
w/ 9' power cord, two outlets, & two data jacks
7½"W x 3⅝"D (standard models only)
99003 (w/out mic jack)

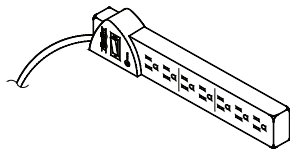

7-Outlet Power Strip, insured
w/ surge protector, and 12' cord
10"W x 2"D x 1⅝"H
99024



Replacement Key Set
55142

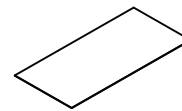

Non-Slip CPU Pad
11"W x 23"D
95518

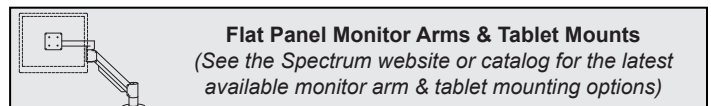

Flat Panel Monitor Arms & Tablet Mounts
(See the Spectrum website or catalog for the latest
available monitor arm & tablet mounting options)

Rack-mount accessories

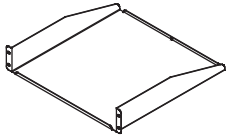

Cantilever Shelf (2RU)
 17½"W x 18"D x 3½"H
 (50 lbs max load)
 97504

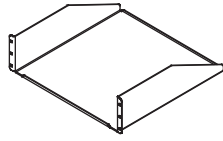

Cantilever Shelf (3RU)
 17½"W x 18"D x 5¼"H
 (80 lbs max load)
 97502

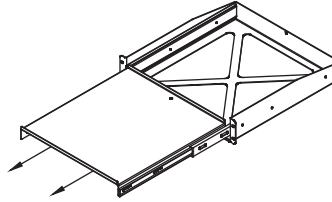

Pull-Out Shelf (2RU)
 16½"W x 17¼"D
 (50 lbs max load)
 97505

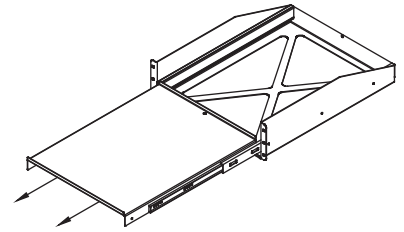

Pull-Out Shelf (3RU)
 16½"W x 21¼"D
 (80 lbs max load)
 97503

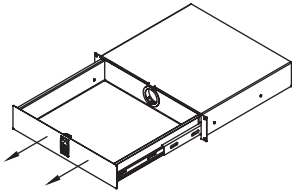

Locking Drawer (2RU)
 interior dims:
 15¾"W x 13¼"D x 2⅞"H
 (25 lbs max load)
 97514

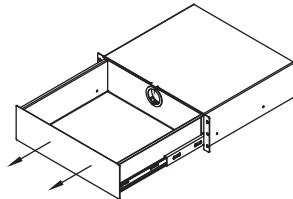

Drawer (3RU)
 interior dims:
 15¹⁵⁄₁₆"W x 14½"D x 5¼"H
 (50 lbs max load)
 97518

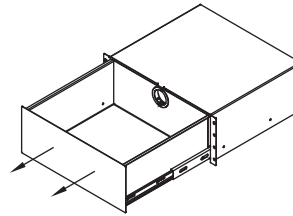

Drawer (4RU)
 interior dims:
 15¹⁵⁄₁₆"W x 14½"D x 7"H
 (50 lbs max load)
 97519

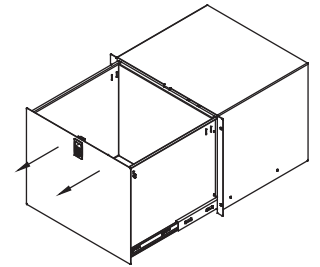

Locking File Drawer (8RU)
 w/ file holder
 interior dims:
 15¾"W x 13⅞"D x 13⅝"H
 (50 lbs max load)
 97515

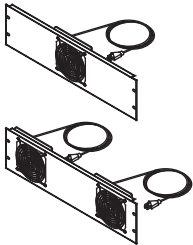

Cooling Fans (3RU)
 19"W x 2"D x 5¼"H
 Single Fan-97507
 Double Fan-97506

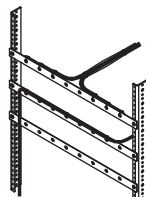

Wire Lace Kit
 3 lace straps included
 95517

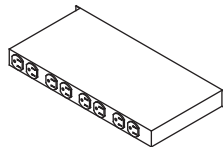

9-Outlet Power Strip (1RU)
 19"W x 9"D x 1¼"H
 99021

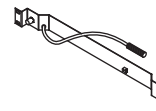

Flexible Halogen Light (1RU)
 19"W x 2"D x 1¼"H
 99033

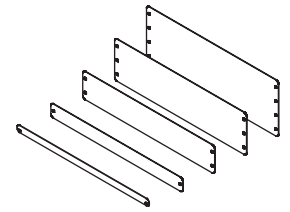

Rack-Mount Blanks
 (fills rack spaces where components are not needed)

- 97516 - (½ RU)
- 97510 - (1RU)
- 97511 - (2RU)
- 97512 - (3RU)
- 97513 - (4RU)

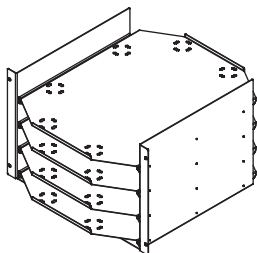

LT-4 Laptop Storage Unit (7RU)
 (stores 4 laptops horizontally)
 laptop tray dims:
 16¼"W x 20½"D x 2⅞"H
 97517

Warranty

WE WILL MAKE IT RIGHT FOR YOU!

Spectrum is committed to provide complete customer satisfaction. Each of our products are manufactured from the best materials available and each product is stringently monitored throughout the production process through our P.A.C.E. program (Product Assurance to meet Customer Expectations). Our Customer Service Help Line 1-800-235-1262 is ready to provide immediate attention to any questions, comments or concerns. We are available to answer your calls Monday through Friday from 7 am to 5 pm CST, excluding observed holidays. In addition your product comments or concerns are welcome via e-mail at: spectrum@spectrumfurniture.com.

Warranty Statement

We guarantee all Spectrum products to be free of all defects in materials and workmanship, for the original owner, for a period of ten years. Any item deemed defective by Spectrum or the original manufacturer, under normal use conditions, will be repaired or replaced at Spectrum's discretion. This warranty applies to all products manufactured and distributed by Spectrum except the products listed below.

Items that have a varying warranty include, but are not limited to, the following:

- Adjustable Crank/Electric Desk Legs (1 yr)
- Flat Panel Desk Gas Cylinders (1 yr)
- Upholstered Soft-Goods (5 yrs)
- Adjustable Height & Stacking Chair Parts – including frames, gas cylinders, wood and plastic parts, and control handles (7 yrs)
- Adjustable Height & Stacking Chair Casters (2 yrs)
- Chair Upholstery & Textiles (2 yrs of normal use of Soft Goods, Adjustable Height, Stacking, Wood and Metal Chairs)
- Chair Upholstery - Graded-In Fabrics and C.O.M (no warranty)
- Height Adjustable Columns and Lifts (1 yr)
- General Use Casters (1 yr)
- Electrical – Electri-Pak, Power Communication Modules, and special order ECA electrical items (1 yr)
- Electrical - Power Strips & Electrical Timers (1 yr)
- Electrical Surge Suppressors (lifetime)
- Electrical - Retractable Power Cords (1 yr)
- Keyboard/Mouse Trays (1 yr)
- Flat Panel Monitor Arm – General Parts (5 yrs)
- Flat Panel Monitor Arm – Gas Cylinders (2 yrs)
- CRT Monitor Arm (1 yr)

Warranty is void if product is not used for its intended purpose or subjected to an unusual application, multiple-shift use, alteration, accident, abuse or abnormal wear and tear. Representations of colors on-line and in printed materials are meant to be a close reference to the actual colors but not an exact match. Slight variations in color and texture of wood stains, powder coating, laminates, fabrics and other materials are normal in different manufacturing lots; as such these variations are not considered defects.

DESIGNED FOR INDOOR USE ONLY – Unless specifically stated in the product specifications, Spectrum's products have been designed and constructed for indoor use only. Moving or using outdoors, or on excessively rough surfaces, may cause damage to the products and will void the warranty. If an outdoor application is desired please contact us to discuss potential custom design solutions.

The warranty, as stated above, supersedes any previous warranties and is effective as of 9/1/2010

Touchboards

205 Westwood Ave, Long Branch, NJ 07740
Phone: 866-94 BOARDS (26273) / (732)-222-1511
Fax: (732)-222-7088 | E-mail: sales@touchboards.com

