

CUP AND GLASS RACK DOLLY

D2121C



CB2121C













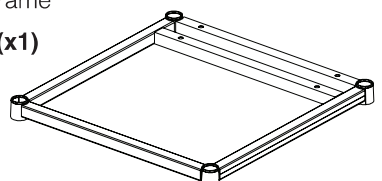

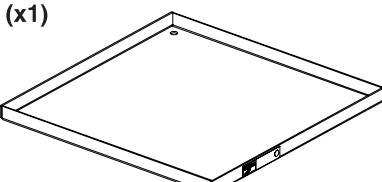





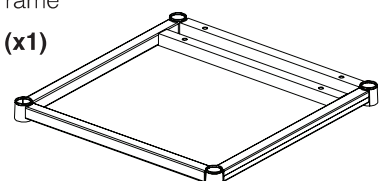

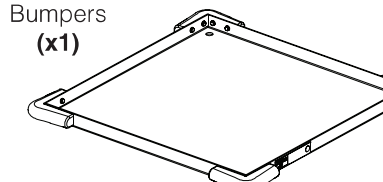





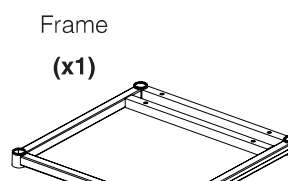
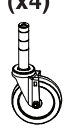
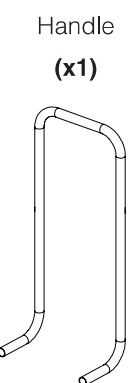

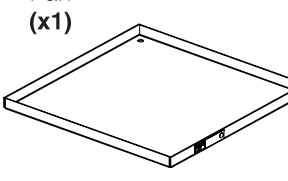



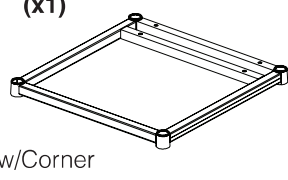

DH2121C

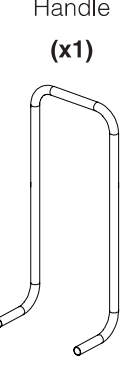

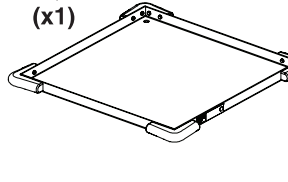
CBH2121C



COMPONENTS

<p>D2121C</p> <p>Frame (x1)</p>  <p>Post With Swivel Caster (x4)</p>  <p>Pan (x1)</p>  <p>*Screw, 5/16-18 x 1 3/4 Hex Head Cap (x4)</p>  <p>Split Sleeve Aluminum (x4)</p>  <p>Retaining Ring (x4)</p>  <p>*Nut, 5/16-18 Elastic Stop (x4)</p>  <p>Flat Head Bolt 3/8-16 x 2 1/4 (x4)</p> 	<p>CB2121C</p> <p>Frame (x1)</p>  <p>Post With Swivel Caster (x4)</p>  <p>Pan w/Corner Bumpers (x1)</p>  <p>*Screw, 5/16-18 x 1 3/4 Hex Head Cap (x4)</p>  <p>Split Sleeve Aluminum (x4)</p>  <p>Retaining Ring (x4)</p>  <p>*Nut, 5/16-18 Elastic Stop (x4)</p>  <p>Flat Head Bolt 3/8-16 x 2 1/4 (x4)</p> 
<p>DH2121C</p> <p>Frame (x1)</p>  <p>Post With Swivel Caster (x4)</p>  <p>Handle (x1)</p>  <p>Screw, 5/16-18 x 1 3/4 Hex Head Cap (x4)</p>  <p>Pan (x1)</p>  <p>Flat Head Bolt 3/8-16 x 2 1/4 (x4)</p>  <p>Clamp (x4)</p>  <p>Split Sleeve Aluminum (x4)</p>  <p>Retaining Ring (x4)</p>  <p>Nut, 5/16-18 Elastic Stop (x4)</p> 	<p>CBH2121C</p> <p>Frame (x1)</p>  <p>Post With Swivel Caster (x4)</p>  <p>Handle (x1)</p>  <p>Screw, 5/16-18 x 1 3/4 Hex Head Cap (x4)</p>  <p>Pan w/Corner Bumpers (x1)</p>  <p>Flat Head Bolt 3/8-16 x 2 1/4 (x4)</p>  <p>Clamp (x4)</p>  <p>Split Sleeve Aluminum (x4)</p>  <p>Retaining Ring (x4)</p>  <p>Nut, 5/16-18 Elastic Stop (x4)</p> 

***Note:** Items (Screw and nut) are to be used when a handle is installed on unit, if no handle will be used, disregard both items.
 Handle and Clamps are packed in separate carton.

INSTALLATION OF CB2121C / D2121C:

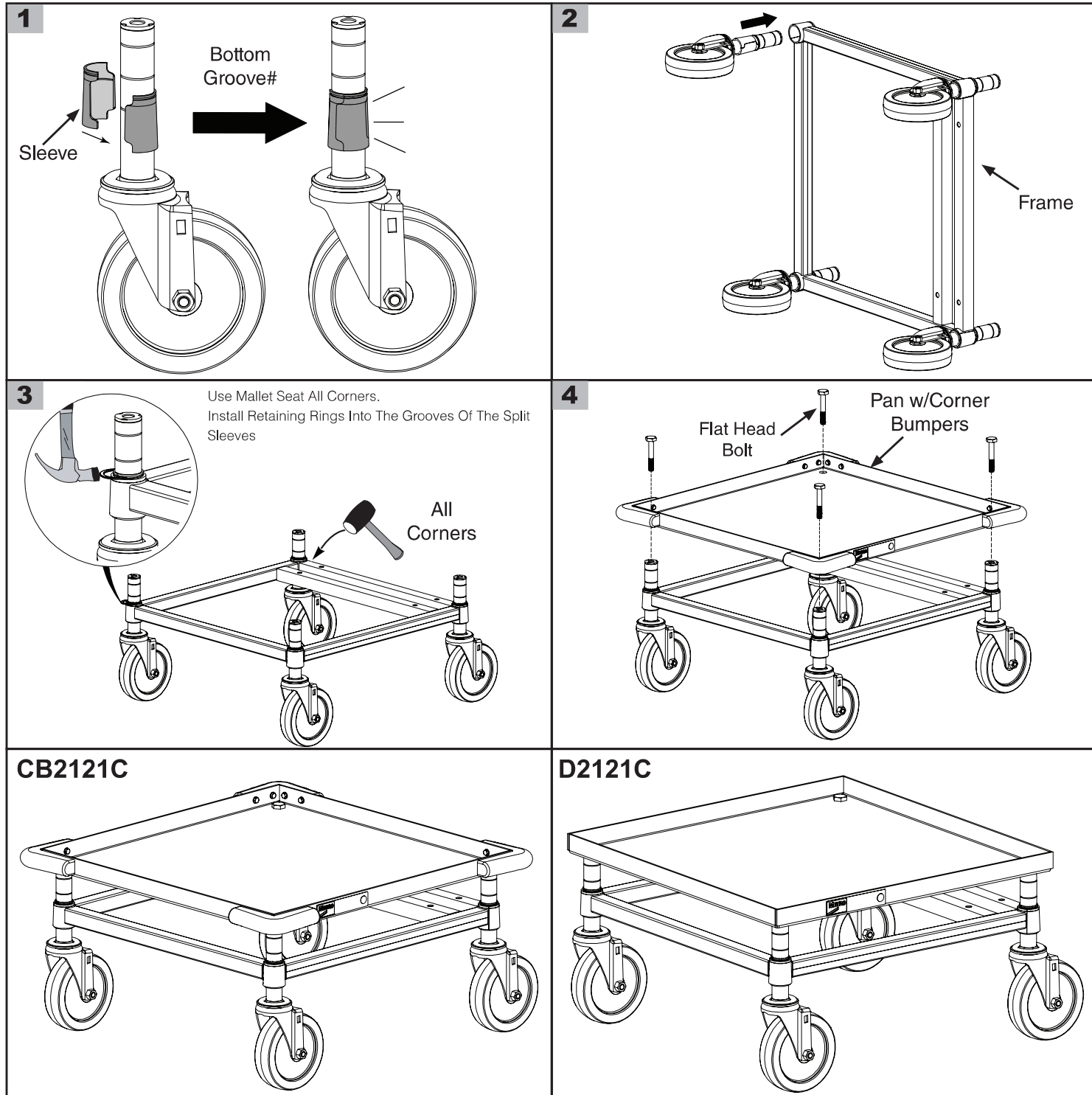

INSTALLATION OF CBH2121C / DH2121C:

<p>1</p> <p>Sleeve</p> <p>Bottom Groove#</p>	<p>2</p> <p>Frame</p>	<p>3 Use Mallet Seat All Corners. Install Retaining Rings Into The Grooves Of The Split Sleeves</p> <p>All Corners</p>
<p>4</p> <p>Handle</p> <p>Clamp</p>	<p>5 Insert The Handle So It's End Is Flush With The Inside Member.</p> <p>Screw</p>	<p>6</p> <p>Flat Head Bolt</p> <p>Pan</p>
<p>CBH2121C</p>	<p>DH2121C</p>	

THIS COMPLETES INSTRUCTIONS FOR CUP AND GLASS RACK DOLLY

* Save this document for future application, load rating and/or safety reference.

© 2019 InterMetro Industries Corporation, Wilkes-Barre, PA 18705
L01-030 REV A 01/20



We put space to work.

an Ali Group Company



The Spirit of Excellence