

# USB Cabling Guide for Interactive Devices

## INTRODUCTION

This document provides an overview of USB cabling considerations for interactive devices including interactive projectors, interactive flat panel displays, and interactive whiteboards such as MimioTeach and MimioBoard Touch.

This document will not be a primer on USB as a technology in general. The reader is referred to the USB Implementers Forum at [www.USB.org](http://www.USB.org) for extensive current and historical reference material.

## THE QUICK VERSION

1. Despite numerous websites saying the opposite, the USB standard does not state a maximum supported cable length.
2. The longest cable that your USB implementation will support depends on:
  - a. The specific implementation of the USB technology inside the two devices being connected.
  - b. The electrical nature of the cable(s) being used to connect them.
  - c. The electrical environment, including electromagnetic interference from nearby devices.
3. Use a single USB cable whenever possible. Cascading, also called daisy chaining, USB cables is one of the most common causes of troubles.
4. When your implementation mandates a longer run, it is recommended to use active USB repeaters rather than cascading multiple non-active cables or using active USB extenders.

## BACKGROUND

The USB (Universal Serial Bus) protocol was developed in the mid-1990s and is maintained by the USB Implementers Forum. The major variants are:

- USB 1.X: Maximum payload data rate of 12 Mbit/s on Type-A and Type-B connectors only
- USB 2.X: Maximum payload data rate of 280 Mbit/s and added Mini-A, Mini-B, and Micro-USB connectors
- USB 3.X: Maximum payload data rate of 4 Gbit/s over the same connectors

As with almost every data communication standard, USB is an “interface standard” that defines voltage, current, pinouts, maximum supported data rate, data structures, and protocols at the connector. This is sometimes a source of consternation when users ask “What length cable can the standard support?” The standard does not address cable lengths or types, the standard only describes signals at the connector.

It is worth noting that even if a device is using USB 3.X, for example, that does not necessarily indicate the device is actually sending data at that rate. A typical interactive projector or flat panel data rate would be under 1 Mbit/s no matter what version of USB it uses.

## CABLING CONSIDERATIONS

The main challenge when connecting data devices, including those communicating over USB, is to do no harm. That means faithfully delivering the signals in each direction. Many Internet sources state that USB supports cables up to 5m (roughly 16'). However, this 5m “maximum” is actually just a rule of thumb—the USB standard does not discuss cable lengths.

Further, this 5m rule of thumb only applies to USB 1.X and USB 2.X installations. The “rule” for USB 3.x is 3m, a bit over 9', because of USB 3.X's higher data rate.

# USB Cabling Guide for Interactive Devices

## Cable Quality

The ability of a cable to “do no harm” is affected by:

- **Wire gauge:** Higher diameter wires have lower resistance, and thus reduce the signal less as it travels from end to end.
- **Internal insulation:** Data cables have multiple individual wires, generally referred to as conductors, inside the outer insulation as shown below. When data signals are sent through the conductors, the data can “crosstalk” and corrupt the signals. The thickness and nature of the insulation on each conductor affects the amount of crosstalk.



- **Shielding:** The foil that wraps around the data wires provides a degree of protection from external electrical interference. Better shielding provides greater reduction of external interference.
- **Connectors:** The quality of the connectors at each end of the cable can also have an effect on signal quality. If the connector is not manufactured to the required size and shape, it may not fit well and may even come loose over time—a particularly serious problem when the connectors are plugged into a projector mounted 8' above the floor.
- **Environmental conditions:** Some lighting dimmers use silicon controlled rectifiers (SCRs) that can generate considerable electronic interference. Additional interference can come from other data cables run nearby, motors in elevators, or other devices—even microwave ovens.

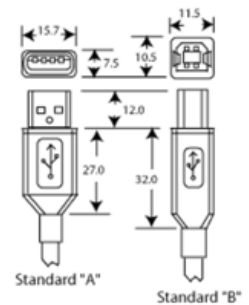

## Physical Length Is Not the Same as Electrical Length

That 5m rule of thumb also assumes a single cable. When multiple cables are cascaded in a daisy chain, the resulting electrical length can be longer than the physical length. The diagram below shows some possible results. Simply put, the 5m rule means one cable not exceeding 5m from end to end.

### The Surprising Math of a USB “Daisy Chain”

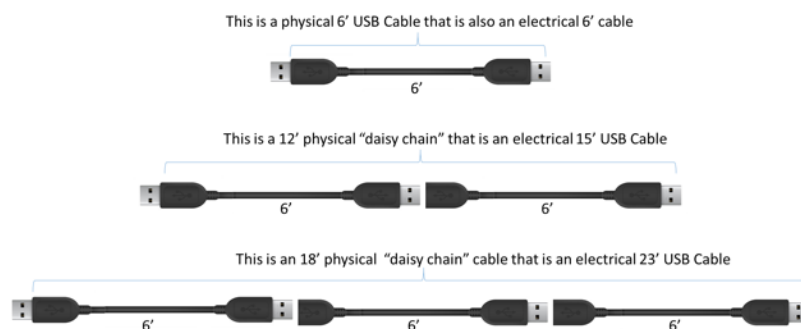

## USB Cabling Guide for Interactive Devices

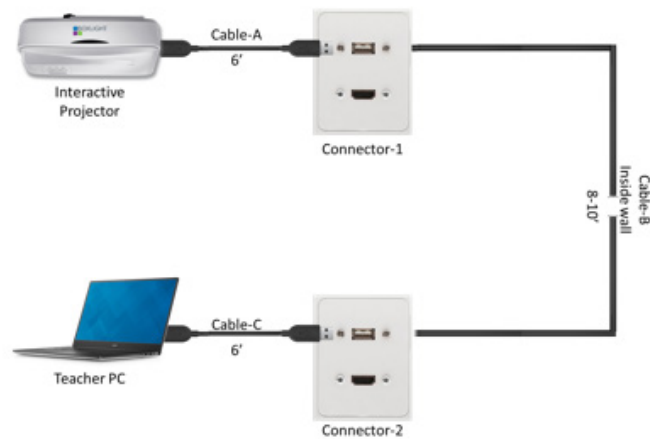

A common area where problems occur is when an interactive display device, usually a projector or flat panel, is mounted on the wall and cables run through the wall to connect to the teacher PC. Total cable runs in excess of 30', sometimes with multiple cables daisy chained, have been observed—well beyond any reasonable expectation of “do no harm” successful data connections. The example below shows approximately 22' of physical length that could easily be 25–30' of electrical length.

### LONGER CABLE RUNS

There are instances where longer runs are essential—the 5m theoretical maximum just will not suffice. In these situations, the solution is an active USB extender which converts the distance-limited USB format connection to one that can run much longer distances over Cat 5 or Cat 6 network cables.

Numerous manufacturers offer active USB extenders. Some are described as an inline cable extender, which draws power from the PC to which it is connected. Others are box type, which are sometimes powered separately.



The extremely wide range of manufacturers and models combined with the variables in each school’s implementation makes it impractical to certify or recommend a particular model. As with many products, “you get what you pay for” is usually true. It is important to review the rated distance for any candidate device and compare it to the cable length needed in the installation.

When extending USB for interactive displays, it is recommended to use an extender rated for USB 1.1 or higher or for USB 2.x. A USB 3.x extender is not necessary for this application.

It is essential to be certain the extender is powered, or else it will not actually be active. Verify that the extender is connected to a powered USB port, or hub, or has its own power supply.

# USB Cabling Guide for Interactive Devices

## *Active Extender Candidates*

Boxlight does not recommend an extender other than our own the P8USB-BOOSTER.

Boxlight users have had positive experiences with the CablesToGo “USB 1.1 Over Cat5 Superbooster Extender Dongle Kit for Interactive Whiteboards” (Part # 29338 ), Monoprice “USB Extender” (Product ID: 6042), StarTech USB2001EXT2P, and the TrippLite B203 series.

## *The Weasel Words and Troubleshooting*

Sometimes even the best of planning, the best of products, and the best installation produce a system where the interactive device does not seem to operate properly when connected to the teacher PC.

All Boxlight interactive displays have been tested and verified to operate properly when directly connected to the teacher PC via a single high-quality cable of 5m or less. Boxlight is not a manufacturer of networking or cable extender products, and thus cannot actively support them within interactive systems.

In a system where daisy chained cables, cable extenders, or cables longer than 5m are used, the following diagnostic process is recommended:

- Temporarily move the PC near enough to the interactive device to make a direct connection using a single cable of 5m or less.
- If this temporary configuration operates properly, then the PC and interactive device are working as designed and the problem can reasonably be understood to be elsewhere.

Having verified the interactive device and the PC are operating properly, the problem has now been determined to be the cabling. To determine the specific cause, first verify that the total cable length in the implementation is less than 5m. If longer than 5m, either reduce the cable length or insert a USB cable extender. If a USB cable extender is included, please contact the provider of the extender for support.