

MIPRO®

User Guide

Portability • Simplicity • Flexibility

MA-303 Series

Personal Wireless Public Address System



MIPRO®
MICROPHONE PROFESSIONALS

MIPRO Electronics Co., Ltd

Headquarters : 814 Pei-Kang Road, Chiayi, 60096, Taiwan
Tel : +886.5.238.0809 Fax : +886.5.238.0803
www.mipro.com.tw mipro@mipro.com.tw



2 CE492A

All rights reserved. Do not copy or forward without prior approvals MIPRO.
Specifications and design subject to change without notice. MN 014/05

! IMPORTANT SAFETY INSTRUCTIONS !

1. Read these instructions.
2. Keep these instructions.
3. Heed all warnings.
4. Follow all instructions.
5. Do not use this apparatus near water.
6. Clean only with a dry cloth.
7. Do not block any ventilation openings. Install in accordance with the manufacturer's instructions.
8. Do not install near any heat sources such as radiators, heat registers, stoves, or other apparatus (including amplifiers) that produce heat.
9. Do not defeat the safety purpose of the polarised or ground plug: A polarised plug has two blades with one wider than the other. The wide blade is provided for your safety. When the provided plug does not fit into your outlet, consult an electrician for replacement of the obsolete outlet.
10. Protect the power cord from being walked on or pinched particularly at plug, convenience receptacles, and the point where they exit from the apparatus.
11. Only use attachments/accessories specified by the manufacturer.
12. Use only with a cart, stand, tripod, bracket, or table specified by the manufacturer, or sold with the apparatus. When a cart is used, use caution when moving the cart/apparatus combination to avoid injury from tip-over.
13. Unplug this apparatus during lightning storms or when unused for long periods of time.
14. Refer all servicing to qualified service personnel. Servicing is required when the apparatus has been damaged in any way, such as power-supply cord or plug is damaged, liquid has been spilled or objects have fallen into the apparatus, the apparatus has been exposed to rain or moisture, does not operate normally, or has been dropped.
15. To reduce the risk of fire or electric shock, do not expose this apparatus to rain or moisture.
16. Apparatus should not be exposed to dripping or splashing and no objects filled with liquids, should be placed on the apparatus.
17. Use only with the battery which specified by manufacturer.
18. The power supply cord set is to be the main disconnected device.



WARNING

1. **FOR OUTDOOR USE:**
To reduce the risk of fire or electric shock, do not expose this apparatus to rain or moisture.
2. **UNDER WET LOCATION:**
Apparatus should not be exposed to dripping or splashing and no objects filled with liquids, such as vases should be placed on the apparatus.
3. **SERVICE INSTRUCTIONS:**
CAUTION - These servicing instructions are for use by qualified service personnel only. To reduce the risk of electric shock, do not perform any servicing other than that contained in the operating instructions unless you are qualified to do so.

	This symbol indicates that dangerous voltage constituting a risk of electric shock is present within this unit.
	This symbol indicates that there are important operating and maintenance instructions in the literature accompanying this unit.

FC & IC - ID

THIS DEVICE COMPLIES WITH PART15 OF THE FCC RULES AND RSS-123 ISSUE2 OF CANADA. OPERATION IS SUBJECT TO THE FOLLOWING TWO CONDITIONS:

- (1) This device may not cause interference.
- (2) This device must accept any interference, including interference that may cause undesired operation of the device. This equipment complies with FCC RF radiation exposure limits set forth for an uncontrolled environment.

"This product can only be used at the area that the altitude is lower than 2000m for safety purpose."

"This product can be used in non-tropical locations only for safety purpose."

Disposal Dispose of any unusable devices or batteries responsibly and in accordance with any applicable regulations.



2005-08-13

Disposing of used batteries with domestic waste is to be avoided!
Batteries / NiCad cells often contain heavy metals such as cadmium(Cd), mercury(Hg) and lead(Pb) that makes them unsuitable for disposal with domestic waste. You may return spent batteries/ accumulators free of charge to recycling centres or anywhere else batteries/accumulators are sold.

By doing so, you contribute to the conservation of our environment!

CONTENTS

- 1 Accessories
- 2 Controls and Indicators
- 4 Control Panel and Displays
- 6 USB Display Screen
- 12 USB Remote Controls and Indicators
- 13 Replacing USB Remote Battery
- 14 Replacing the Rechargeable Battery
- 17 System Channel Set-Up
- 20 ACT Synchronization (sync) Between Receiver and Transmitter Channels
- 21 Operating Instructions
- 23 Pairing Bluetooth Music Receiver
- 25 Connection to External Audio Sources
- 26 USB Drive Operation
- 27 Six Available Configurations
- 30 Troubleshooting-Portable Public Address
- 31 Troubleshooting-Wireless Microphone Systems
- 34 Rechargeable Battery Guide
- 35 Optional MA-303 Accessories
- 36 MIPRO Wireless Microphone Systems for MA-303

ACCESSORIES

The following accessories are included:

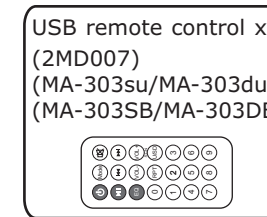
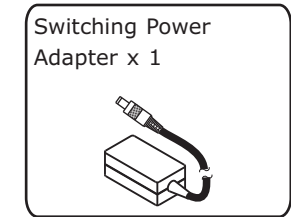
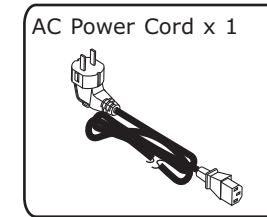
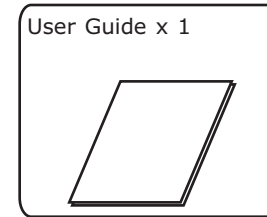

ACCESSORIES

The following accessories are not included:



CONTROLS AND INDICATORS

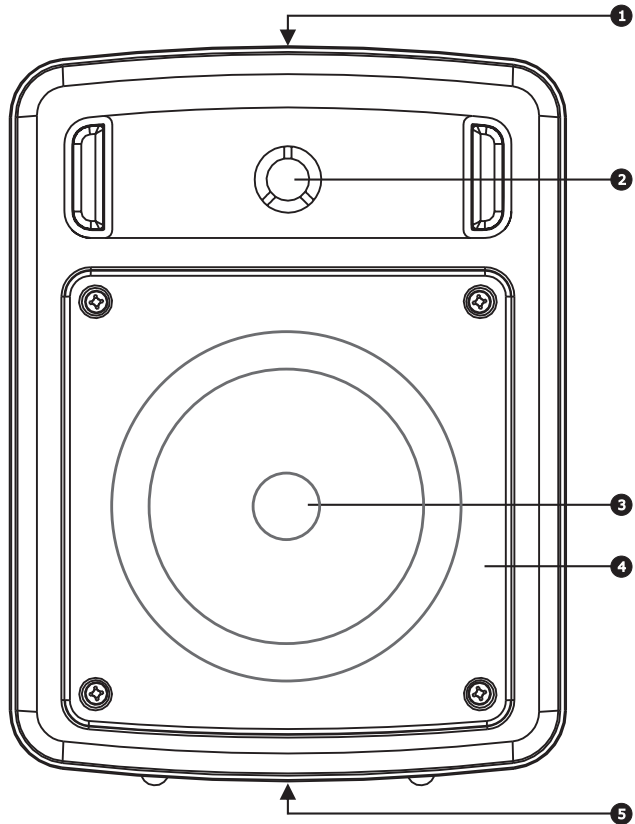

- ❶ **Fixed Carry Handle**
- ❷ **Treble Speaker:** 1-inch.
- ❸ **Bass Speaker:** 5-inch full range high efficiency.
- ❹ **Speaker Grille:** To protect the loudspeakers.
- ❺ **Mic Stand Adapter:** For mounting onto a microphone stand (15.8mm/ 3/8") or a wall mounting rack MS-90.

CONTROLS AND INDICATORS

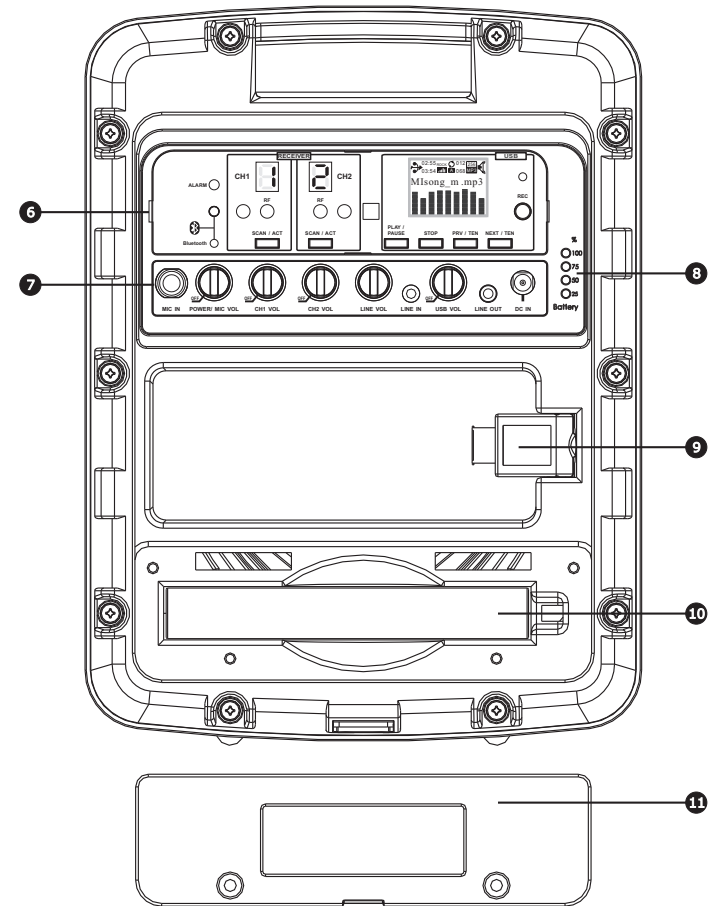

Model Shown: MA-303DB

- ❻ **Display Panels and Screens**
- ❼ **Power/Volume Control Panel**
- ❽ **Battery Meter:** Displays current & charging battery level.
Blinking (charging in progress); Illuminated (battery is fully charged)
- ❾ **USB 2.0 Port**
- ❿ **Rechargeable Battery & Compartment**
- ⓫ **Battery Cover:** Protects the rechargeable battery.

CONTROL PANEL AND DISPLAYS

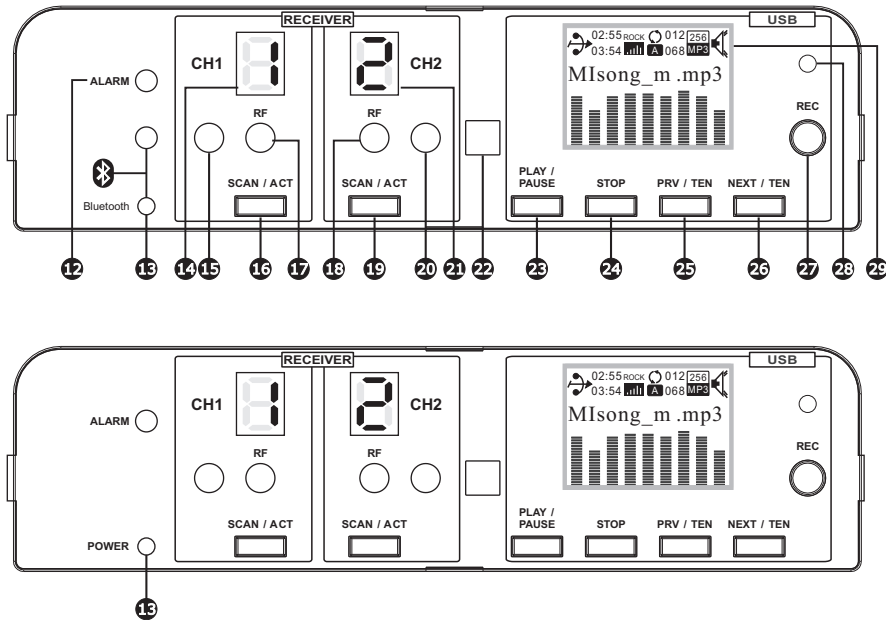

- 12 **Alarm Siren Button:** Provide warning of approaching or presence of threats or situations requiring immediate attention.
- 13 **Bluetooth Power Button & Indicator:** The built-in Bluetooth music receiver lets you connect a Bluetooth-enabled wireless device such as an iPod, iPhone, iPad or other smart phones, tablets, media players and play music wirelessly through this portable PA system.
Power indicator: Glows red when master power is on and ready for operation.
- 14 **CH1 Channel Screen**
- 15 **CH1 Sync Port:** Uploads infrared signal to transmitter.
- 16 **SCAN / ACT CH1:** Scans for an interference-free frequency & Synchronizes the receiver and transmitter frequencies.
- 17 **CH1 RF Indicator:** Glows green indicates a RF link from transmitter to receiver.
- 18 **CH2 RF Indicator:** Glows green indicates a RF link from transmitter to receiver.
- 19 **SCAN / ACT CH2:** Scans for an interference-free frequency & Synchronizes the receiver and transmitter frequencies.

- 20 **CH2 Sync Port:** Uploads infrared signal to transmitter.
- 21 **CH2 Channel Screen**
- 22 **USB Remote Port**
- 23 **PLAY / PAUSE Button:** Plays or pauses the track.
- 24 **STOP Button:** Stops the track.
- 25 **PRV / TEN Button:** Skip to previous track & fast rewind 10 tracks.
- 26 **NEXT / TEN Button:** Skips to next track & fast forward 10 tracks.
- 27 **REC Button**
- 28 **REC Indicator**
- 29 **USB Display Screen**

Power/Volume Control Panel

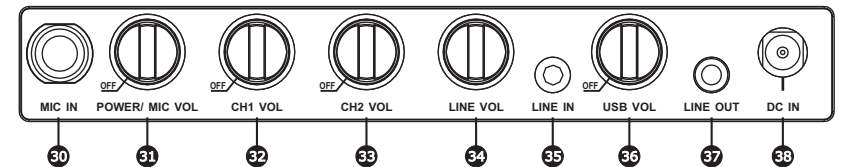

- 30 **MIC IN:** Standard 6.3mm (1/4") microphone level input jack. Accepts a MIPRO MM-107 (not included) wired dynamic microphone.
- 31 **POWER / MIC VOL:** Master power on/off and microphone volume.
- 32 **CH1 VOL:** Powers receiver on/off and wireless CH1 volume.
- 33 **CH2 VOL:** Powers receiver on/off and wireless CH2 volume.
- 34 **LINE VOL:** Controls the volume level of line-input.
- 35 **LINE IN:** 3.5mm (1/8") mini-jack input. Accepts external CD/MP3/iPod/cassette/VCR/DVD player, musical instruments, computer sound card or other line-level signal source.
- 36 **USB VOL:** Powers USB on/off and USB player volume.
- 37 **LINE OUT:** 3.5mm (1/8") mini-jack output. Connects to another powered PA system or external recordings.
- 38 **DC IN:** Connects the supplied switching power adaptor to recharge the battery or to supply power to the system.

USB DISPLAY SCREEN

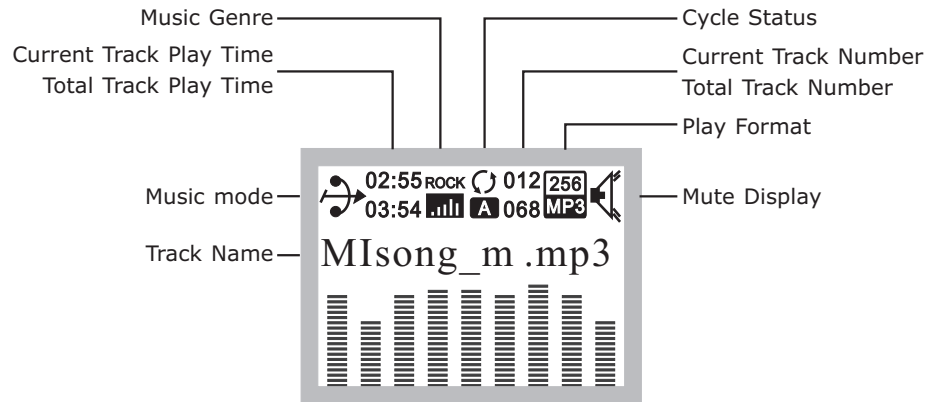

Press **PLAY/PAUSE** button to pause track

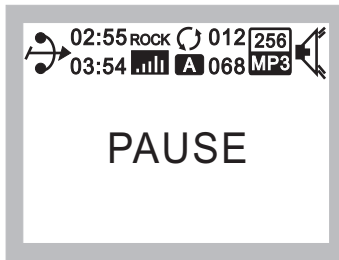

USB is not inserted

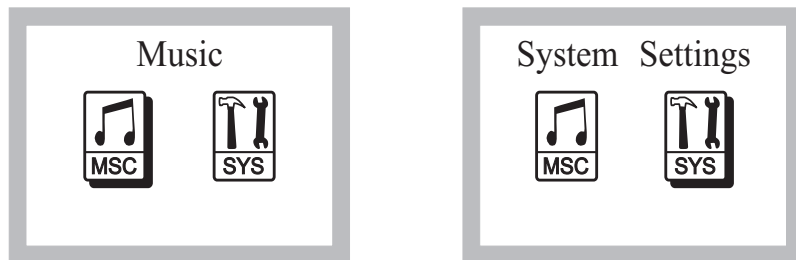

Panel Operational Instructions

- During track playing, press & hold PLAY/PAUSE button to enter music parameter selection for changes. Press PRV/TEN or NEXT/TEN to highlight selection, Press PLAY/PAUSE to enter this parameter. Press PRV/TEN or NEXT/TEN to locate the desired parameter, Press PLAY/PAUSE to confirm change and save.

Remote Operational Instructions

- During track playing, press Mode to enter music parameter selection for change. Press ◀◀ or ▶▶ to highlight selection. Press Mode to confirm.

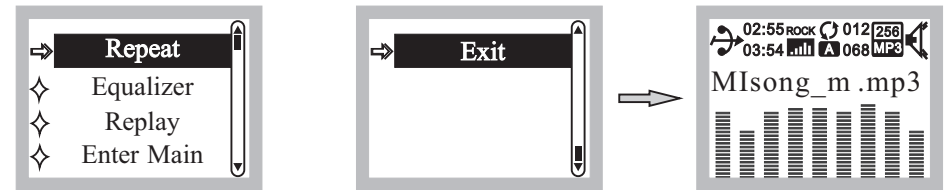

Continuous Mode: Press PRV/TEN or NEXT/TEN.

- Repeat All: All Continuous "A"。
- Repeat Folder: Folder Continuous "D"。
- Repeat One: Single Track Continuous "1"。
- Random: Random Track Play "R"。

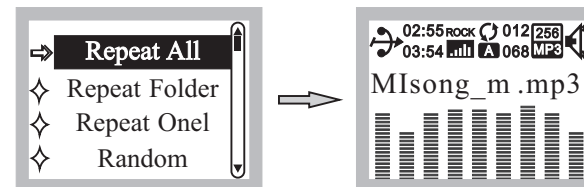

Equalizer: EQ Mode

- Press PRV/TEN or NEXT/ TEN to enter.
- Press PLAY/PAUSE to confirm.

- Natural: Normal "NOR" 
- Pop: Popular "POP" 
- Rock: Rock "ROCK" 
- Jazz: Jazz "JAZZ" 
- Classic: Classical "CLAS" 
- Soft: Soft "SOFT" 
- DBB: Deep Bass "DBB" 

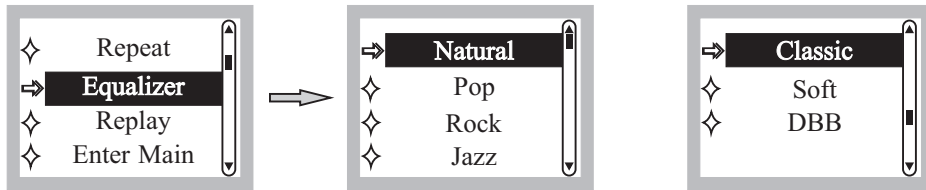

Replay Mode

- Reply A- / -B mode.
- In Replay mode, press NEXT/ TEN to move A- to -B to A-B selection, Press PLAY/PAUSE to start and press STOP to stop Reply.

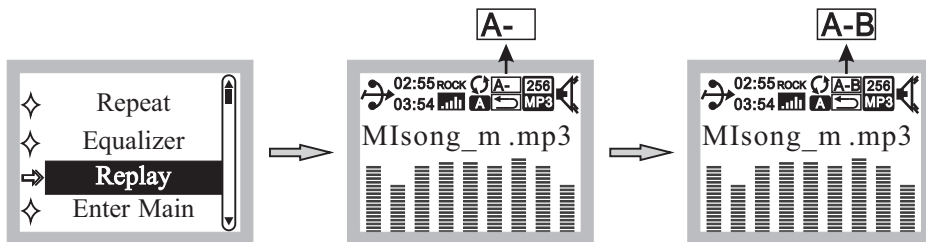

Music Mode: Press PRV/TEN or NEXT/ TEN to select track number.

- Music: Press PLAY/PAUSE to start track play.

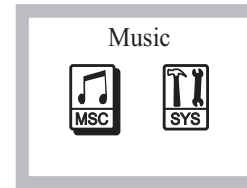

- System Setting: Press & hold PLAY/PAUSE to enter system settings.

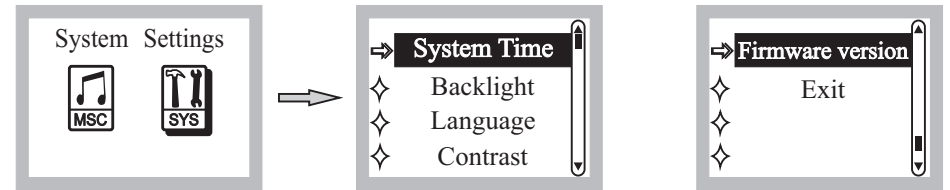

Changing Date & Time

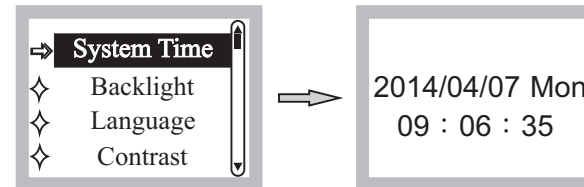

Changing Backlight Brightness Time

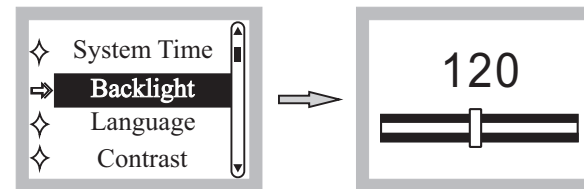

Display track name in one of the 26 languages



Changing LCD display brightness

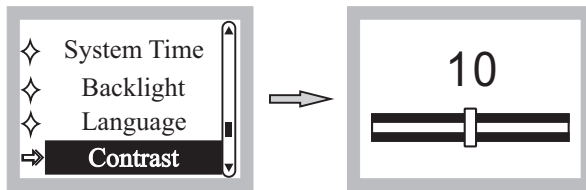

Display Software Version

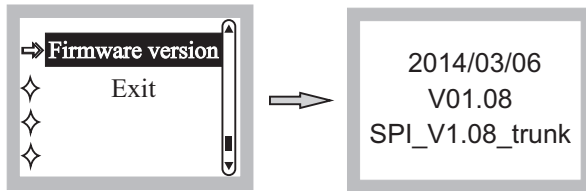

To exit System Setting and return to Music mode

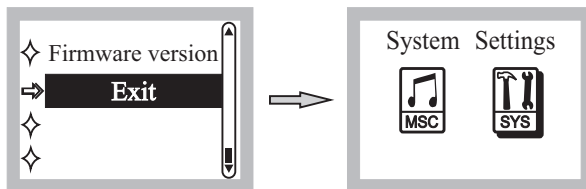

File Browser Operating Instructions

- During track play, press PLAY/PAUSE. PAUSE is displayed. Press & hold to enter File Browser. Press PRV/TEN or NEXT/TEN to select File.

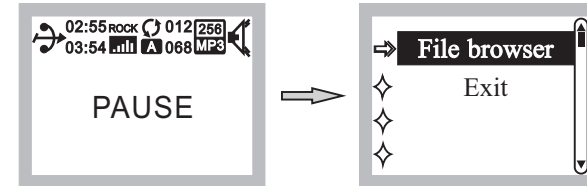

- Press PLAY/PAUSE to enter parameter, press PRV/TEN or NEXT/TEN for selected file. Press PLAY/PAUSE to confirm selection.
- Select "EXIT" & press PLAY/PAUSE to return to PAUSE status.

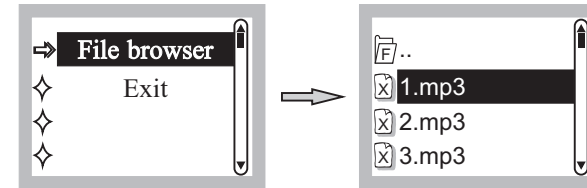

USB REMOTE CONTROLS AND INDICATORS

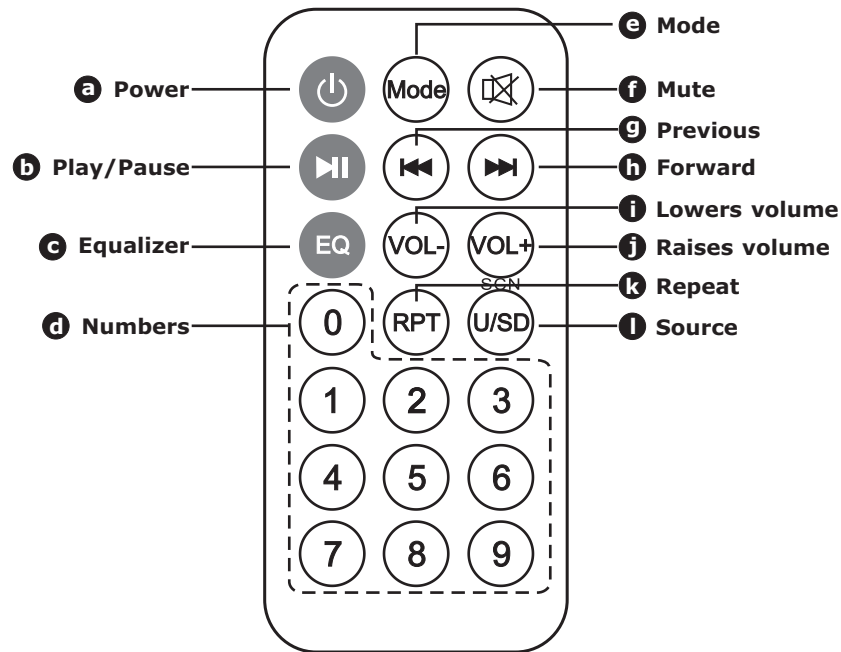

- a Power** :Turns the USB player on/off
- b Play/Pause** :Turns on play or Pauses
- c Equalizer** :Equalizer effects
- d Numbers** :0 ~ 9 (10 numbers)
- e Mode** :Mode selection
- f Mute** :Mutes the audio
- g Previous** :Previous track - Press & release
Fast rewind 10 tracks - Press & hold
- h Forward** :Next track - Press & release
Fast forward 10 tracks - Press & hold
- i Lowers volume**
- j Raises volume**
- k Repeat** :Repeat mode
- l Source** :N/A

REPLACING USB REMOTE BATTERY

- Locate the battery compartment on the bottom of the remote control.
- Press and hold tenon and then slide out the battery tray.
- Remove the old battery and insert the new battery in, making sure that the battery's positive (+) side is facing up.
- Slide the battery tray back into the remote control until it clicks.

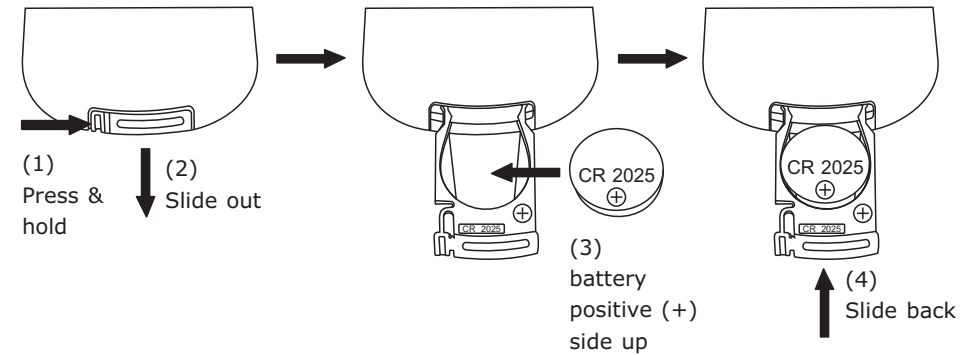



Notes:

- MA-303 uses a CR2025 lithium 3.0V coin battery that is commonly used in small electronic devices. You'll find these batteries at most electronics and drug stores.
- Remote control operates on an infrared (IR)-based technology. If it has an unobstructed line-of-sight, the remote control can function at distances of up to 5 meters (about 17 feet).
- Dispose of the used battery according to local environmental laws and guidelines.

REPLACING THE RECHARGEABLE BATTERY

With a proper care and charging, it is unlikely that the rechargeable battery needs to be replaced by a new battery for some time. You may consider to have a backup battery in case you need to use MA-303 for a longer time. The rechargeable lithium battery is available from MIPRO.

INSTRUCTION OF CHARGING THE RECHARGEABLE BATTERY

- Charge the battery completely in its first use to obtain its maximum capacity.
- Connect to any available AC power outlet using the included DC adapter to the DC IN  jack .
- The battery meter  LED blinks while charging. Blinking LED may start later if the battery suffers from excessive battery drain. The battery may be damaged if the LED does not blink after charging for a while.
 - The battery is low when only the red LED is on. Please recharge the batter for at least 4 hours (the time of charging depends on the type of battery).
 - All LED blinking means the battery is charging.
 - Charging completes when all LED are on.
- Fully charge the battery after each use or minimum once every 3 months.
- Improper maintenance or over discharge the battery will not be covered by the warranty.
- The battery stops charging when it is fully charged. It is safe to leave it connected to the power overnight.

Note:

- The rechargeable battery pack is user replaceable. Rechargeable batteries have a limited number of charge cycles and may eventually need to be replaced. Battery life and number of charge cycles vary by use and settings.

Steps of Changing the Rechargeable Battery

- Lay the PA system on a flat surface. Power off and gently remove USB from USB port, if needed.
- Remove the two screws so the battery cover can be opened and removed.
- The battery pack is stored inside the compartment slot. Pull out the battery gently and remove it completely by detaching the connecting pins.
- Insert the replacement battery pack. Ascertain the connecting pins are connected firmly before inserting. Carefully slide the battery back into the compartment slot.
- Insert back the two screws back in place securely.

Warning:

- Never short-circuit the battery pack by either accidentally or intentionally bringing the battery terminals in contact with another conductive object. Never expose a battery pack to abnormal shock, vibration or pressure. Failure to observe the foregoing could result in serious injury.

Note:

- Dispose of the used battery according to local environmental laws and guidelines.

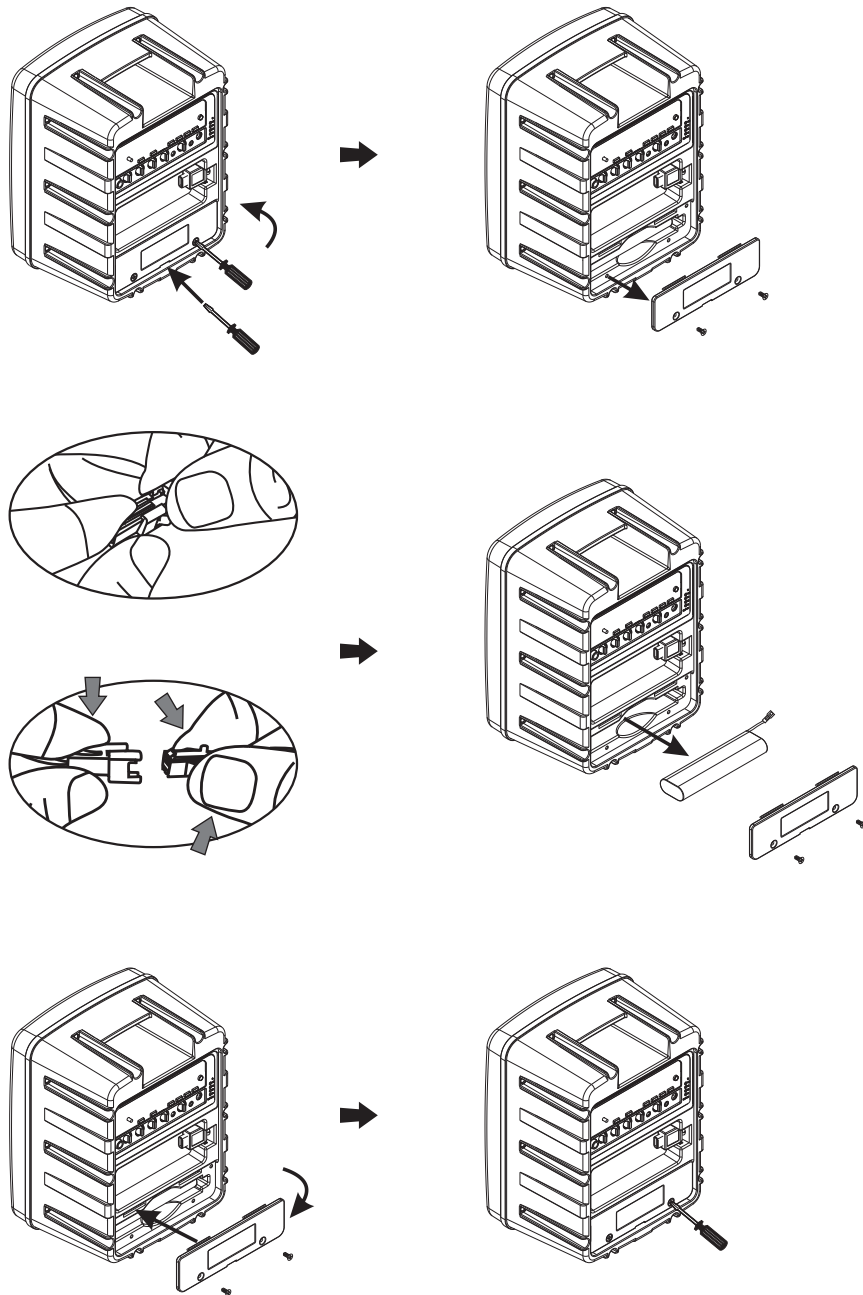

SYSTEM CHANNEL SET-UP

Wireless Mic System

- Turn on master **Power/MIC VOL** switch 31. **Power** indicator 19 glows red. Ready for operation.
- Turn on **CH1 VOL** 32 or **CH2 VOL** 33 VOL switch.
- Turn transmitter power on. Ensure fresh *alkaline* or *lithium* batteries (not included) are installed.
- **RF** indicator 17 or 18 glows green after the transmitter is turned on to denote a successful RF link.
- Adjust **CH1 VOL** 32 or **CH2 VOL** 33 to desired volume.
- Ensure receiver and transmitter have the same matching operating channels. (see page 19: Corresponding Channel Display: MA-303 Receiver and Transmitter) If not, perform ACT Synchronization (Sync) between Receiver and Transmitter Channels (see page 20).

Notes:

- Same wireless microphone can transmit to multiple MA-303 systems on the same channel for a wider and expanded coverage.
- It is not possible to transmit two wireless microphones on the same channel to MA-303 system. Only one transmitter can be used at a time on that channel. Be sure to turn off one of the two transmitters to avoid interference.

Scanning Receiver Channels

- There are 16 channels available. The receiver will scan through the channels in the following order and shown on the LED screen:

1 → 2 → 3 → 4 → 5 → 6 → 7 → 8 → 9 → 0 → A → B → C → D → E → F → 1 → 2 → ...

To Scan for a Clear Receiver Channel

- Press & release the **SCAN/ACT** button until current channel blinks.
- During blinking, press & release the **SCAN/ACT** button a second time.
- The receiver scans and sets at a clear channel automatically.

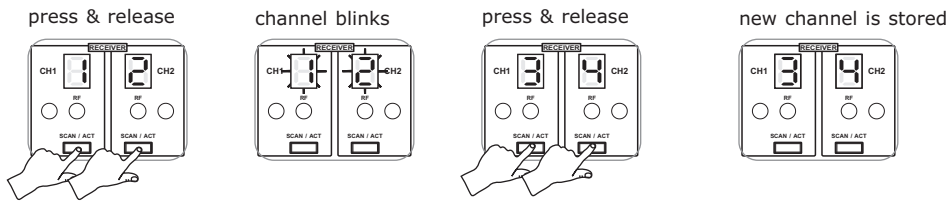

Manually Forcing a Channel Change

- Press & hold the **SCAN/ACT** button until current channel blinks.
- Release the **SCAN/ACT** button until a desired channel is reached.
- This will force the receiver to change to the next available clear channel.

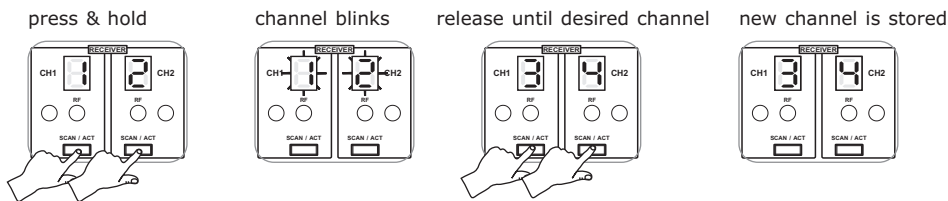

When to Change Channel

- Interference occurs during performance.
- When two or more MA-303s need to be used at the same venue.
- Do not select a new channel while another system is operating as it may interfere.
- If “_” is displayed during channel scanning this indicates the current channel in this frequency band is experiencing interference. If problem persists, it is recommended to change and use a different frequency band.

Corresponding Channel Display: MA-303 Receiver and Transmitter

MA-303	1	2	3	4	5	6	7	8
Transmitter LCD	01 01	01 02	01 03	01 04	01 05	01 06	01 07	01 08
MA-303	9	0	A	B	C	D	E	F
Transmitter LCD	01 09	01 10	01 11	01 12	01 13	01 14	01 15	01 16

ACT Synchronization (Sync) between Receiver and Transmitter Channels

- Power on handheld or bodypack transmitter. Ensure fresh batteries are properly installed with correct polarity.
- Locate and bring the transmitter sync port (red indicator) within 30cm (12-inch) of **CH 1** or **CH 2** receiver sync port **15** or **20**.
- Press and release **SCAN/ACT** button to synchronize receiver and transmitter channels. (See Figure 1)
- During syncing, the channel indicator in **CH 1** **14** or **CH 2** **21** will blink and LCD on the transmitter will display corresponding four digital numbers. (see Corresponding Channel Display: MA-303 Receiver and Transmitter on page 19)
- When the channels are synchronized the channel indicator in channel screen stops blinking and **RF** indicator **17** or **18** glows green to indicate a successful RF link.
- The transmitter is now set to the new channel and ready for operation.
- Repeat steps if channel indicator remains flashing and no glowing green RF indicator.

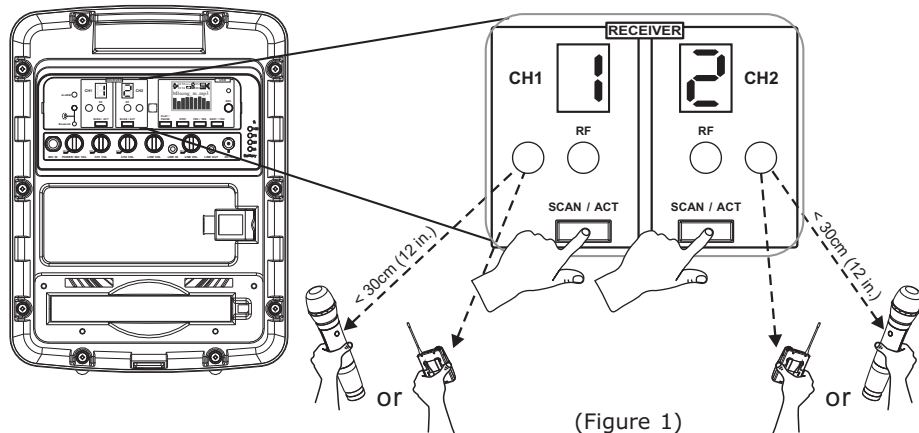

(Figure 1)

OPERATING INSTRUCTIONS

Wired Microphone

- Plug optional MIPRO MM-107 wired dynamic microphone with a 6.3mm (1/4") connector to **MIC IN**.
- Turn on master **POWER/MIC VOL** and adjust to desired volume.

Line Input

- Available to connect an external CD, MP3, iPod or cassette player.
- Connect a 3.5mm-to-3.5mm audio cable (not included) to the **LINE-IN** jack .
- Turn on master **POWER/MIC VOL**.
- Adjust **LINE VOL** to desired volume.

Play USB Drive

- Insert USB drive into USB 2.0 port.
- Turn master **POWER/MIC VOL** power on.
- Turn **USB VOL** power on. Display screen will light when USB player is turned on.
- Press & release **NEXT/TEN** button for next track. Press & hold **NEXT/TEN** button skips forward next 10 tracks.
- Press & release **PRV/TEN** button for previous track. Press & hold **PRV/TEN** button skips backward previous 10 tracks.

Two options for the order of playing music

- Copy the desired songs into USB storage unit one by one until copying all the desired songs. By this way, the play sequency will be based upon the order of music being programed into USB storage unit.
- If the desired songs will be divided into different folders, please number the songs when copying them into folders then copying the said folders into USB storage unit. Pleae note the songs must be numbered by the same digit like 00, 01, 02 or 000, 001, 002 or 0000, 0001, 0002.. and so on.
- Format USB before playback. Format standard is FAT.

Recording & Playback Tracks

- Turn on both POWER/MIC VOL& USB VOL. LED indicator lights will stay on.
- Press STOP to stop play.
- During playback, press REC button, STOP is shown. Press REC button again to enter recording parameter, RED LED stays on. Press REC button again to record, RED LED flashes intermittently.
- During STOP, press REC button, enters recording standby state, REC LED stays on. Press REC button again to record, RED LED flashes intermittently.
- During not recording status, press STOP button turn recorded file into MP3 format. To record again, press REC button to start recording.
- Press PLAY/PAUSE to play the recorded files.

Alarm Siren

- Press **Alarm** button for warnings of approaching or presence of threats or situations requiring immediate attention.
- Alarm will sound only when master **Power/Mic Volume** is powered on and one of below function is powered on.
- A.Wireless transmitter and CH 1 or CH 2 are powered on.
- B.Wired microphone is plugged into the Mic input and powered on.
- C.USB player is powered on & music is playing.

PAIRING BLUETOOTH MUSIC RECEIVER

Play you're your Apple iPhone, iPod touch, or other device enabled with Bluetooth technology wirelessly through the built-in PA speaker.

To Power On

- Press & hold Bluetooth Music Player button for 3-5 seconds until LED indicator light is flashing green/red intermittently. The alternate flashing indicates the unit is powered on and is now ready to be paired to a Bluetooth smart wireless device. However, if green/red is not flashing intermittently this indicates the unit is not ready to be paired.

To Pair Bluetooth Music Player with a wireless Bluetooth device

- Make sure the built-in Bluetooth music receiver is powered on and bring the powered on wireless Bluetooth device within 1 meter of each other.
- Search Bluetooth devices for the music receiver's ID. The device ID is the word 'MIPRO MB-xx or MP-xx' and followed by two numbers for the two XXs. Click on the device ID.
- Enter "0000" when you're prompted to enter a PIN number. This will cause your wireless device to pair with the music receiver.
- Once paired and connection is made successfully, the LED indicator light on the music player will continue to flash intermittently or stay on when connection is established.
- The Bluetooth Music Receiver is now connected and ready to play music. Just play music on your device as you normally would and the sound will come out of the PA speakers.

To Pair Bluetooth Music Player with another wireless Bluetooth device

- Power off the Bluetooth music player first. Then, power on again.
- Repeat steps above to pair to a new Bluetooth device.

To Power Off

- Press & hold Bluetooth Music Player button for 3-5 seconds until LED indicator light is turned off.

TROUBLESHOOTING

Out of Range or Lost Signal

- If the music device is out of range of the Bluetooth Music Receiver or if there is something blocking the Bluetooth signal, the LED light will turn off to indicate that the Bluetooth connection with the music device has been lost. To avoid a lost connection move device closer to the Music Player in a clear, line-of-sight path.
- The connection will automatically be reestablished and the LED light will turn on if the device is move back within seconds.
- If the connection is lost for more than 10 seconds, the connection will need to be reestablished. Follow the directions in "To Pair Bluetooth Music Player with a wireless Bluetooth device".

CONNECTION TO EXTERNAL AUDIO SOURCES

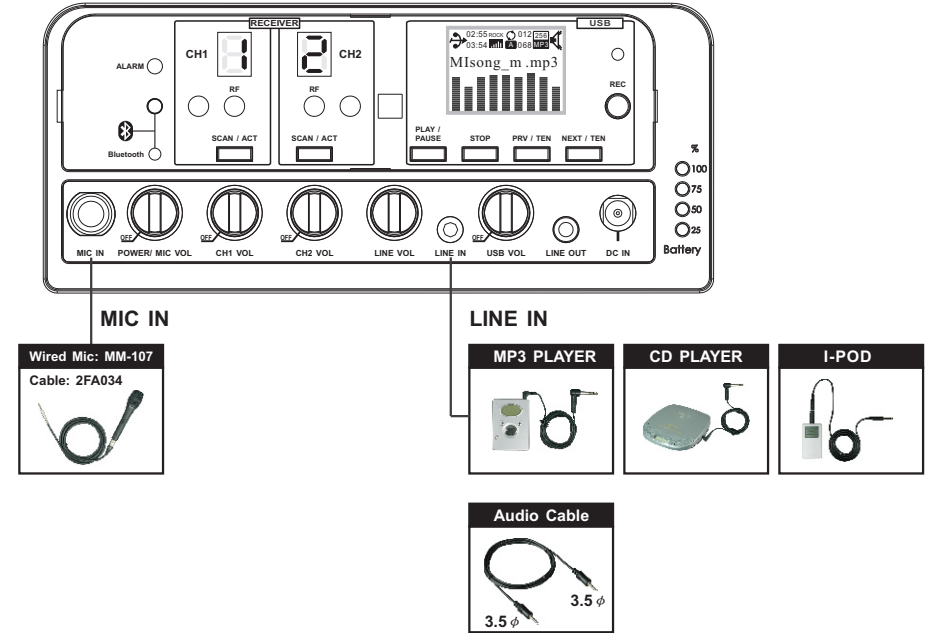

SETUP INSTRUCTION

- Set the base on any 15.8mm (3/8") tripod or on top of MIPRO's MS-90 wall-mounting kit. When done, tighten the knob (see illustrations below)

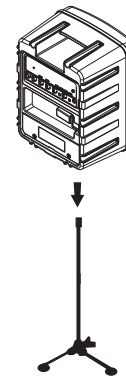

(Setup on a 15.8mm (3/8") tripod)

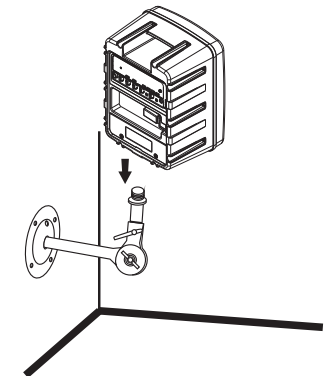

(Setup on to of MS-90 wall-mounting kit)

USB DRIVE OPERATION

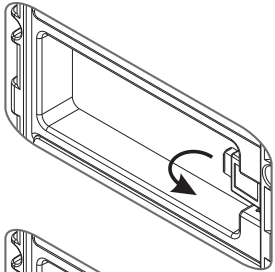

Standard USB port storage position
Pull out the USB port to a 90 degree angle

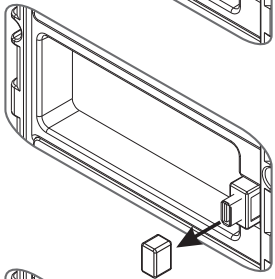

Remove the protective cap

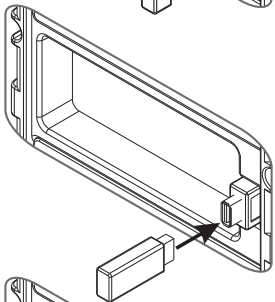

Insert a Type-A USB disk (USB 2.0 interface)

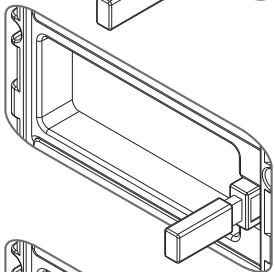

Ensure USB disk is plugged firmly and securely.

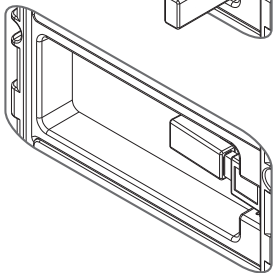

Push back the USB port into the standard position to prevent accidental issues.

SIX AVAILABLE CONFIGURATIONS

MA-303SB Personal Wireless PA System

Single-Channel +USB Player & Recorder +Bluetooth

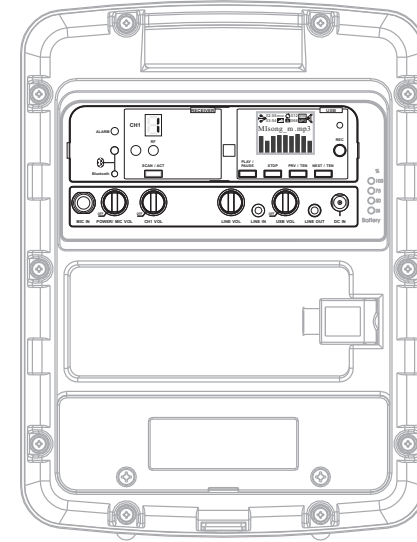

MA-303DB Personal Wireless PA System

Dual-Channel +USB Player & Recorder +Bluetooth

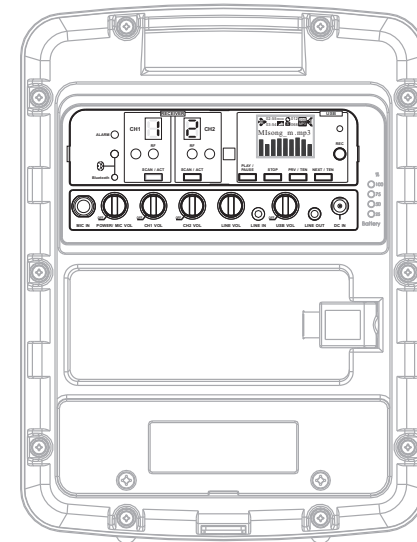

MA-303du Personal Wireless PA System

Dual-Channel +USB Player & Recorder

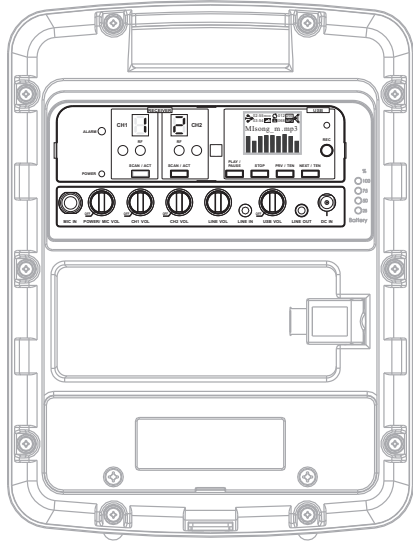

MA-303su Personal Wireless PA System

Single-Channel +USB Player & Recorder

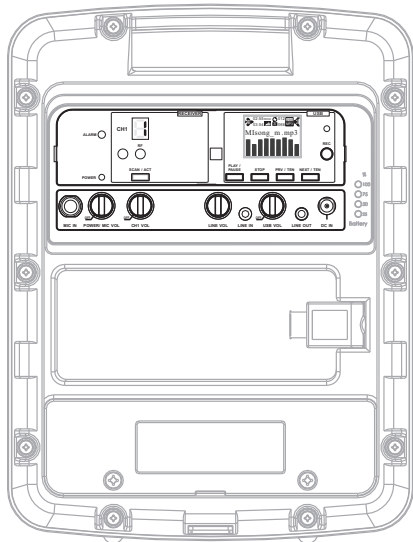

MA-303d Personal Wireless PA System

Dual-Channel. No USB Player & Recorder

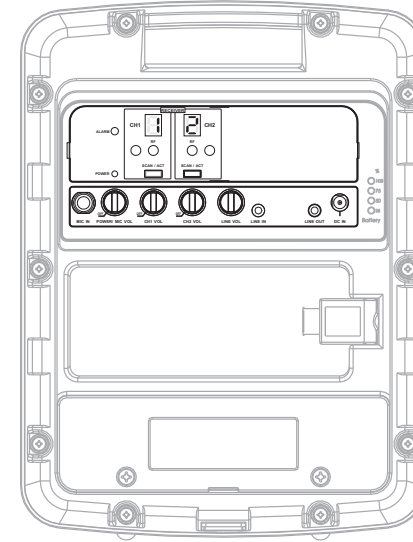

MA-303s Personal Wireless PA System

Single-Channel. No USB Player & Recorder

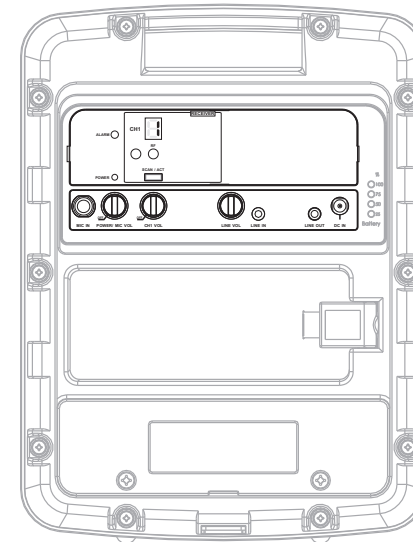

TROUBLESHOOTING-PORTABLE PUBLIC ADDRESS

PROBLEM	POSSIBLE CAUSE	SOLUTION
No Sound or Faint Sound From Speaker	Volume turned down	Adjust volume
	Power switch is turned off	Turn power switch on
Power Indicator Not On	Power switch is turned off	Turn power switch on
	Rechargeable Battery is discharged	Plug into AC outlet to recharge
	Rechargeable Battery is "dead"	Replace battery and plug into AC outlet to recharge
Distorted Sound From Speaker	Volume set too high	Reduce volume
	Excessive wind noise or breath "pops"	Use windscreen on wireless & wired microphones.
	Input signal too strong	Adjust input signals
Excessive Feedback	Microphone too close or directly in front of the speaker	Move microphone away from the speaker
	Volume set too high	Reduce volume
	Microphone too far from sound source (requiring the volume to be turned up to compensate)	Speak closer to the microphone or move microphone closer to sound source
Weak, Distorted Sound. Power Indicator Flickers	Batteries level is low	Plug into AC outlet to recharge
Excessive Hum or Noise	Input Cable not shielded	Use shielded cable
Shortened Battery Life	Old or overused battery	Recharge or replace battery
	Battery is not charged for over 3~4 months	Recharge or replace battery
Battery CHARGE Indicator Not Flickering when plugged into AC Outlet	Rechargeable Battery is "dead"	Replace battery
	Battery is not charged for over 3~4 months	Recharge or replace battery
	Battery is fully charged (CHARGE indicator is lit)	N/A

TROUBLESHOOTING-WIRELESS MICROPHONE SYSTEMS

PROBLEM	POSSIBLE CAUSE	SOLUTION
No Sound From Speaker	Master or receiver volume turned down	Adjust volumes
	Transmitter or receiver switch is turned off	Turn transmitter or receiver switch on
	Receiver and transmitter have different frequencies	See "Set-up Receiver & Transmitter Frequencies" section
	Transmitter battery is low or no battery inside	Replace or insert new battery
Distortion or Unwanted Noise Bursts	Interference	Remove nearby sources of RF interference (computers, amplifiers, karaoke machines, digital effects, CD players, etc)
	Noise Indicator is lit	Adjust "Sensitivity" on receiver. If problem persists, change Receiver & Transmitter frequencies. See "Set-up Receiver & Transmitter Frequencies" section
Sound Dropouts	Out of operating range	Move transmitter closer to receiver
	Obstructions between the receiver and transmitter	Remove obstructions or reposition
		Line-of-sight between receiver & transmitter
	Weak Transmitter Battery	Replace Transmitter Battery
Interference	Change Receiver & Transmitter frequencies	
	See "Set-up Receiver & Transmitter Frequencies" section	

FAQ - PORTABLE PA

Q: How to adjust for optimal sound volume?

A: If the portable system has both Master & Microphone volumes, we recommend turning the Master volume to about 3pm (clockwise) first and about 1~2pm (clockwise) for Microphone or other volumes.

Q: How to prevent and minimize the annoying feedback?

A1: Do not stand directly in front of the speakers; keep mics away from speakers.

A2: Avoid pointing microphone towards the speakers.

A3: The microphones should be behind the speakers wherever possible.

A4: Locate the portable PA between the crowd and the presenters and facing the crowd.

A5: Turn down the sound level coming out of the portable PA / speakers if necessary.

A6: Place the speakers above the head of the crowd.

Q: What if I need more power to cover a larger crowd?

A: Two or more portables can be used with one wireless microphone transmitter. Ascertain that the receiver frequency in each portable coincides with the wireless microphone.

Q: Can I play music through the systems?

A: Yes. All MIPRO portables have auxiliary inputs (3.5mm min-jack, RCA or 1/4"phone), which will accept input from an external iPod, MP3, CD, cassette, VCR, DVD players. As well, modular CD players can be inserted into most models.

FAQ - RECHARGEABLE BATTERY

Q: How to Charge the Battery?

A: Simply plug into a power outlet using the included power cable and adapter. "Flashing" LED indicates it is charging. The main power switch can be on or off position during charging. Microphones or music can be used during charging & power is on.

Q: How to Spot System Low Battery?

A: When Power LED is lit (MA-705 & MA-707) or Charge LED is lit (MA-101& MA-101a) or one indicator remaining in battery meter (MA-100, MA-202, MA-303, MA-505, MA-708, MA-808). Plug into a power outlet to re-charge ASAP.

Q: Average Life Span of Rechargeable Lithium or Sealed Lead-Acid Battery?

A: The batteries should have a life of up to 2 years if used and maintained properly. Battery life is determined by temperature, depth and rate of discharge, and the number of charges and discharges (called cycles).

Q: When to Replace the Battery?

A1: Power LED indicator is not "lit" when power on. (No battery voltage).

A2: LED indicator or meter is not "flashing" when plugged-in.

A3: Getting 1~2 hours operating time per charge.

A4: When battery has been used extensively for 2 years or more.

RECHARGEABLE BATTERY GUIDE

Tips - To Prolong the Life of Rechargeable Batteries

- Power off the portable system and transmitter/mic when NOT in use.
- Store portable system with batteries in a fully charged condition.
- Most lithium-ion polymer batteries use a fast charge to charge your device to 80% battery capacity, then switch to trickle charging. That's about two hours of charge time to power up to 80% capacity, then another two hours to fully charge it, if you are not using the portable PA system while charging.
- The battery prefers a partial rather than a full discharge. A partial discharge reduces stress and prolongs battery life.
- Avoid frequent full discharges because this puts additional strain on the battery. Several partial discharges with frequent recharges are better for lithium-ion than one deep one.
- Avoid keeping the battery at full charge and high temperature.
- It is OK to leave the system plugged into a power outlet when not being used for a long time. The built-in automatic protection circuitry will auto shut-off when fully charged. It will not harm the system or the battery.
- Fully charge the system at least once every 3~6 months. Battery may not charge if not charged for a prolonged periods of time.
- Do not freeze the battery. Store in dry, cool place away from heat. Elevated temperature reduces battery lifespan.
- Rechargeable batteries have a limited number of charge cycles and may eventually need to be replaced. Battery life and number of charge cycles vary by use and settings.

CAUTION: DO NOT recharge other types of batteries and connect a battery's negative terminal to another batteries positive terminal. An explosion and/or a fire could occur as a result. Use only authorized rechargeable lithium batteries.

OPTIONAL MA-303 ACCESSORIES

MB-10: 14.8V/2.6AH Rechargeable Lithium Battery

MA-303 requires 1 MB-10 batteries

MS-30: Microphone Tripod Stand

Adjustable stand for MA-303 portable PA system

SC-30: Carrying Case

Carrying case and storage. Storage for wireless & wired microphones cable, battery

MM-107: Handheld Wired Microphone

MIPRO's Hypercardioid Dynamic Microphone with cable.

ASP-10: Aerobic Sports Pouch

Sweat-resistant transmitter pouch belts for MIPRO bodypack transmitters.

MIPRO WIRELESS MICROPHONE SYSTEMS FOR MA-303

ACT-30H/ACT-32H - Handheld Transmitter Microphone (2 AA : not included)

ACT-30T/ACT-32T - Body Pack Transmitter (2 AA : not included)

(microphone not included - see below)

MU-53HN (black) ; MU-53HNS (beige) - Premium Headworn Microphone

Uni-directional, Premium 10mm, Ideal for speech and singing. Works with all MIPRO bodypack transmitters

MU-55HN (black) ; MU-55HNS (beige) - Subminiature Headworn Microphone

Omni-directional, 4.5mm, Sweat-proof, Ideal for speech. Works with all MIPRO bodypack transmitters

MU-13 (beige) - Premium Single-sided Earworn Microphone

Omni-directional, ultra small & lightweight 3mm, Ideal for speech. Works with all MIPRO bodypack transmitters

MU-23 (beige) - Premium Dual-sided Headworn Microphone

Omni-directional, ultra small & lightweight 3mm, Ideal for speech. Works with all MIPRO bodypack transmitters

MU-53L (black) ; MU-53LS (beige) - Premium Lavalier Microphone

Uni-directional, 10mm, High-gain-before-feedback, warm, clear sound. Works with all MIPRO bodypack transmitters

MU-55L (black) ; MU-55LS (beige) - Subminiature Lavalier Microphone

Omni-directional, 4.5mm, Low visibility, Works with all MIPRO bodypack transmitters