

Inside Micrometers

Tubular Inside Micrometers SERIES 137 — Extension-Rod Type (main unit)

- Micrometer head for Extension-Rod Type inside micrometer.
- The sleeve is rotated to adjust the reference point adjustment when setting to a length standard.
- Optional Setting Rings and Gauge Block Accessory Sets are available as reference gages for datum adjustment. (Refer to pages C-52 and E-17 to E-20 for details)



137-011

SPECIFICATIONS

Metric				
Order No.	Range (mm)	Spindle feed error* (μm)	Graduation (mm)	Micrometer head stroke (mm)
137-011	50 - 63	3	0.01	13
Carbide-tipped 137-013				

Inch				
Order No.	Range (in)	Spindle feed error* (in)	Graduation (in)	Micrometer head stroke (in)
137-012	2 - 2.5	0.00015	0.001	0.5
Carbide-tipped 137-014				

* "Spindle feed error" refers to the difference between the maximum and minimum indication error values within the specification range of the micrometer head

DIMENSIONS

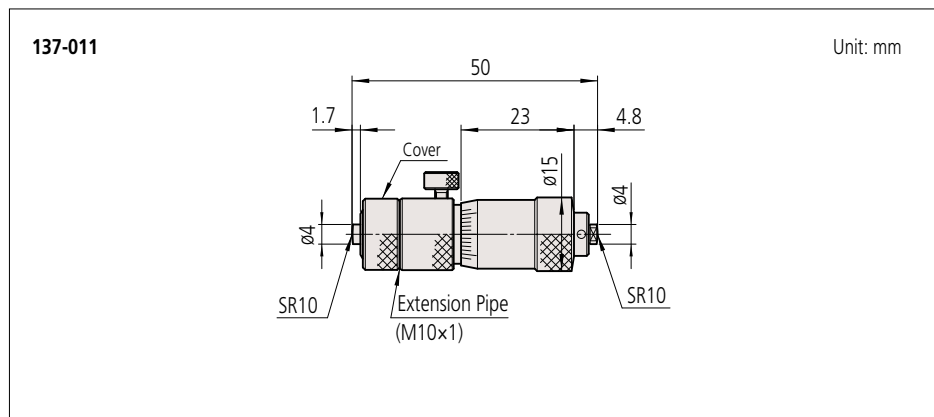

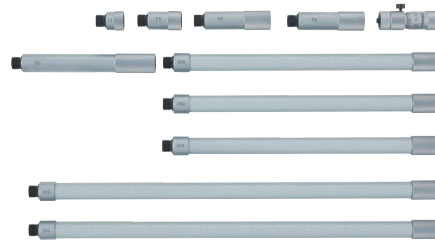

137-205

SPECIFICATIONS

Metric

Order No.	Range (mm)	Graduation (mm)	Spindle feed error* (μm)	Micrometer head stroke (mm)	Extension rods		Main unit (mm)
					Qty	Size (mm)	
137-201	50 - 150	0.01	3	13	3	13, 25, 50	50 - 63
137-202	50 - 300				5	13, 25, 50 (2 pcs.), 100	
137-203	50 - 500				6	13, 25, 50 (2 pcs.), 100, 200	
137-204	50 - 1000				8	13, 25, 50 (2 pcs.), 100, 200 (2 pcs.), 300	
137-205	50 - 1500				10	13, 25, 50 (2 pcs.), 100, 200 (3 pcs.), 300 (2 pcs.)	
With carbide measuring face							
137-206	50 - 150	0.01	3	13	3	13, 25, 50	50 - 63
137-207	50 - 300				5	13, 25, 50 (2 pcs.), 100	
137-208	50 - 500				6	13, 25, 50 (2 pcs.), 100, 200	
137-209	50 - 1000				8	13, 25, 50 (2 pcs.), 100, 200 (2 pcs.), 300	
137-210	50 - 1500				10	13, 25, 50 (2 pcs.), 100, 200 (3 pcs.), 300 (2 pcs.)	

Inch

Order No.	Range (in)	Graduation (in)	Spindle feed error* (in)	Micrometer head stroke (in)	Extension rods		Main unit (in)
					Qty	Size (in)	
137-211	2 - 6	0.001	0.00015	0.5	3	0.5, 1, 2	2 - 2.5
137-212	2 - 12				5	0.5, 1, 2 (2 pcs.), 4	
137-213	2 - 20				6	0.5, 1, 2 (2 pcs.), 4, 8	
137-214	2 - 40				8	0.5, 1, 2 (2 pcs.), 4, 8 (2 pcs.), 12	
137-215	2 - 60				10	0.5, 1, 2 (2 pcs.), 4, 8 (3 pcs.), 12 (2 pcs.)	
With carbide measuring face							
137-216	2 - 6	0.001	0.00015	0.5	3	0.5, 1, 2	2 - 2.5
137-217	2 - 12				5	0.5, 1, 2 (2 pcs.), 4	
137-218	2 - 20				6	0.5, 1, 2 (2 pcs.), 4, 8	
137-219	2 - 40				8	0.5, 1, 2 (2 pcs.), 4, 8 (2 pcs.), 12	
137-220	2 - 60				10	0.5, 1, 2 (2 pcs.), 4, 8 (3 pcs.), 12 (2 pcs.)	

* "Spindle feed error" refers to the difference between the maximum and minimum indication error values within the measuring range of the micrometer head

DIMENSIONS

