

# Micrometer

**MeasurLink<sup>®</sup> ENABLED**  
Data Management Software by Mitutoyo

## Digimatic Outside Micrometers SERIES 293

- Constant measuring force: ratchet stop
- Interface Input Tools are available that enable the conversion of measurement data to keyboard signals that are then

directly input to cells in off-the-shelf spreadsheet software such as Excel. (Refer to page A-5 for details.)

- Measuring faces: Carbide



### SPECIFICATIONS

Metric						
Order No.	Range (mm)	Resolution (mm)	Measuring force (N)	Maximum permissible error $J_{MPE}$ ( $\mu\text{m}$ )	Flatness ( $\mu\text{m}$ )	Parallelism ( $\mu\text{m}$ )
293-582	300 - 325	0.001	10 - 15	±6	0.6	5
293-583	325 - 350					
293-584	350 - 375					
293-585	375 - 400			±7		6
293-586	400 - 425					
293-587	425 - 450			±8		7
293-588	450 - 475					
293-589	475 - 500					

Inch/Metric						
Order No.	Range (in)	Resolution	Measuring force (N)	Maximum permissible error $J_{MPE}$ (in)	Flatness (in)	Parallelism (in)
293-782	12 - 13	0.0001 in / 0.001 mm	10 - 15	±0.0003	0.000024	0.0002
293-783	13 - 14					
293-784	14 - 15			±0.00035		0.00024
293-785	15 - 16					
293-786	16 - 17					
293-787	17 - 18			±0.0004		0.00028
293-788	18 - 19					
293-789	19 - 20					

- SR44 (2 pcs.), **938882**, for initial operational checks (standard accessory)
- Battery life: Approx. 1.8 years under normal use
- Length standard: Electromagnetic rotary sensor
- Standard accessories: Setting standard, 1 pc., Spanner (**200154**), 1 pc.

### DIMENSIONS

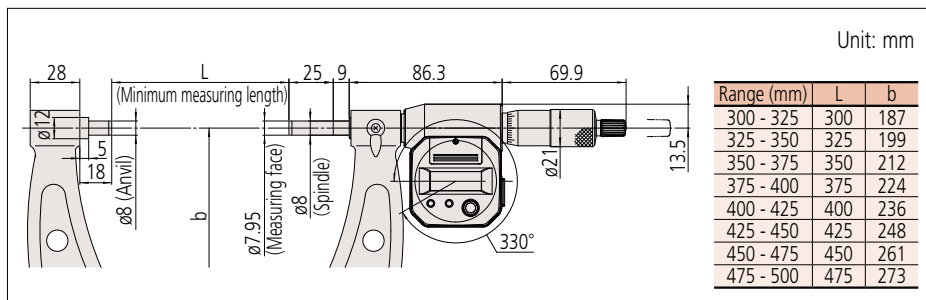

### Functions

**Origin point setting** (ABS measurement system): Resets the ABS origin at the current spindle position to the minimum value of the measuring range and switches to ABS mode.

**Zero-setting** (INC measurement system): A brief press on the ZERO/ABS button sets display to zero at the current spindle position and switches to the incremental (INC) measuring mode. A longer press resets to the ABS measuring mode.

**Hold:** Pressing the HOLD button freezes the current value in the display. This function is useful for preserving a measurement in situations of poor visibility where the instrument must be moved away from the workpiece before the reading can be recorded.

**Function lock:** This function allows the PRESET (origin point setting) function and the ZERO (zero-setting) function to be locked to prevent these points being reset accidentally.

**Auto power ON / OFF:** The reading on the LCD disappears after this instrument is idle for about 20 minutes, but the reading and measurement mode are retained. Turning the spindle causes the reading to reappear.

**Data output:** Models equipped with this function have an output port for transferring measurement data to a Statistical Process Control (SPC) system.

**Error alarm:** In case of an overflow on the LCD or a computing error, an error message appears on the LCD, and the measuring function stops. This prevents an instrument from giving an erroneous reading. Also, when the battery voltage drops to a certain level, the low-battery-voltage alarm indicator appears well before the micrometer becomes unusable.

### Optional Accessories

Order No.	Type	Description
04AZB512	CR	Connecting cable (1 m)
04AZB513	CR	Connecting cable (2 m)
959149	C	Connecting cable (1 m)
959150	C	Connecting cable (2 m)