

Small Hole Gage Set

SERIES 154

FEATURES

- Used with an outside micrometer for measuring inside diameter of bores.
- 4 sizes of gages are supplied in a fitted pouch.
- Extra long for gaging deep and shallow holes, slots and similar workpieces.
- Gaging surface is fully hardened to ensure long tool life.



154-901

DIMENSIONS

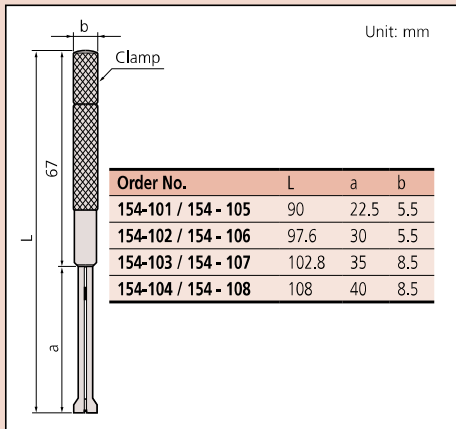

SPECIFICATIONS

Metric		
Total range	Set Order No.	Assortment of gages
ø3 - 13mm (4-gage set)	154-902	ø3 - 5mm gage (154-101)
		ø5 - 7.5mm gage (154-102)
		ø7.5 - 10mm gage (154-103)
		ø10 - 13mm gage (154-104)

Inch		
Total range	Set Order No.	Assortment of gages
.125 - .5" DIA. (4-gage set)	154-901	.125" - .2" DIA. gage (154-105)
		.2" - .3" DIA. gage (154-106)
		.3" - .4" DIA. gage (154-107)
		.4" - .5" DIA. gage (154-108)

Telescoping Gage Set

SERIES 155

FEATURES

- Spring-loaded plunger expands within the bore (or groove), allowing determination of the internal diameter (or groove width).
- With a knurled clamp.
- Supplied in a fitted pouch.



155-903

DIMENSIONS

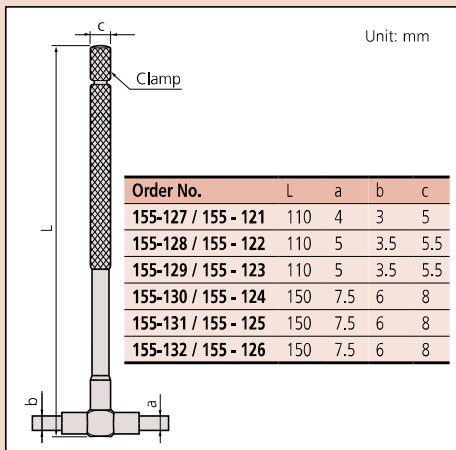

SPECIFICATIONS

Metric		
Total range	Set Order No.	Included in set
8 - 150mm (6-gage set)	155-905	8 - 12.7mm gage (155-127)
		12.7 - 19mm gage (155-128)
		19 - 32mm gage (155-129)
		32 - 54mm gage (155-130)
		54 - 90mm gage (155-131)
		90 - 150mm gage (155-132)

Inch		
Total range	Set Order No.	Included in set
.313 - 6" (6-gage set)	155-903	.313" - .5" gage (155-121)
		.5" - .75" gage (155-122)
		.75" - 1.25" gage (155-123)
		1.25" - 2.125" gage (155-124)
		2.125" - 3.5" gage (155-125)
		3.5" - 6" gage (155-126)
.50 - 6" (5-gage set)	155-904	155-122, 155-123, 155-124, 155-125, 155-126
.315 - 2.125" (4-gage set)	155-907	155-121, 155-122, 155-123, 155-124