

Height Gage

Vernier Height Gage SERIES 514, 506 — Standard Height Gage with Adjustable Main Scale

- Fits comfortably in the hand and moves easily on the surface plate.
- Carbide-tipped scriber is provided as a standard accessory.
- The main scale slides and clamps within the column for quick and convenient zero-setting.



Standard Accessories

Order No.	Description	Models
07GZA000	Carbide-tipped scriber	514-102, 514-104, 514-106, 514-103, 514-105, 514-107
905200	Carbide-tipped scriber	514-108, 514-109
05GZA033	Scriber clamp	514-102, 514-104, 514-106, 514-108, 514-103, 514-105, 514-107, 514-109

SPECIFICATIONS

Metric

Order No.	Range (mm)	Minimum reading (mm)	Scale adjustment (mm)	Fine feed (mm)	Maximum permissible error E_{MPE} (mm)*	Height (mm)	Mass (kg)
506-207	0 - 200	0.02	—	4	±0.03	341	1.4
514-102	0 - 300		15		7	±0.04	525
514-104	0 - 450			6	±0.05	675	3.4
514-106	0 - 600				7	±0.05	870
514-108	0 - 1000		25	6	±0.07	1340	20

Inch / Metric

Order No.	Range (in)	Minimum reading	Scale adjustment (in)	Fine feed (in)	Maximum permissible error E_{MPE} (in)*	Height (mm)	Mass (kg)
506-208	0 - 8	0.001 in/0.02 mm	—	0.16	±0.001	341	1.4
514-103	0 - 12		0.6		0.27	±0.002	525
514-105	0 - 18			1	±0.002	675	3.4
514-107	0 - 24				0.24	±0.002	870
514-109	0 - 40		1	0.24	±0.003	1340	20

• Reading magnifier (optional): 514-102/104/106: 07GZA003, 514-108: 07GZA015

* Maximum permissible error, E_{MPE} is the term (notation) used in JIS B 7517: 2018, revised based on ISO/TR 14253-6: 2012.

DIMENSIONS

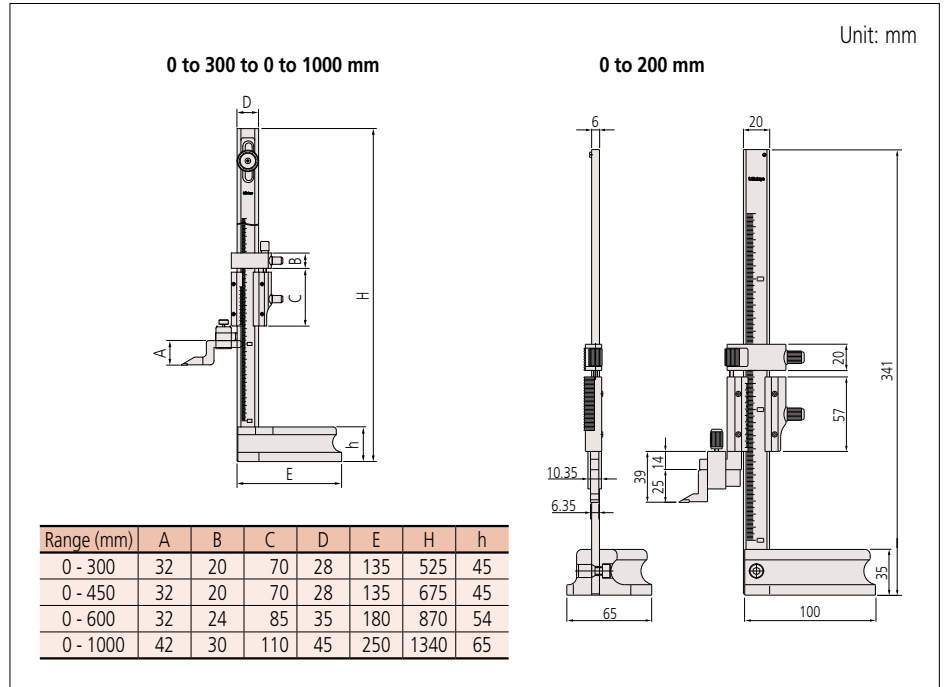

D