

LINEAR SCALE DRO SYSTEMS

Linear Scales, Counters, & DRO Retrofit Packages

DIGITAL SCALE AND DRO SYSTEMS



Accurate and Affordable DRO System



Mitutoyo's Linear Scale Systems tightly couple linear scale units with dedicated digital readout (DRO) units in order to accurately detect and display displacements for machine tools, measuring tables, 3D printers, XY tables, or any application requiring measured lengths or accurate positioning. Packages are available for popular machine sizes or systems can be configured to best meet your specific application. Scale units have many measuring length ranges and the display units feature remote zero setting, switchable resolution and multipurpose one-touch macro keys. The Linear Scale System is easy to use and reliable, which can dramatically improve machining accuracy and efficiency.

Table of Contents

| | |
|---|----|
| Scale Unit Selection Guide..... | 3 |
| AT715, ABSOLUTE and High Environmental Resistance Type..... | 4 |
| AT103, Standard-size Type..... | 6 |
| AT113, Slim Type..... | 8 |
| AT116, Slim and Economy Type..... | 9 |
| AT112-F, Super Slim Type..... | 10 |
| Display Unit Features..... | 11 |
| KA-200 Counter..... | 12 |
| Display Unit Functions..... | 14 |
| Milling Packages..... | 16 |
| Lathe Packages..... | 20 |
| Grinding Packages..... | 22 |
| Connecting to External Devices..... | 24 |
| Optional Accessories..... | 26 |
| Optional Adapters..... | 30 |
| Precautions when Mounting and Handling Linear Scales..... | 32 |
| Operating Principles..... | 34 |
| Scale Systems for Various Multi-axis Machine Tools..... | 35 |
| Applications..... | 36 |

Features of the Linear Scale System

- Digital counter value display allows quick and accurate readout of displacement.
- Zero-setting or presetting possible at any position. Versatile functions eliminate calculations or complicated key operations for positioning.
- Various external output features allow output of current display values or various data to external devices such as PCs or PLCs. Easy data processing can be performed.
- Two types of display units available: high-performance type and limit-signal type.
- Both linear scale and display units conform to CE marking standards.
- Mitutoyo actively promotes global environmental conservation. Our products do not have chemical content in excess of levels permitted in the RoHS Directive as prescribed in the EU. (As of May 2015)

Ultra Precision Manufacturing 11 Meters Underground

Mitutoyo Kiyohara Plant, which is a factory exclusively for the production of linear scales and other precision scales, has a complete system for producing master scales to be used in finished products, such as CMMs, vision measuring systems, profile projectors, and measuring microscopes. To improve the accuracy of scales and quality control technologies, the integral laboratory at the Kiyohara Plant was constructed eleven meters underground. It provides an optimal environment (cleanliness factor: 100) for the ultra-precision manufacture and evaluation of scales. Its unique design and construction isolates the laboratory from external vibrations and ensures minimal variations in temperature and humidity.



Scale Unit Selection Guide

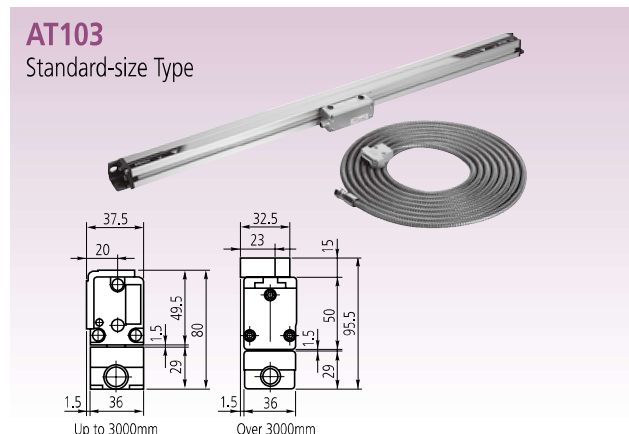
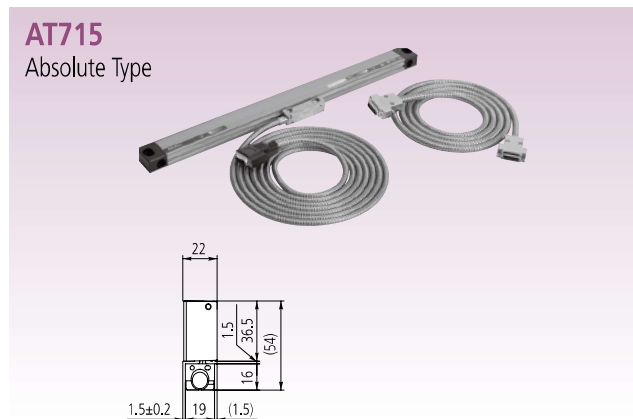

Specifications

| Model | AT715 | AT103 | AT113, AT116 | AT112-F |
|---|--|--|--|--|
| Measurement method | Electromagnetic induction system | Photoelectric (transparent linear encoder) | | |
| Light source | — | LED | | |
| Receptor | — | Phototransistor | | |
| Output wave form | — | 2-phase sine curves with a phase difference of 90° | | |
| Max Resolution | .000020" (20μm)/0.5μm | .000005" (5μm)/0.1μm | | |
| Effective length (for high-accuracy type) | 100 - 3000mm | 100 - 6000mm (100 - 2000mm) | 100 - 1500mm (100 - 1500mm) | 50 - 1020mm (50 - 1020mm) |
| Accuracy* [high-accuracy type] | ±5μm (Effective length: 100 - 500mm) ±7μm (Effective length: 600 - 1800mm) ±10μm (Effective length: 2000 - 3000mm) | (5+5L ₀ /1000)μm*1 [(3+3L ₀ /1000)μm] | (5+5L ₀ /1000)μm [(3+3L ₀ /1000)μm*2] | (5+5L ₀ /1000)μm [(3+3L ₀ /1000)μm] |
| Maximum response speed | 50m/min. | 120m/min.*3 | 120m/min. (50m/min.: AT116) | 50m/min. |
| Scale reference point | Absolute system | At every 50mm interval | | |
| Linear expansion coefficient | — | (8±1)×10 ⁻⁶ /°C | | |
| Power supply | 5V±5% DC | 5V±5% DC | | |
| Max, current consumption | 70mA | 70mA*4 (60mA: AT113, AT116) | | |
| Operating temperature | 0°C to 45°C | | | |
| Storage temperature | -20°C to 70°C | | | |
| Relative humidity | 20 - 80%RH | | | |
| Head cable length | — | — | *6 | 0.3m |
| Sliding force | 5N or less | 5N or less | | |
| Single cable*5 | Standard accessory (refer to individual specifications for the length) | | | |
| Dust/water protection level | IP67 | IP53 | | |

*1: (5+8L₀/1000)μm for models over 3250mm effective length *2: not available for AT116

*3: 50m/min. for models over 3250mm effective length

*4: 140mA for models over 3250mm effective length

*5: Vinyl-coated type single cable and extension cable are available on request.

*6: AT103:0.3m AT116: Without head cable

AT715, ABSOLUTE and High Environmental Resistance Type Using ABSOLUTE® Electromagnetic Induction System

Features

- Employs the ABSOLUTE® electromagnetic induction system* to achieve IP67 environmental resistance.
- Detects and outputs an absolute position - reference point setup not necessary every time unit is turned on.
- An abnormal calculation doesn't accumulate even if the calculation mistake is generated by electrical noise.
- Two mounting directions of the main scale unit allows easy mounting on a machine tool with difficult mounting arrangements.
- Resolution: down to .000020" (20µin)/0.5µm (selectable resolution per display)

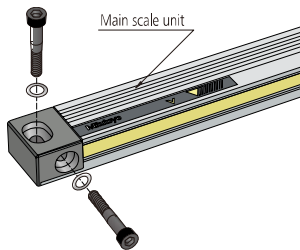

* Patent registered (Japan, USA, India, China, Germany, UK, France, Switzerland)

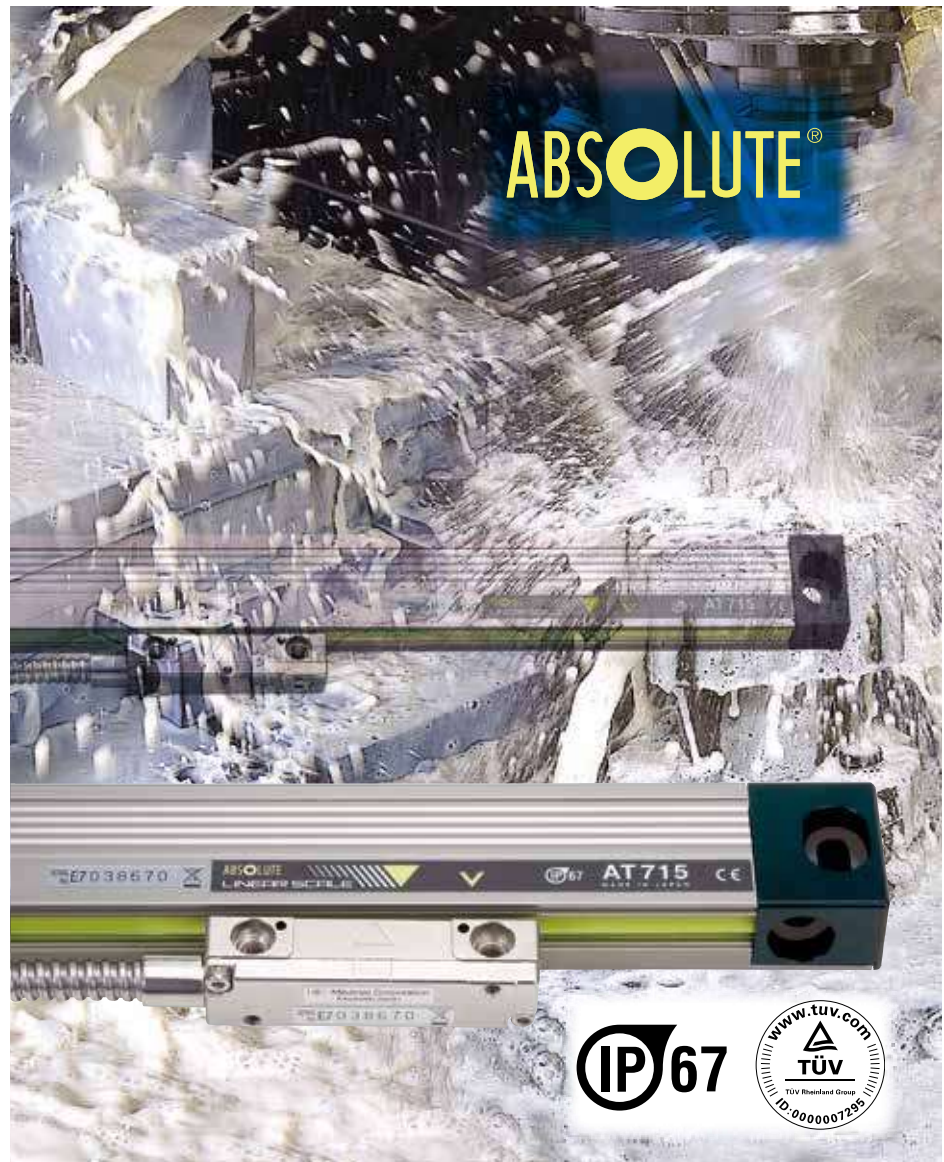

Extension cable*

| Order No. | Cable length |
|-----------|----------------|
| 09AAB674A | 2m (6.5 feet) |
| 09AAB674B | 5m (16.4 feet) |
| 09AAB674C | 7m (22.9 feet) |

Mounting parts (provided as standard)

| Items included | Quantity |
|---------------------------------|------------|
| • Hex-socket head screw (M6x25) | 2 pcs. |
| • Hex-socket head screw (M4x25) | 2 pcs. |
| • Hex-socket head screw (M4x8) | 6 pcs. |
| • Plain washer (6mm nominal) | 2 pcs. |
| • Plain washer (4mm nominal) | 2 pcs. |
| • Cable clip | 6 pcs. |
| • Spacer (0.3, 0.4, 0.5, 0.6mm) | 1 pc. each |

*: Max total length including the signal cable : 15m.

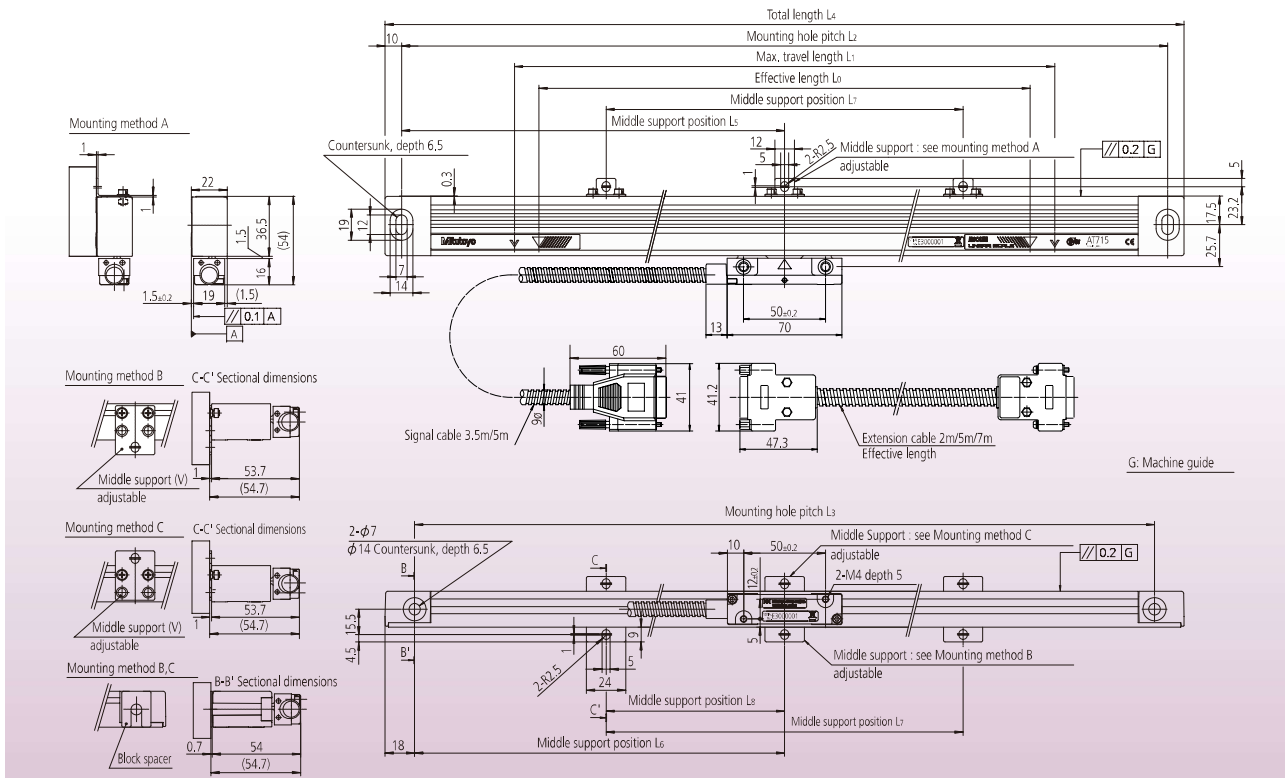

Order No. and mounting dimensions

mm (inch)

| Order No. / Model No. | Effective length L ₀ | Maximum travel length L ₁ | Mounting hole pitch L ₂ | Mounting hole pitch L ₃ | Overall length L ₄ | Middle support positions | | | Signal cable length |
|-----------------------|---------------------------------|--------------------------------------|------------------------------------|------------------------------------|-------------------------------|--------------------------|----------------|----------------|---------------------|
| | | | | | | L ₅ | L ₆ | L ₇ | |
| 539-801 / AT715-100 | 100(4") | 120(4.72") | 258(10.16") | 242 (9.53") | 278(10.94") | — | — | — | 3500 (137.80) |
| 539-802 / AT715-150 | 150(6") | 170(6.69") | 308(12.13") | 292 (11.50") | 328(12.91") | — | — | — | |
| 539-803 / AT715-200 | 200(8") | 220(8.66") | 358(14.09") | 342 (13.46") | 378(14.88") | — | — | — | |
| 539-804 / AT715-250 | 250(10") | 270(10.63") | 408(16.06") | 392 (15.43") | 428(16.85") | — | — | — | |
| 539-805 / AT715-300 | 300(12") | 330(12.99") | 468(18.43") | 452 (17.80") | 488(19.21") | — | — | — | |
| 539-806 / AT715-350 | 350(14") | 380(14.96") | 518(20.39") | 502 (19.76") | 538(21.18") | — | — | — | |
| 539-807 / AT715-400 | 400(16") | 430(16.93") | 568(22.36") | 552 (21.73") | 588(23.15") | — | — | — | |
| 539-808 / AT715-450 | 450(18") | 480(18.90") | 618(24.33") | 602 (23.70") | 638(25.12") | — | — | — | |
| 539-809 / AT715-500 | 500(20") | 540(21.26") | 678(26.69") | 662 (26.06") | 698(27.48") | 339(13.35") | 331(13.03") | — | |
| 539-811 / AT715-600 | 600(24") | 640(25.20") | 778(30.63") | 762 (30.00") | 798(31.42") | 389(15.31") | 381(15.00") | — | |
| 539-813 / AT715-700 | 700(28") | 740(29.13") | 878(34.57") | 862 (33.94") | 898(35.35") | 439(17.28") | 431(16.97") | — | |
| 539-814 / AT715-750 | 750(30") | 780(30.71") | 918(36.14") | 902 (35.51") | 938(36.93") | 459(18.07") | 451(17.76") | — | |
| 539-815 / AT715-800 | 800(32") | 840(33.07") | 978(38.50") | 962 (37.87") | 998(39.29") | 489(19.25") | 481(18.94") | — | |
| 539-816 / AT715-900 | 900(36") | 940(37.01") | 1078(42.44") | 1062 (41.81") | 1098(43.23") | 539(21.22") | 531(20.91") | — | |
| 539-817 / AT715-1000 | 1000(40") | 1040(40.94") | 1178(46.38") | 1162 (45.75") | 1198(47.17") | 589(23.19") | 581(22.87") | — | |
| 539-818 / AT715-1100 | 1100(44") | 1140(44.88") | 1278(50.31") | 1262 (49.69") | 1298(51.10") | 639(25.16") | 631(24.87") | 430(16.93") | |
| 539-819 / AT715-1200 | 1200(48") | 1240(48.82") | 1378(54.25") | 1362 (53.62") | 1398(55.04") | 689(27.13") | 681(26.82") | 460(18.11") | |
| 539-820 / AT715-1300 | 1300(52") | 1340(52.76") | 1478(58.19") | 1462 (57.56") | 1498(58.98") | 739(29.09") | 731(28.77") | 490(19.29") | |
| 539-821 / AT715-1400 | 1400(56") | 1440(56.69") | 1578(62.13") | 1562 (61.50") | 1598(62.91") | 789(31.06") | 781(30.75") | 520(20.47") | |
| 539-822 / AT715-1500 | 1500(60") | 1540(60.63") | 1678(66.06") | 1662 (65.43") | 1698(66.85") | 839(33.03") | 831(32.72") | 550(21.65") | |
| 539-823 / AT715-1600 | 1600(64") | 1640(64.57") | 1778(70.00") | 1762 (69.37") | 1798(70.79") | 889(35.00") | 881(34.70") | 580(22.83") | |
| 539-824 / AT715-1700 | 1700(68") | 1740(68.50") | 1878(73.94") | 1862 (73.31") | 1898(74.72") | 939(36.97") | 931(36.68") | 610(23.99") | |
| 539-825 / AT715-1800 | 1800(72") | 1840(72.44") | 1978(77.87") | 1962 (77.24") | 1998(78.66") | 989(38.94") | 981(38.65") | 640(25.19") | |
| 539-860 / AT715-2000 | 2000(80") | 2040(80.31") | 2178(85.75") | 2162 (85.12") | 2198(86.54") | 1039(40.91") | 1031(40.58") | 670(26.38") | |
| 539-861 / AT715-2200 | 2200(88") | 2240(88.19") | 2378(93.62") | 2362 (92.99") | 2398(94.41") | 1089(42.87") | 1081(42.54") | 700(27.56") | |
| 539-862 / AT715-2400 | 2400(96") | 2440(96.06") | 2578(101.50") | 2562 (100.87") | 2598(102.28") | 1139(44.83") | 1131(44.51") | 730(28.74") | |
| 539-863 / AT715-2500 | 2500(100") | 2540(100.00") | 2678(105.43") | 2662 (104.80") | 2698(106.22") | 1189(46.80") | 1181(46.50") | 760(29.91") | |
| 539-864 / AT715-2600 | 2600(104") | 2640(103.94") | 2778(109.37") | 2762 (108.74") | 2798(110.16") | 1239(48.76") | 1231(48.46") | 790(31.09") | |
| 539-865 / AT715-2800 | 2800(112") | 2840(111.81") | 2978(117.24") | 2962 (116.61") | 2998(118.03") | 1289(50.73") | 1281(50.43") | 820(32.27") | |
| 539-866 / AT715-3000 | 3000(120") | 3040(119.68") | 3178(125.12") | 3162 (124.49") | 3198(125.91") | 1339(52.70") | 1331(52.39") | 850(33.46") | |

*1: Signal cable length is the combination of built-in signal cable and extension cable (2m).

AT103, Standard-size Type

- Resolution: down to .000005" (5µm)/0.1µm

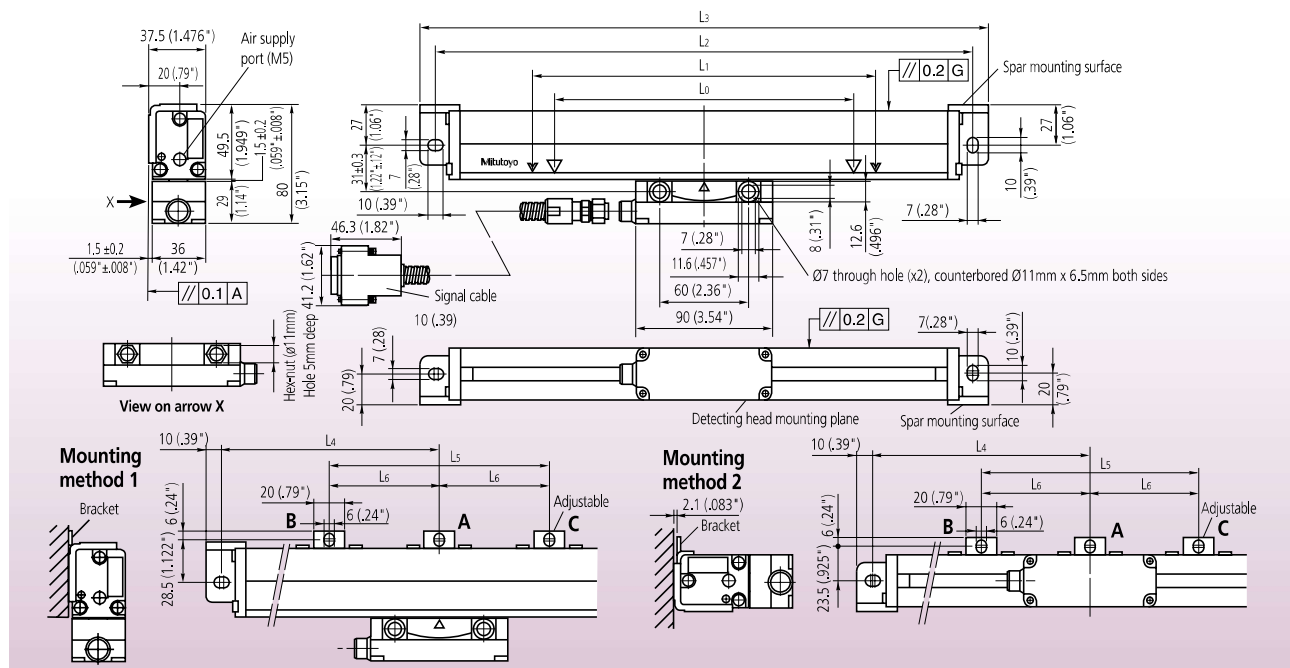

Order No. and mounting dimensions

mm (inch)

| Order No. / Model No. () : suffix for high-accuracy type | Effective range L ₀ | Travel range L ₁ | Mount interval L ₂ | Overall length L ₃ | Supporting bracket position | | | Signal cable length | Mass kg (lbs.) |
|--|--------------------------------|-----------------------------|-------------------------------|-------------------------------|-----------------------------|----------------|----------------|---------------------|----------------|
| | | | | | L ₄ | L ₅ | L ₆ | | |
| 539-111-30 (-40) / AT103-100 (F) | 100 (4") | 120 (4.72") | 248 (9.76") | 268 (10.55") | — | — | — | 3m (9.8 feet) | 1.5 (3.30) |
| 539-112-30 (-40) / AT103-150 (F) | 150 (6") | 170 (6.69") | 298 (11.73") | 318 (12.52") | — | — | — | 3m (9.8 feet) | 1.6 (3.52) |
| 539-113-30 (-40) / AT103-200 (F) | 200 (8") | 220 (8.66") | 348 (13.70") | 368 (14.49") | — | — | — | 3m (9.8 feet) | 1.7 (3.74) |
| 539-114-30 (-40) / AT103-250 (F) | 250 (10") | 270 (10.63") | 398 (15.67") | 418 (16.46") | — | — | — | 3m (9.8 feet) | 1.8 (3.96) |
| 539-115-30 (-40) / AT103-300 (F) | 300 (12") | 330 (12.99") | 458 (18.03") | 478 (18.82") | — | — | — | 3m (9.8 feet) | 1.9 (4.18) |
| 539-116-30 (-40) / AT103-350 (F) | 350 (14") | 380 (14.96") | 508 (20.00") | 528 (20.79") | — | — | — | 3m (9.8 feet) | 2.0 (4.40) |
| 539-117-30 (-40) / AT103-400 (F) | 400 (16") | 430 (16.93") | 558 (21.97") | 578 (22.76") | — | — | — | 3m (9.8 feet) | 2.1 (4.62) |
| 539-118-30 (-40) / AT103-450 (F) | 450 (18") | 480 (18.90") | 608 (23.94") | 628 (24.72") | — | — | — | 3m (9.8 feet) | 2.2 (4.84) |
| 539-119-30 (-40) / AT103-500 (F) | 500 (20") | 540 (21.26") | 668 (26.30") | 688 (27.09") | — | — | — | 3m (9.8 feet) | 2.3 (5.06) |
| 539-121-30 (-40) / AT103-600 (F) | 600 (24") | 650 (25.59") | 778 (30.63") | 798 (31.42") | — | — | — | 3m (9.8 feet) | 2.6 (5.72) |
| 539-123-30 (-40) / AT103-700 (F) | 700 (28") | 760 (29.92") | 888 (34.96") | 908 (35.75") | — | — | — | 3m (9.8 feet) | 2.8 (6.16) |
| 539-124-30 (-40) / AT103-750 (F) | 750 (30") | 810 (31.89") | 938 (36.93") | 958 (37.72") | — | — | — | 3m (9.8 feet) | 2.9 (6.38) |
| 539-125-30 (-40) / AT103-800 (F) | 800 (32") | 860 (33.86") | 988 (38.90") | 1008 (39.69") | — | — | — | 3m (9.8 feet) | 3.0 (6.60) |
| 539-126-30 (-40) / AT103-900 (F) | 900 (36") | 960 (37.79") | 1088 (42.83") | 1108 (43.62") | — | — | — | 3m (9.8 feet) | 3.3 (7.26) |
| 539-127-30 (-40) / AT103-1000 (F) | 1000 (40") | 1060 (41.73") | 1188 (46.77") | 1208 (47.56") | 594 (23.39") | — | — | 5m (16.4 feet) | 3.7 (8.14) |
| 539-128-30 (-40) / AT103-1100 (F) | 1100 (44") | 1160 (45.67") | 1288 (50.71") | 1308 (51.50") | 644 (25.35") | — | — | 5m (16.4 feet) | 4.0 (8.80) |
| 539-129-30 (-40) / AT103-1200 (F) | 1200 (48") | 1260 (49.60") | 1388 (54.65") | 1408 (55.43") | 694 (27.32") | — | — | 5m (16.4 feet) | 4.2 (9.24) |
| 539-130-30 (-40) / AT103-1300 (F) | 1300 (52") | 1360 (53.54") | 1488 (58.58") | 1508 (59.37") | 744 (29.29") | — | — | 5m (16.4 feet) | 4.4 (9.68) |
| 539-131-30 (-40) / AT103-1400 (F) | 1400 (56") | 1460 (57.48") | 1588 (62.52") | 1608 (63.31") | 794 (31.26") | — | — | 5m (16.4 feet) | 4.6 (10.12) |
| 539-132-30 (-40) / AT103-1500 (F) | 1500 (60") | 1560 (61.41") | 1688 (66.46") | 1708 (67.24") | 844 (33.23") | — | — | 5m (16.4 feet) | 4.8 (10.56) |
| 539-133-30 (-40) / AT103-1600 (F) | 1600 (64") | 1690 (66.53") | 1818 (71.57") | 1838 (72.36") | — | 610 (24.02") | — | 5m (16.4 feet) | 5.1 (11.22) |
| 539-134-30 (-40) / AT103-1700 (F) | 1700 (68") | 1790 (70.47") | 1918 (75.51") | 1938 (76.30") | — | 650 (25.59") | — | 5m (16.4 feet) | 5.3 (11.66) |
| 539-135-30 (-40) / AT103-1800 (F) | 1800 (72") | 1890 (74.41") | 2018 (79.45") | 2038 (80.24") | — | 670 (26.38") | — | 5m (16.4 feet) | 5.5 (12.10) |
| 539-136-30 (-40) / AT103-2000 (F) | 2000 (80") | 2100 (82.67") | 2228 (87.72") | 2248 (88.50") | — | 740 (29.13") | — | 5m (16.4 feet) | 6.0 (13.20) |
| 539-137-30 / AT103-2200 | 2200 (88") | 2300 (90.55") | 2428 (95.59") | 2448 (96.38") | — | 800 (31.50") | — | 5m (16.4 feet) | 6.4 (14.08) |
| 539-138-30 / AT103-2400 | 2400 (96") | 2500 (98.42") | 2628 (103.46") | 2648 (104.25") | 1314 (51.73") | 1300 (51.18") | 650 (25.59") | 7m (22.9 feet) | 7.1 (15.62) |
| 539-139-30 / AT103-2500 | 2500 (100") | 2600 (102.36") | 2728 (107.40") | 2748 (108.19") | 1364 (53.70") | 1340 (52.76") | 670 (25.38") | 7m (22.9 feet) | 7.3 (16.06) |
| 539-140-30 / AT103-2600 | 2600 (104") | 2700 (106.30") | 2828 (111.34") | 2848 (112.13") | 1414 (55.67") | 1400 (55.12") | 700 (27.56") | 7m (22.9 feet) | 7.5 (16.50) |
| 539-141-30 / AT103-2800 | 2800 (112") | 2900 (114.17") | 3028 (119.21") | 3048 (120.00") | 1514 (59.60") | 1500 (59.06") | 750 (29.53") | 7m (22.9 feet) | 7.9 (17.38) |
| 539-142-30 / AT103-3000 | 3000 (122") | 3100 (122.04") | 3228 (127.09") | 3248 (127.87") | 1614 (63.99") | 1600 (62.99") | 800 (31.50") | 7m (22.9 feet) | 8.3 (18.26) |

Note When selecting the size of a scale unit for your application, make sure that the maximum travel range of the scale unit (L₁) is larger than the maximum travel range of the machine. Also, take into consideration selecting a size that the accuracy of the scale unit is guaranteed only within the range of the effective measuring length (L₀).

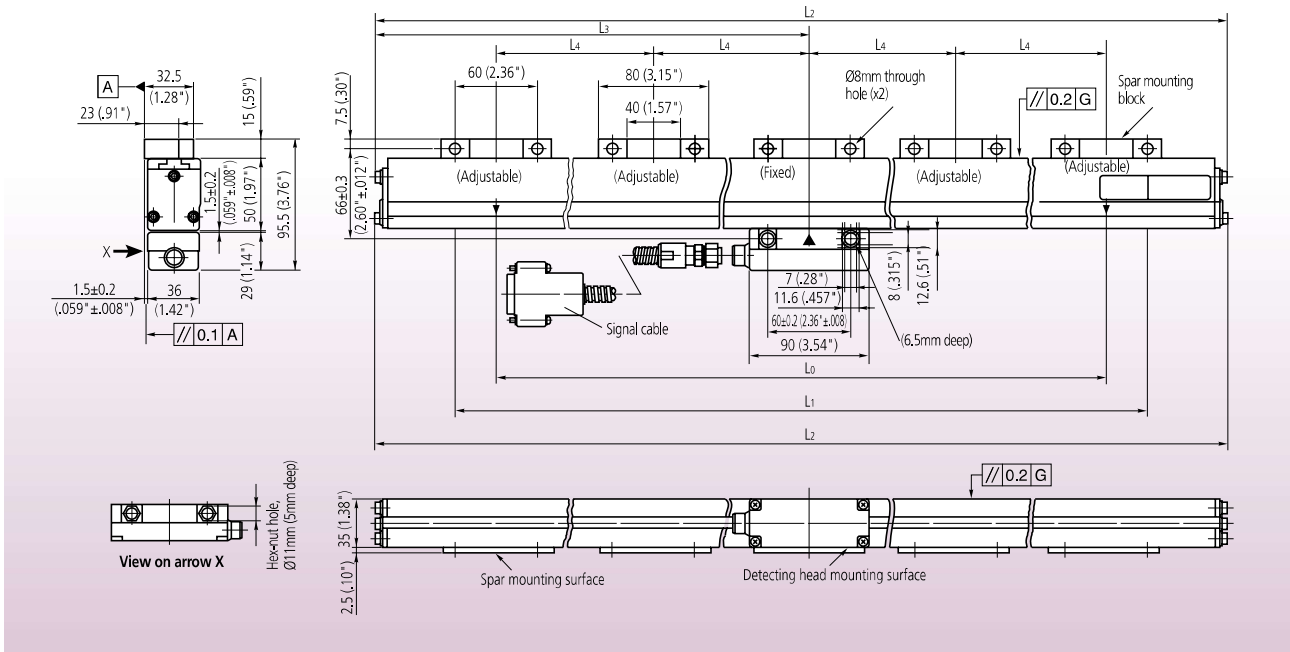

Order No. and mounting dimensions

mm (inch)

| Order No. / Model No. | Effective range L ₀ | Travel range L ₁ | Overall length L ₂ | Supporting bracket position L ₃ | Signal cable length L ₄ | Mass (kg (lbs.)) |
|-------------------------|--------------------------------|-----------------------------|-------------------------------|--|------------------------------------|------------------|
| 539-143-30 / AT103-3250 | 3250 (130") | 3350 (131.88") | 3464 (136.38") | 1725 (67.91") | 800 (31.50") | 10.8 (23.76) |
| 539-144-30 / AT103-3500 | 3500 (140") | 3600 (141.73") | 3714 (146.22") | 1850 (72.83") | 850 (33.46") | 11.4 (25.08) |
| 539-145-30 / AT103-3750 | 3750 (150") | 3850 (151.57") | 3964 (156.06") | 1975 (77.76") | 930 (36.61") | 12.0 (26.40) |
| 539-146-30 / AT103-4000 | 4000 (160") | 4100 (161.42") | 4214 (165.91") | 2100 (82.68") | 1000 (39.37") | 12.6 (27.72) |
| 539-147-30 / AT103-4250 | 4250 (170") | 4350 (171.26") | 4464 (175.75") | 2225 (87.60") | 1050 (41.34") | 13.2 (29.04) |
| 539-148-30 / AT103-4500 | 4500 (180") | 4600 (181.10") | 4714 (185.59") | 2350 (92.52") | 1100 (43.31") | 13.8 (30.36) |
| 539-149-30 / AT103-4750 | 4750 (190") | 4850 (191.94") | 4964 (195.43") | 2475 (97.44") | 800 (31.50") | 15.2 (33.44) |
| 539-150-30 / AT103-5000 | 5000 (200") | 5100 (200.78") | 5214 (205.28") | 2600 (102.36") | 830 (32.68") | 15.8 (34.76) |
| 539-151-30 / AT103-5250 | 5250 (210") | 5350 (210.63") | 5464 (215.12") | 2725 (107.28") | 870 (34.25") | 16.4 (36.08) |
| 539-152-30 / AT103-5500 | 5500 (220") | 5600 (220.47") | 5714 (224.96") | 2850 (112.20") | 910 (35.83") | 17.0 (37.40) |
| 539-153-30 / AT103-5750 | 5750 (230") | 5850 (230.31") | 5964 (234.80") | 2975 (117.13") | 950 (37.40") | 17.6 (38.72) |
| 539-154-30 / AT103-6000 | 6000 (240") | 6100 (240.16") | 6214 (244.65") | 3100 (122.05") | 1000 (39.37") | 18.2 (40.04) |

Note) When selecting the size of a scale unit for your application, make sure that the maximum travel range of the scale unit (L₁) is larger than the maximum travel range of the machine. Also, take into consideration in selecting a size that the accuracy of the scale unit is guaranteed only within the range of the effective measuring length (L₀).

Extension cables

| Order No. | Cable length |
|-----------|----------------|
| 09AAA033A | 2m (6.5 feet) |
| 09AAA033B | 5m (16.4 feet) |
| 09AAA033C | 7m (22.9 feet) |



Mounting parts (provided as standard)

| Type of spar | Standard size | Extra-long |
|--------------------------------|---|--|
| Effective range L ₀ | 100mm (4") - 3000mm (120") | 3250mm (130") - 6000mm (240") |
| Items included | <ul style="list-style-type: none"> Hex-socket head screw (M6x1x40) 2 pcs. Hex-socket head screw (M6x1x16) 2 pcs. Hex-socket head screw (M4x0.7x8) 6 pcs. Spring washer (6mm nominal) 2 pcs. Plain washer (6mm nominal) 2 pcs. Cable clip 5 pcs. Spacer (0.3mm) 1 pc. Spacer (0.4mm) 1 pc. Spacer (0.5mm) 1 pc. Spacer (0.6mm) 1 pc. | <ul style="list-style-type: none"> Hex-socket head screw (M6x1x40) 2 pcs. Hex-socket head screw (M6x1x30) 14 pcs. Hex-socket head screw (M4x0.7x8) 7 pcs. Spring washer (6mm nominal) 14 pcs. Plain washer (6mm nominal) 14 pcs. Cable clip 7 pcs. Spacer (0.3mm) 1 pc. Spacer (0.4mm) 1 pc. Spacer (0.5mm) 1 pc. Spacer (0.6mm) 1 pc. |

Remarks: Dust-proofing and splash-proofing of the AT103 model scale units can be improved by supplying clean and dry air to the main spar. (Air pressure required: 50kPa, Air flow rate: 10 to 20 liters per minute)

AT113, Slim Type

- Resolution: down to .000005" (5µin)/0.1µm

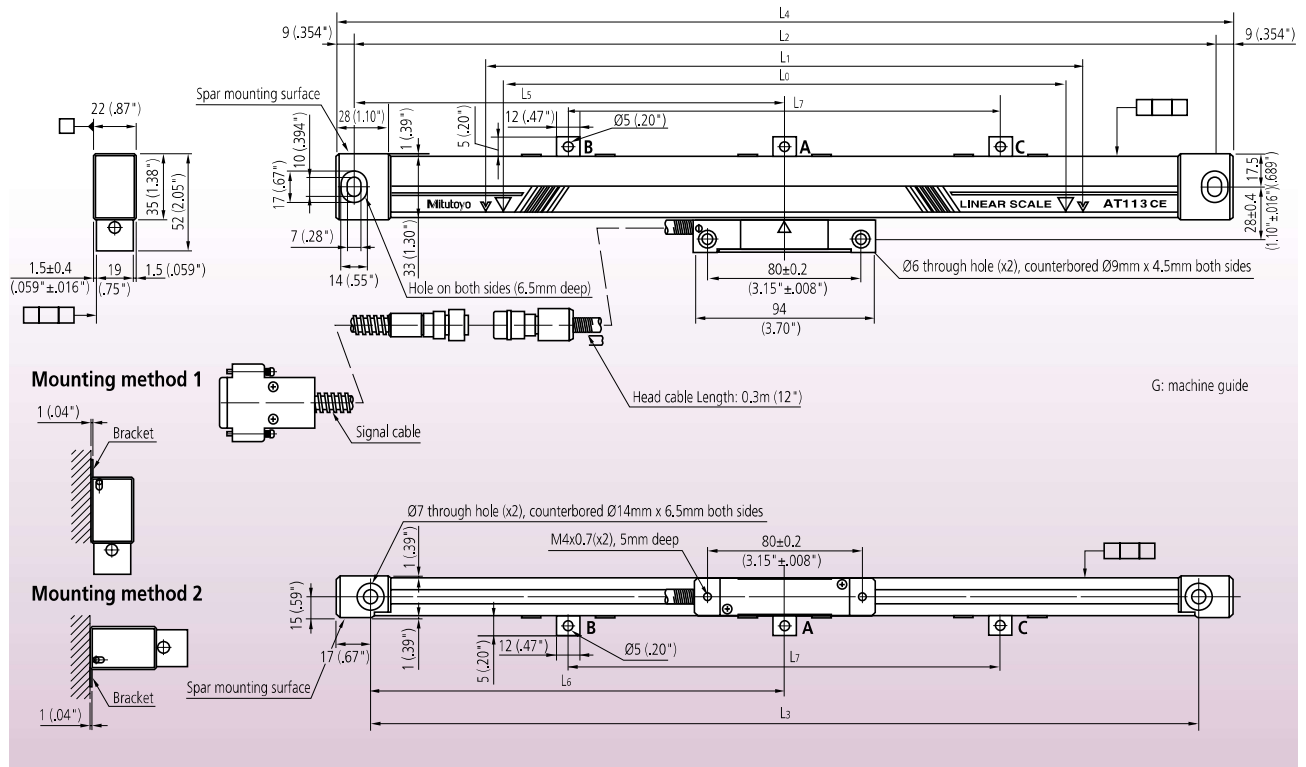

Order No. and mounting dimensions

| Order No. / Model No. (): suffix for high accuracy type | Effective range L ₀ | Travel range L ₁ | Mount interval L ₂ | Mount interval L ₃ | Overall length L ₄ | Supporting bracket position | | | Signal cable length | Mass kg (lbs.) |
|---|--------------------------------|-----------------------------|-------------------------------|-------------------------------|-------------------------------|-----------------------------|----------------|----------------|---------------------|----------------|
| | | | | | | L ₅ | L ₆ | L ₇ | | |
| 539-201-30 (-40) / AT113-100 (F) | 100 (4") | 120 (4.72") | 258 (10.16") | 242 (9.53") | 276 (10.87") | — | — | — | 3m (9.8 feet) | 0.9 (1.98) |
| 539-202-30 (-40) / AT113-150 (F) | 150 (6") | 170 (6.69") | 308 (12.13") | 292 (11.50") | 326 (12.83") | — | — | — | 3m (9.8 feet) | 0.9 (1.98) |
| 539-203-30 (-40) / AT113-200 (F) | 200 (8") | 220 (8.66") | 358 (14.09") | 342 (13.46") | 376 (14.80") | — | — | — | 3m (9.8 feet) | 0.9 (1.98) |
| 539-204-30 (-40) / AT113-250 (F) | 250 (10") | 270 (10.63") | 408 (16.06") | 392 (15.43") | 426 (16.77") | — | — | — | 3m (9.8 feet) | 1.0 (2.2) |
| 539-205-30 (-40) / AT113-300 (F) | 300 (12") | 330 (12.99") | 468 (18.43") | 452 (17.80") | 486 (19.13") | — | — | — | 3m (9.8 feet) | 1.0 (2.2) |
| 539-206-30 (-40) / AT113-350 (F) | 350 (14") | 380 (14.96") | 518 (20.39") | 502 (19.76") | 536 (21.10") | — | — | — | 3m (9.8 feet) | 1.1 (2.42) |
| 539-207-30 (-40) / AT113-400 (F) | 400 (16") | 430 (16.93") | 568 (22.36") | 552 (21.73") | 586 (23.07") | — | — | — | 3m (9.8 feet) | 1.1 (2.42) |
| 539-208-30 (-40) / AT113-450 (F) | 450 (18") | 480 (18.90") | 618 (24.33") | 602 (23.70") | 636 (25.04") | — | — | — | 3m (9.8 feet) | 1.1 (2.42) |
| 539-209-30 (-40) / AT113-500 (F) | 500 (20") | 540 (21.26") | 678 (26.69") | 662 (26.06") | 696 (27.40") | 339 (13.35") | 331 (13.03") | — | 3m (9.8 feet) | 1.2 (2.64) |
| 539-211-30 (-40) / AT113-600 (F) | 600 (24") | 640 (25.20") | 778 (30.63") | 762 (30.00") | 796 (31.34") | 389 (15.31") | 381 (15.00") | — | 3m (9.8 feet) | 1.3 (2.86) |
| 539-213-30 (-40) / AT113-700 (F) | 700 (28") | 740 (29.13") | 878 (34.57") | 862 (33.94") | 896 (35.28") | 439 (17.28") | 431 (16.97") | — | 3m (9.8 feet) | 1.3 (2.86) |
| 539-214-30 (-40) / AT113-750 (F) | 750 (30") | 780 (30.71") | 918 (36.14") | 902 (35.51") | 936 (36.85") | 459 (18.07") | 451 (17.76") | — | 3m (9.8 feet) | 1.4 (3.08) |
| 539-215-30 (-40) / AT113-800 (F) | 800 (32") | 840 (33.07") | 978 (38.50") | 962 (37.87") | 996 (39.21") | 489 (19.25") | 481 (18.94") | — | 3m (9.8 feet) | 1.4 (3.08) |
| 539-216-30 (-40) / AT113-900 (F) | 900 (36") | 940 (37.01") | 1078 (42.44") | 1062 (41.81") | 1096 (43.15") | 539 (21.22") | 531 (20.91") | — | 3m (9.8 feet) | 1.5 (3.3) |
| 539-217-30 (-40) / AT113-1000 (F) | 1000 (40") | 1040 (40.94") | 1178 (46.38") | 1162 (45.75") | 1196 (47.09") | 589 (23.19") | 581 (22.87") | — | 5m (16.4 feet) | 1.9 (4.18) |
| 539-218-30 (-40) / AT113-1100 (F) | 1100 (44") | 1140 (44.88") | 1278 (50.31") | 1262 (49.69") | 1296 (51.02") | — | — | 430 (16.93") | 5m (16.4 feet) | 1.9 (4.18) |
| 539-219-30 (-40) / AT113-1200 (F) | 1200 (48") | 1240 (48.82") | 1378 (54.25") | 1362 (53.62") | 1396 (54.96") | — | — | 460 (18.11") | 5m (16.4 feet) | 2.0 (4.4) |
| 539-220-30 (-40) / AT113-1300 (F) | 1300 (52") | 1340 (52.76") | 1478 (58.19") | 1462 (57.56") | 1496 (58.90") | — | — | 490 (19.29") | 5m (16.4 feet) | 2.1 (4.62) |
| 539-221-30 (-40) / AT113-1400 (F) | 1400 (56") | 1440 (56.69") | 1578 (62.13") | 1562 (61.50") | 1596 (62.83") | — | — | 530 (20.87") | 5m (16.4 feet) | 2.2 (4.84) |
| 539-222-30 (-40) / AT113-1500 (F) | 1500 (60") | 1540 (60.63") | 1678 (66.06") | 1662 (65.43") | 1696 (66.77") | — | — | 560 (22.05") | 5m (16.4 feet) | 2.2 (4.84) |

Note) When selecting the size of a scale unit for your application, make sure that the maximum travel range of the scale unit (L₁) is larger than the maximum travel range of the machine. Also, take into consideration in selecting a size that the accuracy of the scale unit is guaranteed only within the range of the effective measuring length (L₀).

Extension cables

| Order No. | Cable length |
|-----------|----------------|
| 09AAA033A | 2m (6.5 feet) |
| 09AAA033B | 5m (16.4 feet) |
| 09AAA033C | 7m (22.9 feet) |

Mounting parts (provided as standard)

| Items included | | |
|-----------------------------------|--------|--|
| Hex-socket head screw (M6x1x25) | 2 pcs. | |
| Hex-socket head screw (M4x0.7x25) | 2 pcs. | |
| Hex-socket head screw (M4x0.7x8) | 6 pcs. | |
| Spring washer (4mm nominal) | 2 pcs. | |
| Plain washer (4mm nominal) | 2 pcs. | |
| Cable clip | 5 pcs. | |
| Connector clamp | 1 pc. | |
| Spacer (0.3mm) | 1 pc. | |
| Spacer (0.4mm) | 1 pc. | |
| Spacer (0.5mm) | 1 pc. | |
| Spacer (0.6mm) | 1 pc. | |

AT116, Slim and Economy Type

- Resolution: down to .000005" (5µin)/0.1µm

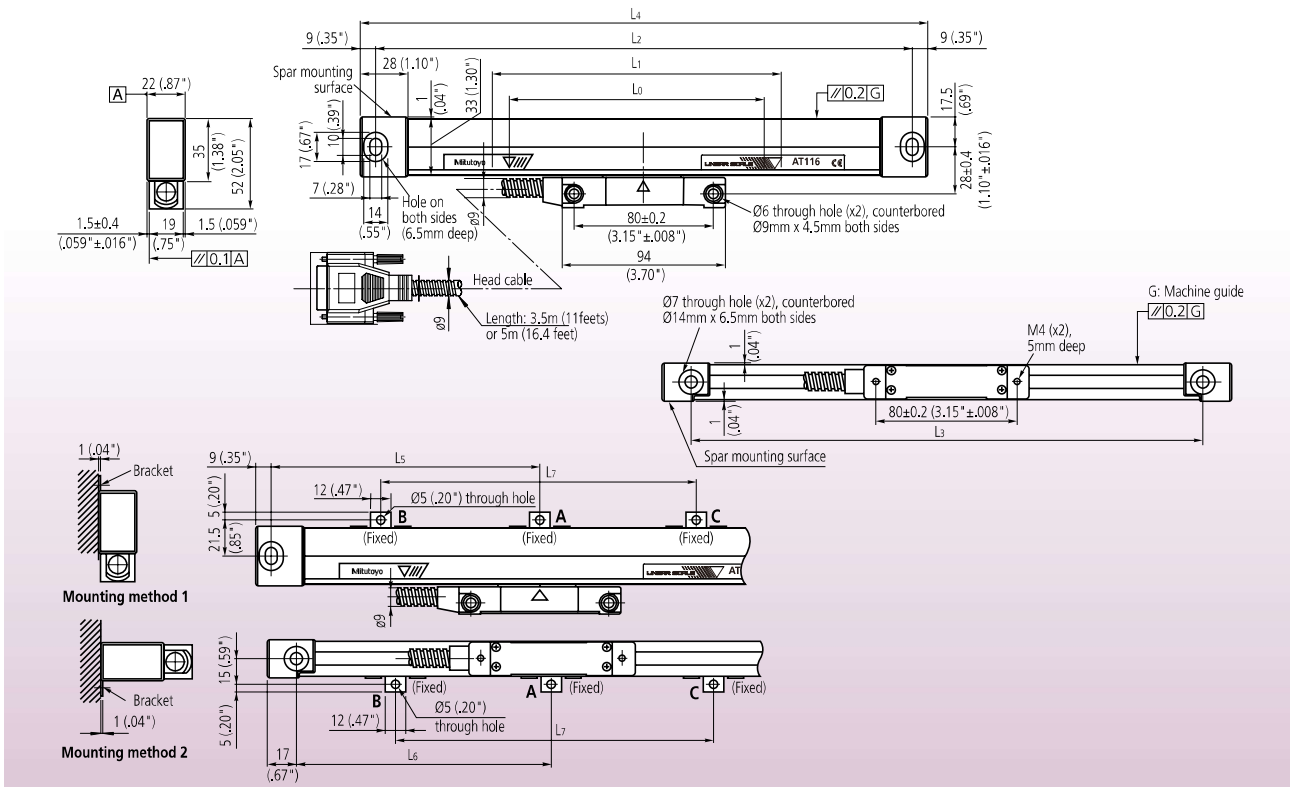

Order No. and mounting dimensions

mm (inch)

| Order No. / Model No. | Effective range L ₀ | Travel range L ₁ | Mount interval L ₂ | Mount interval L ₃ | Overall length L ₄ | Supporting bracket position | | | Head cable length | Mass kg (lbs.) |
|--------------------------|--------------------------------|-----------------------------|-------------------------------|-------------------------------|-------------------------------|-----------------------------|----------------|----------------|-------------------|----------------|
| | | | | | | L ₅ | L ₆ | L ₇ | | |
| 539-271-30 / AT-116-100 | 100 (4") | 120 (4.72") | 258 (10.16") | 242 (9.53") | 276 (10.87") | — | — | — | 3.5m (9.8 feet) | 0.5 (1.1) |
| 539-272-30 / AT-116-150 | 150 (6") | 170 (6.69") | 308 (12.13") | 292 (11.50") | 326 (12.83") | — | — | — | 3.5m (9.8 feet) | 0.6 (1.32) |
| 539-273-30 / AT-116-200 | 200 (8") | 220 (8.66") | 358 (14.09") | 342 (13.46") | 376 (14.80") | — | — | — | 3.5m (9.8 feet) | 0.7 (1.54) |
| 539-274-30 / AT-116-250 | 250 (10") | 270 (10.63") | 408 (16.06") | 392 (15.43") | 426 (16.77") | — | — | — | 3.5m (9.8 feet) | 0.8 (1.76) |
| 539-275-30 / AT-116-300 | 300 (12") | 330 (12.99") | 468 (18.43") | 452 (17.80") | 486 (19.13") | — | — | — | 3.5m (9.8 feet) | 0.9 (1.98) |
| 539-276-30 / AT-116-350 | 350 (14") | 380 (14.96") | 518 (20.39") | 502 (19.76") | 536 (21.10") | — | — | — | 3.5m (9.8 feet) | 1.0 (2.2) |
| 539-277-30 / AT-116-400 | 400 (16") | 430 (16.93") | 568 (22.36") | 552 (21.73") | 586 (23.07") | — | — | — | 3.5m (9.8 feet) | 1.1 (2.42) |
| 539-278-30 / AT-116-450 | 450 (18") | 480 (18.90") | 618 (24.33") | 602 (23.70") | 636 (25.04") | — | — | — | 3.5m (9.8 feet) | 1.2 (2.64) |
| 539-279-30 / AT-116-500 | 500 (20") | 540 (21.26") | 678 (26.69") | 662 (26.06") | 696 (27.40") | 339 (13.35") | 331 (13.03") | — | 3.5m (9.8 feet) | 1.3 (2.86) |
| 539-281-30 / AT-116-600 | 600 (24") | 640 (25.20") | 778 (30.63") | 762 (30.00") | 796 (31.34") | 389 (15.31") | 381 (15.00") | — | 3.5m (9.8 feet) | 1.4 (3.08) |
| 539-283-30 / AT-116-700 | 700 (28") | 740 (29.13") | 878 (34.57") | 862 (33.94") | 896 (35.28") | 439 (17.28") | 431 (16.97") | — | 3.5m (9.8 feet) | 1.6 (3.52) |
| 539-284-30 / AT-116-750 | 750 (30") | 780 (30.71") | 918 (36.14") | 902 (35.51") | 936 (36.85") | 459 (18.07") | 451 (17.76") | — | 3.5m (9.8 feet) | 1.7 (3.74) |
| 539-285-30 / AT-116-800 | 800 (32") | 840 (33.07") | 978 (38.50") | 962 (37.87") | 996 (39.21") | 489 (19.25") | 481 (18.94") | — | 3.5m (9.8 feet) | 1.8 (3.96) |
| 539-286-30 / AT-116-900 | 900 (36") | 940 (37.01") | 1078 (42.44") | 1062 (41.81") | 1096 (43.15") | 539 (21.22") | 531 (20.91") | — | 3.5m (9.8 feet) | 2.0 (4.4) |
| 539-287-30 / AT-116-1000 | 1000 (40") | 1040 (40.94") | 1178 (46.38") | 1162 (45.75") | 1196 (47.09") | 589 (23.19") | 581 (22.87") | — | 5m (16.4 feet) | 2.3 (5.06) |
| 539-288-30 / AT-116-1100 | 1100 (44") | 1140 (44.88") | 1278 (50.31") | 1262 (49.69") | 1296 (51.02") | — | — | 430 (16.93") | 5m (16.4 feet) | 2.5 (5.5) |
| 539-289-30 / AT-116-1200 | 1200 (48") | 1240 (48.82") | 1378 (54.25") | 1362 (53.62") | 1396 (54.96") | — | — | 460 (18.11") | 5m (16.4 feet) | 2.7 (5.94) |
| 539-290-30 / AT-116-1300 | 1300 (52") | 1340 (52.76") | 1478 (58.19") | 1462 (57.56") | 1496 (58.90") | — | — | 490 (19.29") | 5m (16.4 feet) | 2.9 (6.38) |
| 539-291-30 / AT-116-1400 | 1400 (56") | 1440 (56.69") | 1578 (62.13") | 1562 (61.50") | 1596 (62.83") | — | — | 530 (20.87") | 5m (16.4 feet) | 3.1 (6.82) |
| 539-292-30 / AT-116-1500 | 1500 (60") | 1540 (60.63") | 1678 (66.06") | 1662 (65.43") | 1696 (66.77") | — | — | 560 (22.05") | 5m (16.4 feet) | 3.2 (7.04) |

Note) When selecting the size of a scale unit for your application, make sure that the maximum travel range of the scale unit (L₁) is larger than the maximum travel range of the machine. Also, take into consideration in selecting a size that the accuracy of the scale unit is guaranteed only within the range of the effective measuring length (L₀).



Extension cables

| Order No. | Cable length |
|-----------|----------------|
| 09AAB674A | 2m (6.5 feet) |
| 09AAB674B | 5m (16.4 feet) |
| 09AAB674C | 7m (22.9 feet) |

Mounting parts (provided as standard)

| Items included | Quantity |
|-------------------------------------|----------|
| • Hex-socket head screw (M6x1x25) | 2 pcs. |
| • Hex-socket head screw (M4x0.7x25) | 2 pcs. |
| • Hex-socket head screw (M4x0.7x8) | 6 pcs. |
| • Plain washer (6mm nominal) | 2 pcs. |
| • Plain washer (4mm nominal) | 2 pcs. |
| • Connector clamp | 6 pc. |
| • Spacer (0.3mm) | 1 pc. |
| • Spacer (0.4mm) | 1 pc. |
| • Spacer (0.5mm) | 1 pc. |
| • Spacer (0.6mm) | 1 pc. |

AT112-F, Super Slim Type

- Resolution: down to .000005" (5µin)/0.1µm

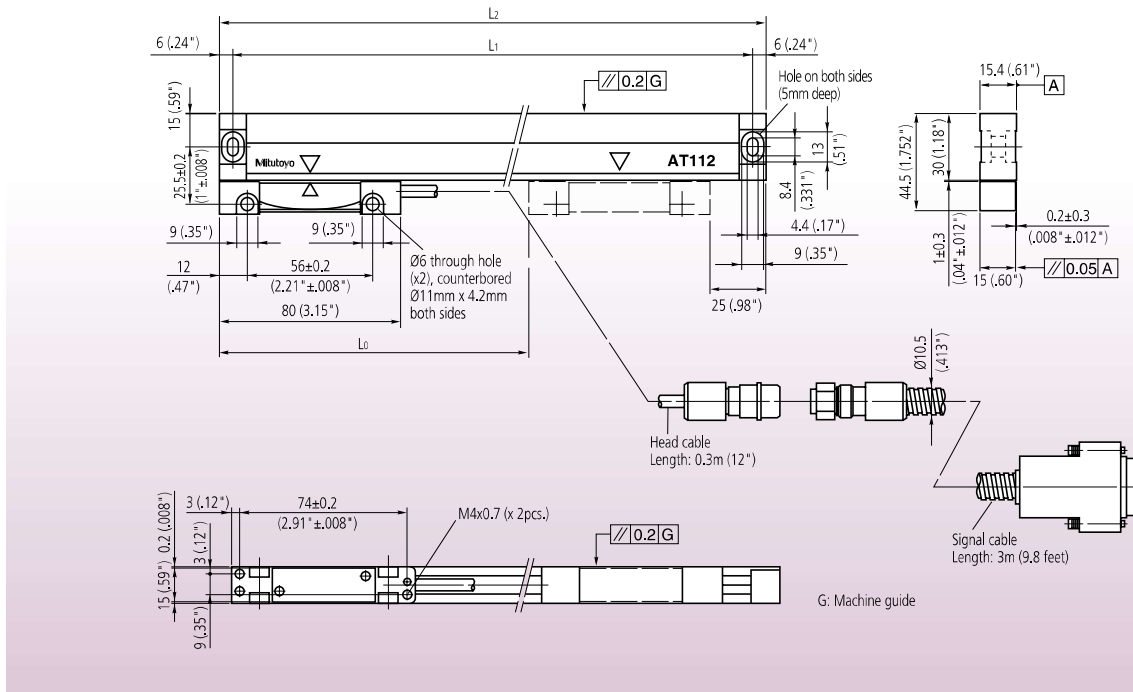

Order No. and mounting dimensions

mm (inch)

| Order No. / Model No. | Effective range L ₀ | Mount interval L ₁ | Overall length L ₂ | Signal cable length | Mass kg (lbs.) |
|--------------------------|--------------------------------|-------------------------------|-------------------------------|---------------------|----------------|
| 539-251-10 / AT112-50F | 50 (2.0") | 143 (5.63") | 155 (6.10") | 3m (9.8 feet) | 0.72 (1.58) |
| 539-252-10 / AT112-70F | 70 (2.8") | 163 (6.42") | 175 (10.89") | 3m (9.8 feet) | 0.74 (1.63) |
| 539-253-10 / AT112-120F | 120 (4.8") | 213 (8.39") | 225 (8.86") | 3m (9.8 feet) | 0.80 (1.76) |
| 539-254-10 / AT112-170F | 170 (6.8") | 263 (10.35") | 275 (10.83") | 3m (9.8 feet) | 0.85 (1.87) |
| 539-255-10 / AT112-220F | 220 (8.8") | 313 (12.32") | 325 (12.80") | 3m (9.8 feet) | 0.90 (1.98) |
| 539-256-10 / AT112-270F | 270 (10.8") | 363 (14.29") | 375 (14.76") | 3m (9.8 feet) | 0.95 (2.09) |
| 539-257-10 / AT112-320F | 320 (12.8") | 413 (16.26") | 425 (16.73") | 3m (9.8 feet) | 1.00 (2.20) |
| 539-258-10 / AT112-370F | 370 (14.8") | 463 (18.23") | 475 (18.70") | 3m (9.8 feet) | 1.05 (2.31) |
| 539-259-10 / AT112-420F | 420 (16.8") | 513 (20.20") | 525 (20.67") | 3m (9.8 feet) | 1.10 (2.42) |
| 539-260-10 / AT112-470F | 470 (18.8") | 563 (22.17") | 575 (22.64") | 3m (9.8 feet) | 1.15 (2.53) |
| 539-261-10 / AT112-520F | 520 (20.8") | 613 (24.13") | 625 (24.61") | 3m (9.8 feet) | 1.20 (2.64) |
| 539-262-10 / AT112-570F | 570 (22.8") | 663 (26.10") | 675 (26.57") | 3m (9.8 feet) | 1.25 (2.75) |
| 539-263-10 / AT112-620F | 620 (24.8") | 713 (28.07") | 725 (28.54") | 3m (9.8 feet) | 1.30 (2.86) |
| 539-264-10 / AT112-670F | 670 (26.8") | 763 (30.04") | 775 (30.51") | 3m (9.8 feet) | 1.35 (2.97) |
| 539-265-10 / AT112-720F | 720 (28.8") | 813 (32.01") | 825 (32.48") | 3m (9.8 feet) | 1.40 (3.08) |
| 539-266-10 / AT112-770F | 770 (30.8") | 863 (33.98") | 875 (34.45") | 3m (9.8 feet) | 1.45 (3.19) |
| 539-267-10 / AT112-820F | 820 (32.8") | 913 (35.94") | 925 (36.42") | 3m (9.8 feet) | 1.50 (3.30) |
| 539-268-10 / AT112-920F | 920 (36.8") | 1013 (39.88") | 1025 (40.35") | 3m (9.8 feet) | 1.56 (3.43) |
| 539-269-10 / AT112-1020F | 1020 (40.8") | 1113 (43.82") | 1125 (44.29") | 3m (9.8 feet) | 1.62 (3.56) |

Note) When selecting the size of a scale unit for your application, make sure that the maximum travel range of the scale unit (L₁) is larger than the maximum travel range of the machine. Also, take into consideration in selecting a size that the accuracy of the scale unit is guaranteed only within the range of the effective measuring length (L₀).

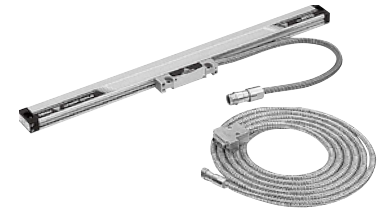

Extension cables

























| Order No. | Cable length |
|-----------|----------------|
| 09AAA033A | 2m (6.5 feet) |
| 09AAA033B | 5m (16.4 feet) |
| 09AAA033C | 7m (22.9 feet) |

Mounting parts (provided as standard)

| Items included | Quantity |
|-------------------------------------|----------|
| • Hex-socket head screw (M4x0.7x25) | 4 pcs. |
| • Hex-socket head screw (M4x0.7x8) | 6 pcs. |
| • Spring washer (4mm nominal) | 4 pcs. |
| • Plain washer (4mm nominal) | 4 pcs. |
| • Cable clip | 5 pcs. |
| • Connector clamp | 1 pc. |
| • Spacer (0.3mm) | 1 pc. |
| • Spacer (0.4mm) | 1 pc. |
| • Spacer (0.5mm) | 1 pc. |
| • Spacer (0.6mm) | 1 pc. |

Display Unit Features

Functions

| Counter | | KA-200 Counter |
|---|---|--|
| Function | |  |
| Zero-setting |  | ● |
| Preset |  | ● |
| Resolution setting |  | ● |
| Measurement direction setting |  | ● |
| mm/inch conversion |  | ● |
| Diameter display |  | ● |
| Scale reference point setting ⁻¹ |  | ● |
| 1/2 calculation |  | ● |
| Coordinate system switching |  | ● |
| Bolt-hole circle machining |  | ● ⁻² |
| Pitch machining |  | ● |
| Zero approach machining (INC mode) |  | ● |
| Addition of 2-scale data |  | ● ⁻³ |
| Linearity error compensation |  | ● |
| Pitch error compensation |  | ● ⁻¹ |
| Smoothing |  | ● |
| Memory backup |  | ● |
| Expansion/contraction coefficient setting |  | — |
| Lower digit blanking out |  | ● |
| External zero-setting |  | ▲ ⁻⁴ |
| RS-232C interface unit |  | ▲ ⁻⁴ |
| USB output |  | ▲ ⁻⁵ |
| Limit signal output |  | — |
| Error message |  | ● |

●: Standard function, ▲: Optional function, —: Not available

-1: Only available when connecting with AT100 series.

-2: Not available in single-axis use

-3: Only available for 3-axis model

-4: Code out unit (06AET993) is required.

-5: Text can be output by interface unit and foot switch

KA-200 Counter

Multiple feature, intuitive display

FEATURES

- Absolute and Incremental modes (9 presets each)
- Calculator function
- Segmented and Linear Error Compensation
- Can be used as a standard counter or a lathe counter by modifying parameters.
- Larger sub display for easy operation.
- Data can be sent directly into spreadsheets using the optional code out unit (09AET993).
- RS-232C data can be output to a PC, printer or PLC using the optional code out unit (09AET993)

Standard Accessories

- 02ZAA010:** 1.8m AC cable (USA, Canada)
- 06AEU075:** Dust-proof cover
- 09CAA985:** GND lead wire (4m)
- 06AEU080:** Seal set (1 pc.)
- 06AFC149:** D-SUB15P Connector cap
- 99MBE083A:** User's Manual (1 set)

Optional Accessories

- 06AET993:** Code out unit
- 937179T:** Foot switch for measurement data output (USB interface)
- 64AAB336:** Foot switch to trigger RS-232C (direct)
- 64AAB519:** RS232C output cable 6-ft. (25-9 pin)
- 965004:** Foot switch to trigger RS-232C (use w/06ACF941)
- 06ACF941:** External extension cable
- 937328:** External load box
- 936553:** External zero box
- 06ACB393:** Adapter for linear gages with origin
- 06ACB913:** Adapter for linear gages without origin
- 06ACB391:** Adapter for AT211 linear scales
- 06ACB392:** Adapter for ST Series
- 09CAB231:** Adapter for micrometer head
- 09AAA207:** Adapter for previous model 6 pin linear scales
- 09EAA094:** Counter cable RS232C for DP-1VA



174-183A (for 1-axis or 2-axis application)

174-185A (for 3-axis application)

DIMENSIONS

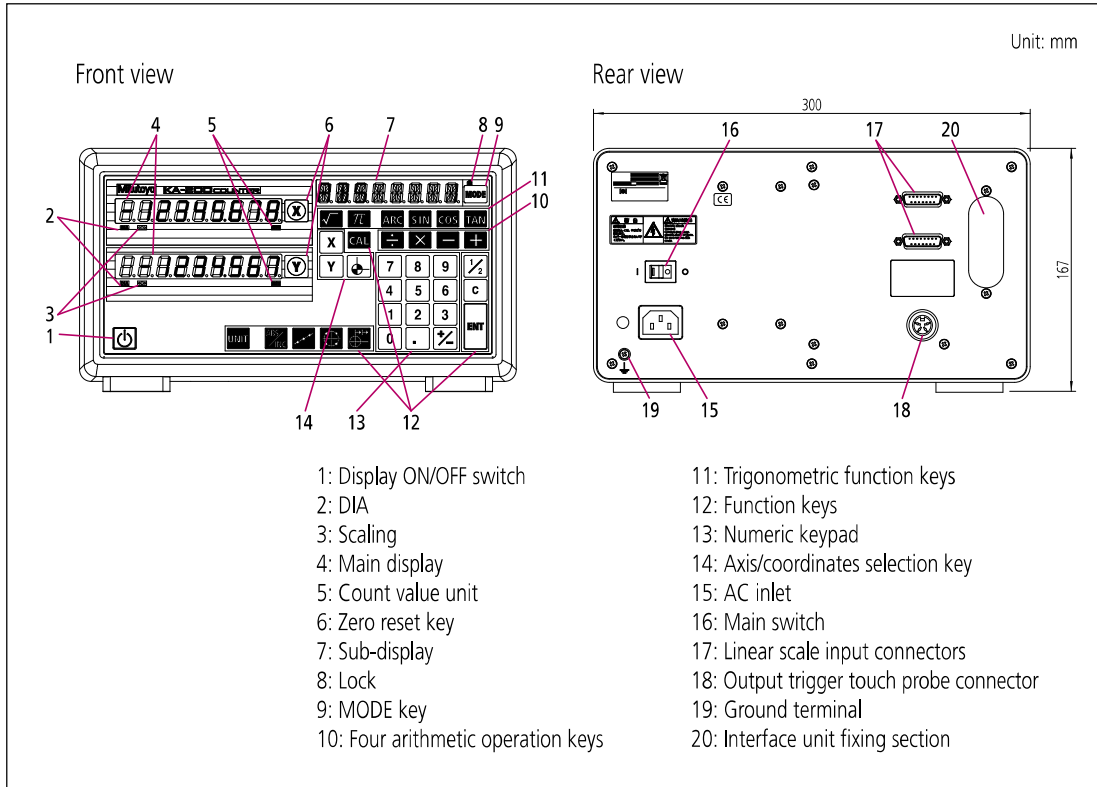

SPECIFICATIONS

| Model | KA-200 Counter | |
|----------------------|---|----------|
| Order No. | 174-183A | 174-185A |
| Resolution | With AT100: .01"-.000005" (0.1-0.0001mm) With AT715: .01"-.000020" (0.1-0.0005mm) | |
| Scale input ports | 2 | 3 |
| Display type / digit | 7-segment, 8-digit + sign + 8-character alphabet LED | |
| Output (optional) | RS-232C / USB | |
| Macro functions | Rectangular drilling and round milling newly added | |
| Main features | Feed speed display; taper machining function; tool data; multipoint compensation; scale check function; calculator function | |
| Dimensions | Size (WxDxH) 30x168x70mm | |

USB Output

A KA-series counter can output measurement values as USB text data in combination with the optional code output unit and foot switch. These numeric values can be imported to applications such as Excel.

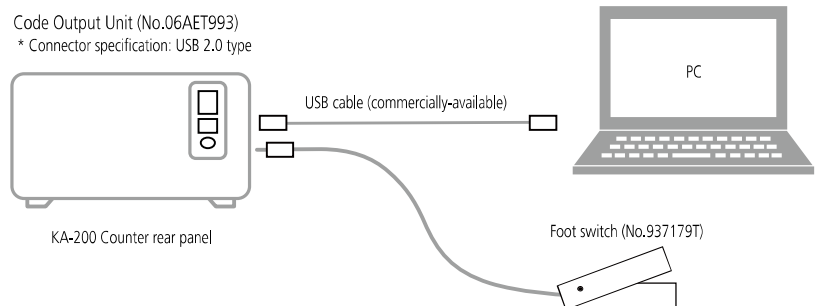

Display Unit Functions

BASIC FUNCTIONS

ZERO Zero-setting

The display can be set to "0" (zero) at any scale position.



P.SET Preset

This function allows the user to enter a numeric value on the counter display. Any preset value can be retrieved whenever necessary.

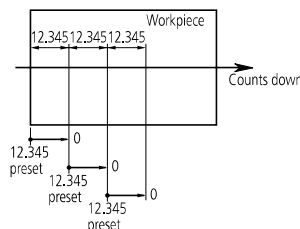

Measurement direction setting

The measurement direction can be selected.

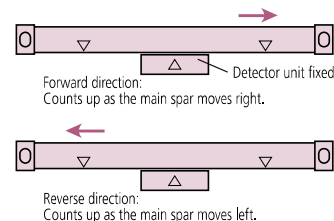

123 45 Lower digit blanking out

Unnecessary lower digits (up to 9 digits of the lowest digits) can be blanked out.

1/2 1/2 calculation

This function halves the display value.

mm/E mm/inch conversion

The counting unit can be changed between mm and inch (or between mm and E (=1/25.4mm) depending on the model.)

0.001 / 0.01 Resolution setting

The most suitable resolution can be selected to meet measuring applications. Available resolutions depend on the counter to be used.

I/A Absolute/incremental coordinate system switching

For each axis, the measured value can be obtained in either absolute (ABS) or incremental (INC) coordinates. This function is useful, for example, if the following operation is performed. Set the datum point for a workpiece in the absolute mode. Then, after performing zero setting, presetting, etc., in the incremental mode, return to the absolute mode. In this way the absolute distance from the datum point can be easily displayed.

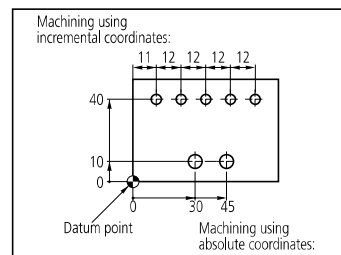

SPECIAL FUNCTIONS

Linear error compensation

Machine errors caused due to workpiece weight, inaccurate table adjustment, etc., are linearly compensated to reduce the positioning error.

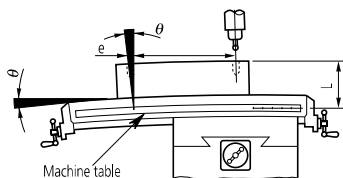

1234 Smoothing function

Turning on smoothing slows display updating to enable the display to be read more easily when a measurement value is rapidly oscillating due to machine vibration. Measurement speed remains unaffected.

A CLR Parameter all clear

Clears the setup parameter data and resets to the default data.

Expansion/contraction coefficient setting

This function multiplies the actual counter measurements by a constant factor. This is useful in, for example, mold manufacture by allowing the mold to be machined to the actual molded component dimensions directly, without having to increase the machining dimensions manually to allow for material shrinkage after molding. Tedious work can thus be reduced and the risk of mistakes in calculation eliminated.

Pitch error correction (KA-200 Counter & AT100 series)

This function allows correction of machine errors, thus improving positioning accuracy.

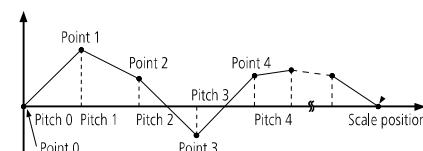

0076 Display value backup

The displayed value at power-off is preserved in memory and restored at the next power-on. When an AT715 scale is connected to the counter, the stored display value is corrected appropriately if the detector head is moved during power off so that the display always shows the correct displacement from the origin.

Function lock (KA-200 Counter)

This function prevents any risk of the operational settings being accidentally changed.

MILLING MACHINE FUNCTIONS



Zero approach machining [INC mode]

Zero approach machining can be repeated at preset intervals. Since the counter keeps the total displacement in absolute coordinates, a positioning error made by the operator at one tooling position has no effect on the remaining positions.

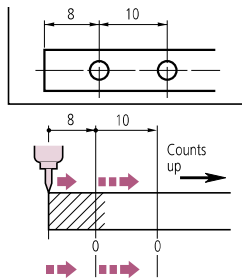

Pitch machining

Bores holes between two arbitrary points on the X-Y plane at equal spaces. By inputting the number of holes and positions of the start and end points, holes can be bored easily at equal spacing. Errors due to table positioning by the machine are automatically corrected to the next target value.

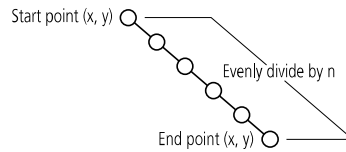

Scale reference point setting

The linear scale has scale reference points at 50mm intervals. When one of the points is detected, the linear scale issues a signal to hold/restart counting. If the distance from a scale reference point to the machine origin is registered as the offset value, it will be retained even when the power is off (hold function). When the power is turned on, the machine origin or machining datum can be easily recalled (set function).

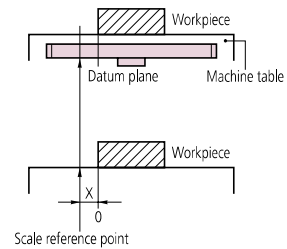

Bolt-hole circle machining

In milling, the drilling positions along the circumference of the base circle in the absolute zero approach mode can be easily displayed by entering the center coordinates, diameter, and number of divisions of the base circle.

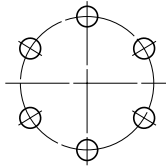

LATHE FUNCTIONS

DIA

Diameter display

The doubled scale displacement can be displayed. This convenient function can be used to display the diameter of a workpiece during a turning operation.

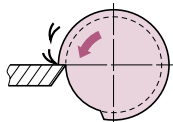

Z1+Z2

Addition of 2-scale data

The sum of the displayed values of two axes can be displayed. If a machine has two feed components, fine feed and coarse feed, each with its own scale, this function can be used to sum the two feed values.

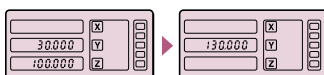

TOOL

Memorization of machining reference point for each cutting tool (for KA-200 Counter)

Absolute coordinate and incremental coordinate can be switched by every one of four cutting tools. The counter can memorize the center of a machining workpiece as a reference point and it can display the diameter of the machine workpiece by using absolute coordinate. The counter can zeroreset/preset at the arbitrary position by using incremental coordinate.

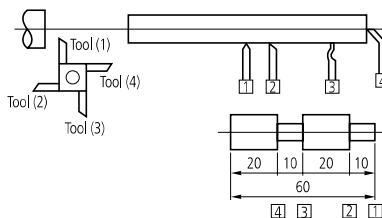

SPECIAL FUNCTIONS

Connection with line driver output scale/linear gage

The KA-200 Counter can also connect with a line-driver output type scale and a linear gage. To connect these sensors use optional LINE conversion adapters. For detailed information, refer to page 30.

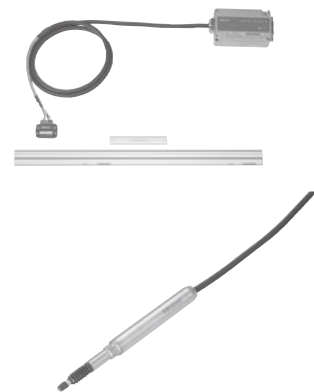

Milling Packages

Electro-Magnetic ABSOLUTE DRO Packages for Milling Machines

Using KA-200 Counter and AT715 Linear Scales

2 Axis, KA-200 Counter Milling System

Package Includes:

- KA-200 Counter
- AT715 Electro-Magnetic Absolute Linear Scales
- Brackets for Linear Scales
- Display Arm Kit

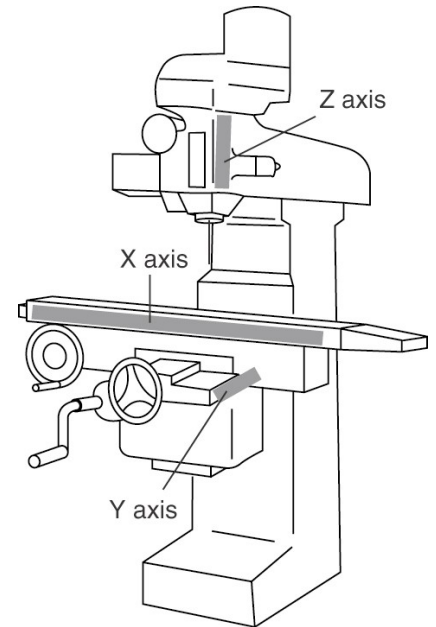

2 Axis Milling Machine System Packages

| X Axis Travel (AT715 Slim Electromagnetic) | Y Axis Travel (AT715 Slim Electromagnetic) | | | |
|--|--|------------------|------------------|------------------|
| | 12" (539-805) | 14" (539-806) | 16" (539-806) | 18" (539-808) |
| 24" (539-811) | 64PKA170 | 64PKA172 | | |
| 30" (539-814) | 64PKA058A | 64PKA060A | 64PKA175 | - |
| 32" (539-815) | | 64PKA169 | 64PKA176 | |
| 36" (539-816) | 64PKA059A | 64PKA168 | 64PKA062A | 64PKA178 |
| 40" (539-817) | 64PKA171 | 64PKA061A | 64PKA063A | 64PKA064A |
| 44" (42") (539-815) | 64PKA173 | | 64PKA177 | |

Milling Packages

Electro-Magnetic ABSOLUTE DRO Packages for Milling Machines

3 Axis (Quill) - AT715 Slim Electromagnetic for all axes

| Order No. | Description |
|-----------|--|
| 64PKA065A | MILL pkg, 3-axis, ABS Scales, 12" x 30" x 6" w/3 axis KA-200 Counter (174-185A) |
| 64PKA066A | MILL pkg, 3-axis, ABS Scales, 12" x 36" x 6", w/3 axis KA-200 Counter (174-185A) |
| 64PKA067A | MILL pkg, 3-axis, ABS Scales, 16" x 36" x 6" w/3 axis KA-200 Counter (174-185A) |
| 64PKA179 | MILL PKG,3-AXIS, ABS SCALES 32" X 14" X 4" w/3 axis KA-200 Counter (174-185A) |
| 64PKA180 | MILL PKG,3-AXIS, ABS SCALES 36" X 14" X 4" w/3 axis KA-200 Counter (174-185A) |
| 64PKA181 | MILL PKG,3-AXIS, ABS SCALES 36" X 16" X 4" w/3 axis KA-200 Counter (174-185A) |
| 64PKA182 | MILL PKG,3-AXIS, ABS SCALES 30" X 14" X 6" w/3 axis KA-200 Counter (174-185A) |
| 64PKA183 | MILL PKG,3-AXIS, ABS SCALES 32" X 14" X 6" w/3 axis KA-200 Counter (174-185A) |
| 64PKA184 | MILL PKG,3-AXIS, ABS SCALES 36" X 14" X 6" w/3 axis KA-200 Counter (174-185A) |
| 64PKA185 | MILL PKG,3-AXIS, ABS SCALES 32" X 16" X 6" w/3 axis KA-200 Counter (174-185A) |
| 64PKA186 | MILL PKG,3-AXIS, ABS SCALES 40" X 18" X 6" w/3 axis KA-200 Counter (174-185A) |
| 64PKA213 | MILL PKG,3-AXIS, ABS SCALES 40" X 16" X 5" w/3 axis KA-200 Counter (174-185A) |
| 64PKA216 | MILL PKG,3-AXIS, ABS SCALES 40" X 12" X 5" w/3 axis KA-200 Counter (174-185A) |
| 64PKA217 | MILL PKG,3-AXIS, ABS SCALES 48" X 18" X 18" w/3 axis KA-200 Counter (174-185A) |
| 64PKA218 | MILL PKG,3-AXIS, ABS SCALES 60" X 24" X 28" w/3 axis KA-200 Counter (174-185A) |
| 64PKA219 | MILL PKG,3-AXIS, ABS SCALES 80" X 32" X 28" w/3 axis KA-200 Counter (174-185A) |
| 64PKA225 | MILL PKG,3-AXIS, ABS SCALES 48" X 18" X 22" w/3 axis KA-200 Counter (174-185A) |

3 Axis (Knee) - AT715 Slim Electromagnetic for all axes

| Order No. | Description |
|-----------|--|
| 64PKA187 | MILL PKG,3-AXIS, ABS SCALES 32" X 13"/14" X 16" w/3 axis KA-200 Counter (174-185A) |
| 64PKA188 | MILL PKG,3-AXIS, ABS SCALES 36" X 13"/14" X 16" w/3 axis KA-200 Counter (174-185A) |
| 64PKA189 | MILL PKG,3-AXIS, ABS SCALES 30" X 14" X 16" w/3 axis KA-200 Counter (174-185A) |
| 64PKA190 | MILL PKG,3-AXIS, ABS SCALES 36" X 16" X 16" w/3 axis KA-200 Counter (174-185A) |
| 64PKA191 | MILL PKG,3-AXIS, ABS SCALES 36" X 16" X 18" w/3 axis KA-200 Counter (174-185A) |
| 64PKA192 | MILL PKG,3-AXIS, ABS SCALES 40" X 18" X 16" w/3 axis KA-200 Counter (174-185A) |
| 64PKA193 | MILL PKG,3-AXIS, ABS SCALES 40" X 18" X 18" w/3 axis KA-200 Counter (174-185A) |
| 64PKA209 | MILL PKG,3-AXIS, ABS SCALES 32" X 16" X 16" w/3 axis KA-200 Counter (174-185A) |
| 64PKA214 | MILL PKG,3-AXIS, ABS SCALES 30" X 12" X 16" w/3 axis KA-200 Counter (174-185A) |
| 64PKA215 | MILL PKG,3-AXIS, ABS SCALES 40" X 12" X 16" w/3 axis KA-200 Counter (174-185A) |

Brackets for Milling Machines

Mounting and Counter Display Brackets

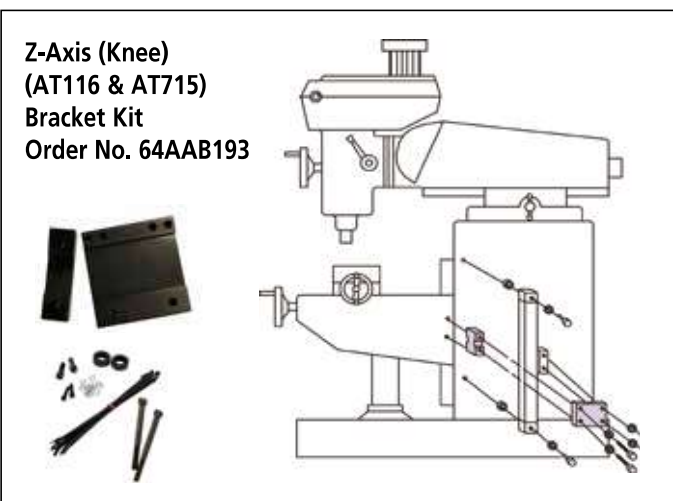
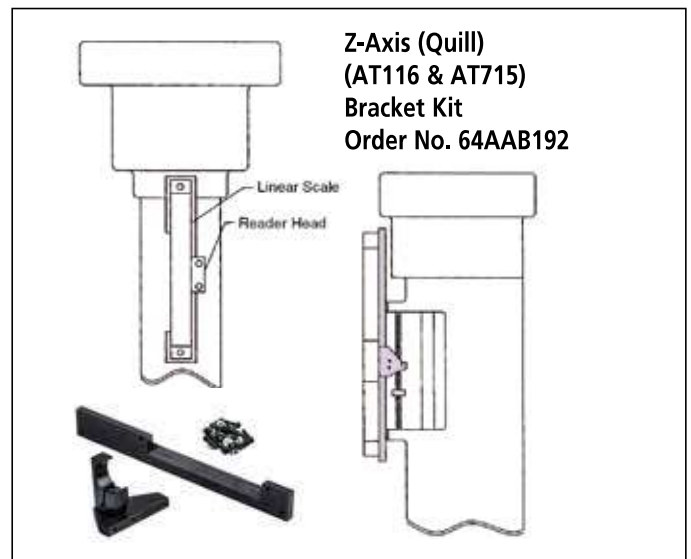
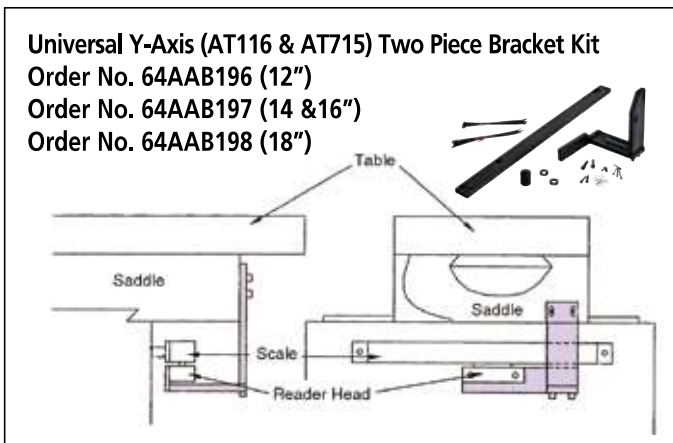
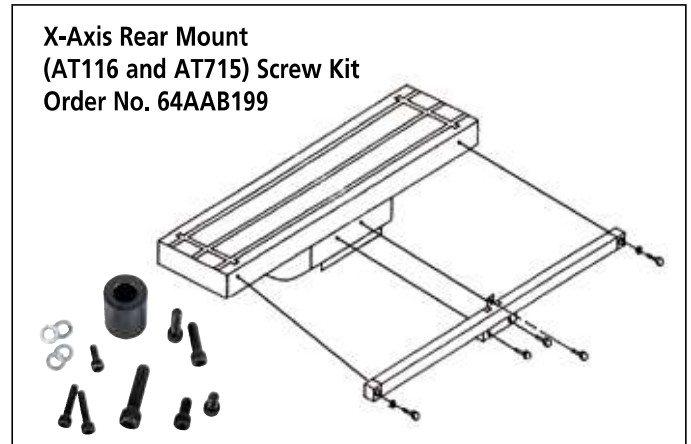
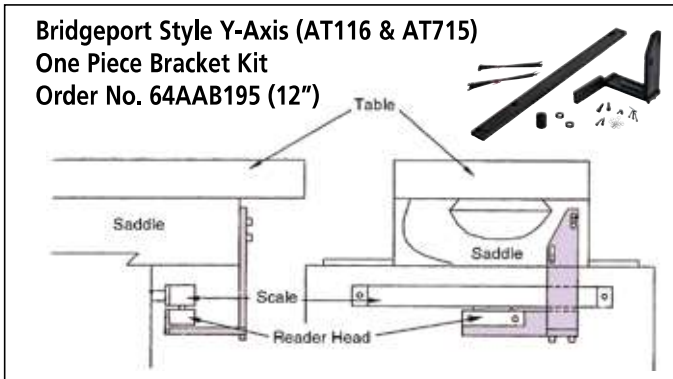

| Order No. | Description | Remark |
|-----------|--|--|
| 64AAB200 | Machine Arm Kit for KA-200 Counter (With Tray) | Current Style |
| 53AAA375 | Tray for KA-200 Counter (Tray Only) | For Kit 64AAB200 and Mini Stand |

Quill Kit for Milling Machines

Quill Kit with Absolute Encoder

Easy Installation Fits Most Vertical Knee Mills

- Easy to read LCD with resolution of .0005"/0.01mm, 0 -6" Travel inch/mm
- Push button controls for inch/mm, Zero-Set and On/Off.
- Powered by a single SR-44 Battery which lasts about 1 year with normal use.
- SPC Output for data transmission to data processors or a remote display.

| Order No. | Description |
|-----------|--|
| 053906B | Digimatic Quill Kit complete with brackets & scale for Bridgeport Type machines. |

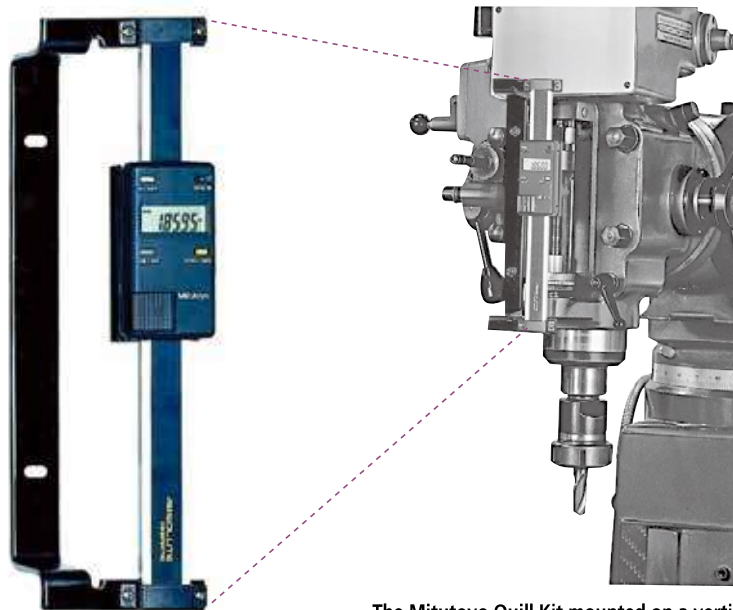

The Mitutoyo Quill Kit mounted on a vertical mill.

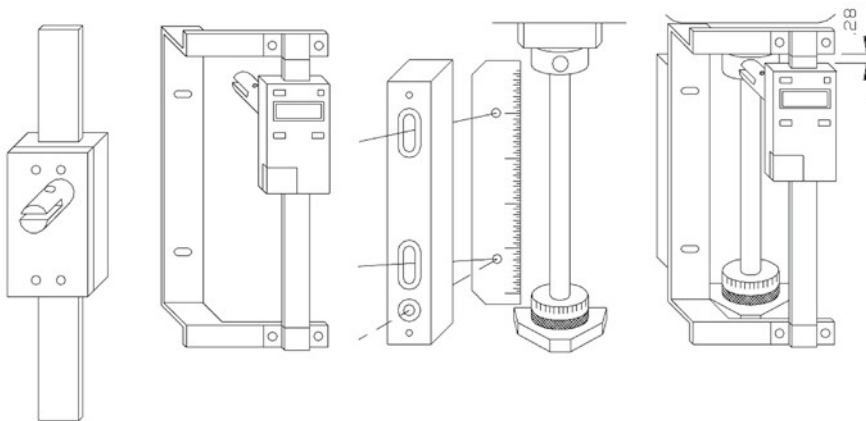

Lathe Packages

Electro-Magnetic ABSOLUTE DRO/Glass Linear Scale Packages for Lathe System



Using KA-200 Counter, AT116 and AT715 Linear Scales

2 Axis, KA-200 Counter Lathe System

Package Includes:

- KA-200 Counter
- AT116 and AT715 Linear Scale combinations
- Bracket Kit (refer to page 15)
- Counter Stand
- Counter Tray

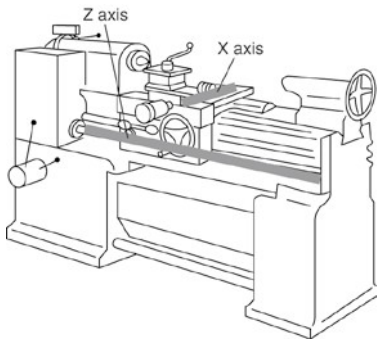

Lathe Machine System Packages

| Z axis travel | X Axis Travel (AT116 Slim Glass Scale) | | | | | |
|---------------|--|------------------|------------------|------------------|---------------------------|------------------|
| | 6"(539-272-30) | 8"(539-273-30) | 10"(539-274-30) | 12"(539-275-30) | 14"(539-276-30) | 16"(539-277-30) |
| 28" (539-813) | 64PKA035A | - | - | - | - | - |
| 30" (539-814) | 64PKA036A | - | - | - | - | - |
| 36" (539-816) | 64PKA037A | 64PKA194 | - | - | - | - |
| 40" (539-817) | 64PKA038A | 64PKA039A | 64PKA042A | 64PKA046A | 64PKA052A | - |
| 44" (539-818) | - | 64PKA040A | 64PKA043A | 64PKA047A | 64PKA053A | - |
| 48" (539-819) | - | 64PKA041A | 64PKA044A | 64PKA048A | 64PKA054A | - |
| 52" (539-820) | - | 64PKA195 | 64PKA198 | 64PKA049A | 64PKA055A | - |
| 60" (539-822) | - | 64PKA196 | 64PKA045A | 64PKA050A | 64PKA056A | 64PKA057A |
| 68" (65") | - | 64PKA220 | - | 64PKA200 | - | - |
| 72" (539-825) | - | - | - | 64PKA051A | - | - |
| 80" | - | 64PKA197 | 64PKA199 | 64PKA210 | 64PKA203 | - |
| 88" (84") | - | - | 64PKA223* | 64PKA201 | - | - |
| 96" (90") | - | - | - | - | 64PKA222 | - |
| 120" | - | - | 64PKA211* | 64PKA202* | 64PKA224/64PKA204* | 64PKA205* |

* indicates Z axis is AT103 series (Glass Linear Scale) instead of AT715. AT103 has a larger cross-section vs AT715.

Brackets for Lathes

Mounting Brackets

Bracket Kit: **64AAB191** Lathe Machine Bracket Kit
53AAA375 Counter tray (for KA-200 Counter)

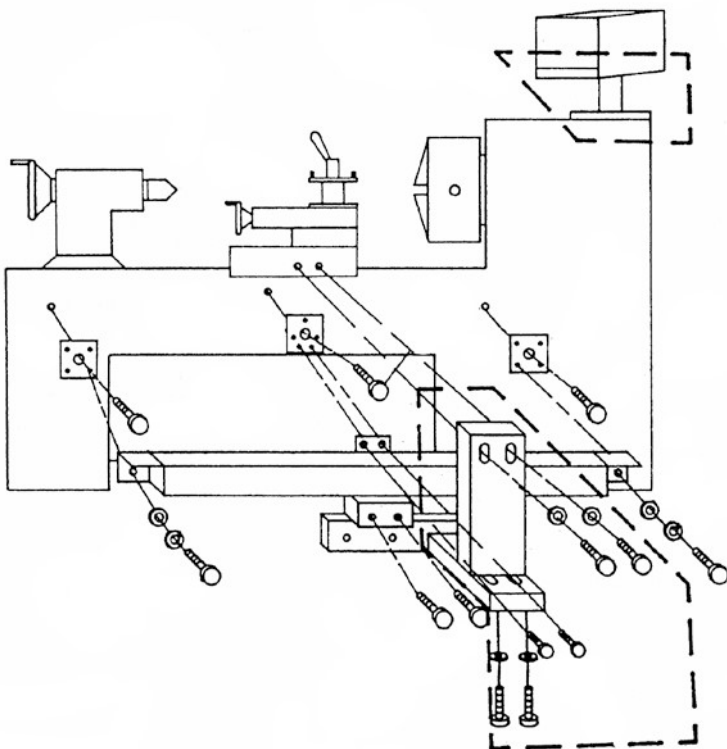
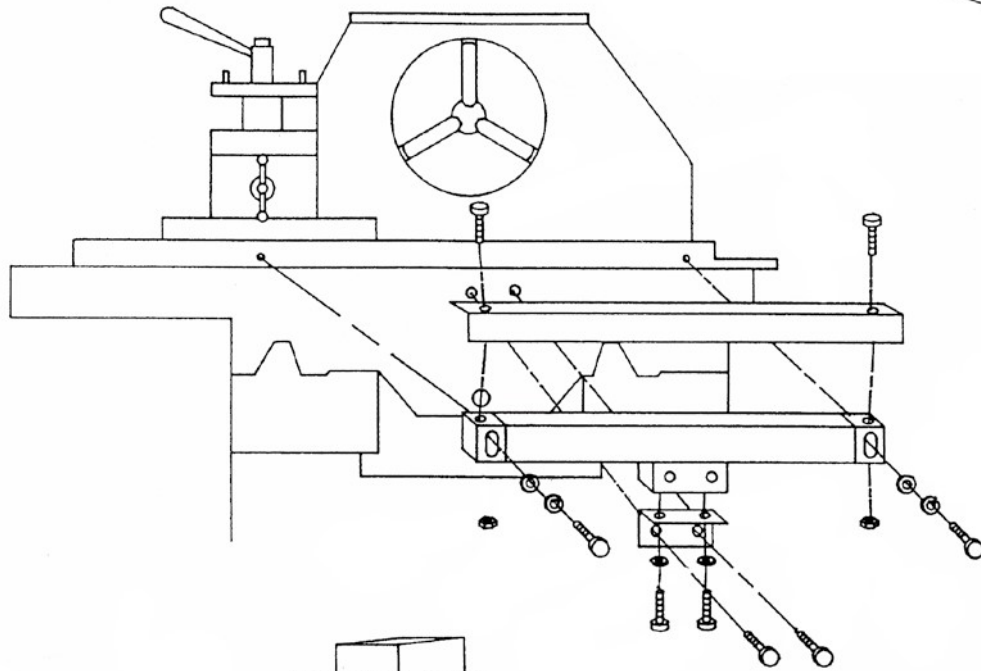
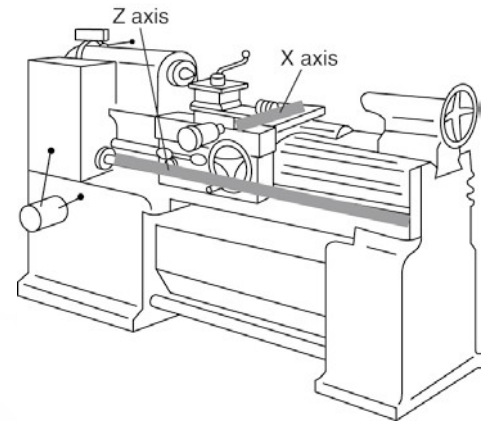

Grinding Packages

High-accuracy Glass Linear Scale Packages for Grinding Machines

Using KA-200 Counter and AT116 Linear Scales



2-axis, KA-200 Counter Grinding System

Package Includes:

- KA-200 Counter
- AT116 Glass Linear Scales
- Bracket Kit (refer to page 19)
- Display Arm Kit



Grinding Machine System Packages

| Vertical | Cross Side (AT116 Slim Glass Scale) | | | | |
|------------------|-------------------------------------|------------------|------------------|------------------|------------------|
| | 6" (539-272-30) | 8" (539-273-30) | 10" (539-274-30) | 12" (539-275-30) | 14" (539-276-30) |
| 12" (539-275-30) | 64PKA026A | 64PKA028A | – | – | |
| 14" (539-276-30) | 64PKA027A | 64PKA029A | – | – | |
| 16" (539-277-30) | – | 64PKA030A | – | – | |
| 18" (539-278-30) | 64PKA206 | 64PKA212 | 64PKA031A | 64PKA033A | |
| 20" (539-279-30) | – | – | – | 64PKA034A | |
| 24" (539-281-30) | – | – | 64PKA032A | 64PKA207 | 64PKA208 |

Also available with AT715 Electromagnetic Linear Scales with IP-67 rating (highest contamination resistance).

Contact your Mitutoyo representative for ordering information.

Brackets for Grinding Machines

Mounting Brackets

Bracket Kit: **64AAB194**, Grinding Linear Scales

Mounting Arm Kit for Counter: **64AAB200**

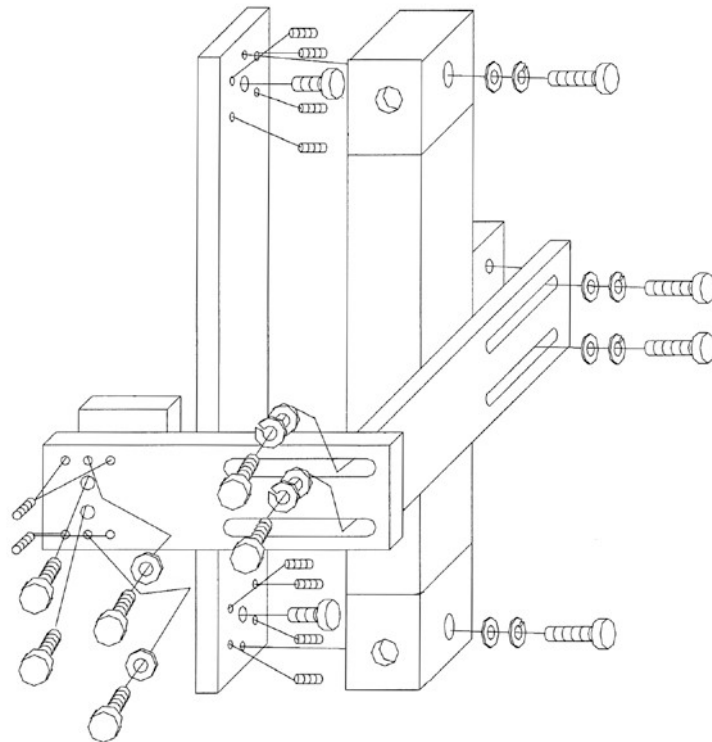
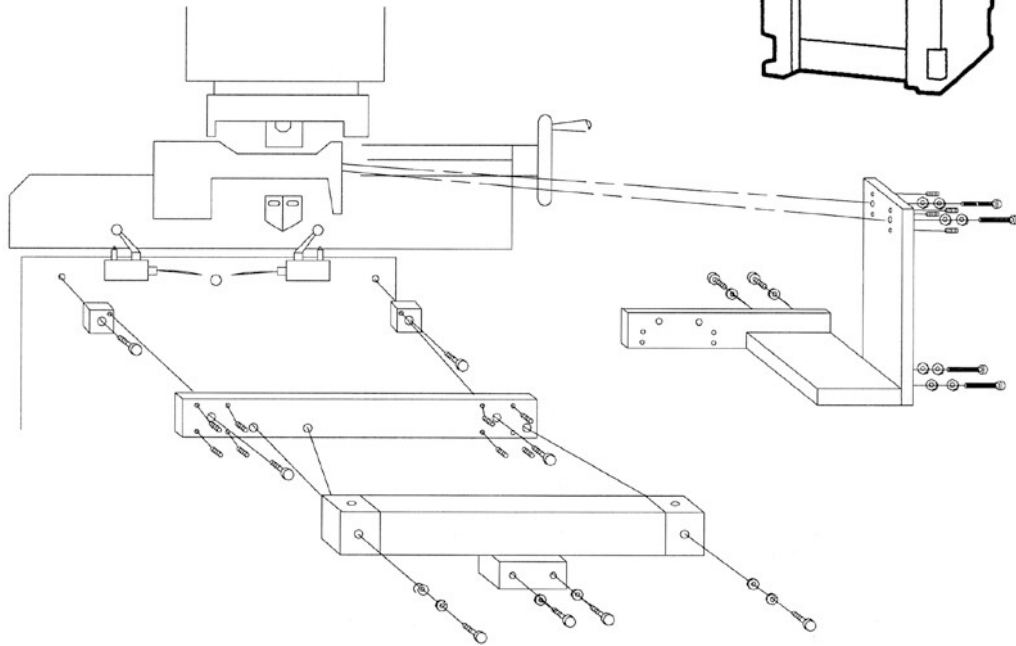
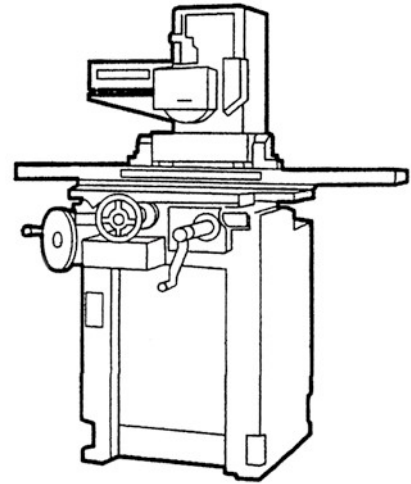

Connecting to External Devices

Mitutoyo's DRO system accurately detects and displays the displacement of machine tool or measuring equipment slideways, and outputs the measurement data and limit signal to a peripheral device such as a PC or PLC through a built-in or optional interface.



RS-232C Interface

- The RS-232C interface unit enables measurement data output, as well as zero-setting, by commands from the computer.

DATA OUTPUT MODE

Interval Mode (KA-200 Counter):
Measurement data can be output at specific intervals.

SPECIFICATIONS

- Communication specifications

| | |
|---------------------------------|---|
| Home position | DCE |
| Communication method | Half-duplex, nonprocedural |
| Data transfer speed (Baud rate) | 300, 600, 1200, 2400, 4800, 9600, 19200, 38400bps |
| Bit configuration | Start bit: 1 Data bit*: 7 or 8 Parity bit: 1 (even, odd), 0 (none) Stop bit: 1 |
| Condition setting | By parameter switching |

- Operation for data output
Counter display values can be output in the following ways. Only one signal type can be used for input at any one time.

| Method | Counter mode | Output axis | Applicable counters |
|--|--------------|---|---------------------|
| Data request command X CR LF Y CR LF Z CR LF A CR LF | Normal mode | X-axis Y-axis Z-axis All axes | KA-200 Counter |
| External extension cable and external load box | Normal mode | Axes that are selected by the external load box | KA |
| External extension cable and foot switch | Normal mode | All axes | KA |

The KA-200 Counter can be controlled externally by executing the following commands through a computer, etc. Command codes must be entered in upper-case characters.

| Function | Command code from PC |
|---|--|
| Zero-setting Sets the counter display values to zero. | RX CR LF: for X-axis RY CR LF*: for Y-axis RZ CR LF*: for Z-axis |
| Error cancellation Has the same effect as the CANCEL key on the counter. | CO CR LF |

- Error code output
If a data output command is issued when the counter is in an error status, or when an incorrect command is issued, the counter outputs a corresponding error code signal.

| Counter display | Code out output |
|--|----------------------------|
| Count overspeed (Error20) | E20 |
| Display overflow (Error30) | E30 |
| Signal error (Error40) | E40 |
| Digital switch setting error (Error50) | E50 (Only for KLD counter) |
| Internal error (Error60) | No response |
| Startup display (-----) | E00 |

Notes

- The output data format is fixed to either 7 or 8 digits, without zero-suppression.
- If data is output from multiple axes, a comma "," is used as a delimiter. e.g. X +12345.678, Y +90123.456 CR LF
- Data is output in the same unit that is used on the counter (mm or inch). However, the unit identifier itself will not be output.

• RS-232C connector

Connector used: 25-pin (KA-200 Counter)

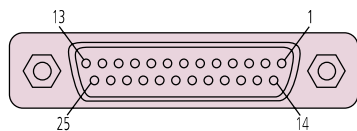

Applicable plug (female)
 • HDBB-25P (plug / HIROSE)
 • HDB-CHT (case / HIROSE)

| No. of pin | Signal | I/O | Remarks |
|------------|--------|--------|---------------------|
| 1 | FG | — | Frame grounding |
| 2 | SD | Input | Command |
| 3 | RD | Output | Data |
| 4 | — | — | Not used |
| 5 | CS | Output | "H" fixed |
| 6 | DR | Output | "H" fixed |
| 7 | SG | — | Signal grounding |
| 8 to 12 | — | — | Not used |
| 13 | — | Input | X-axis load |
| 14 | — | Input | Y-axis load |
| 15 | — | — | Not used |
| 16 | — | Input | Z-axis load |
| 17 to 22 | — | — | Not used |
| 23 | — | Input | X-axis zero-setting |
| 24 | — | Input | Y-axis zero-setting |
| 25 | — | Input | Z-axis zero-setting |

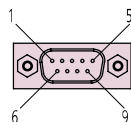

Applicable plug (female)
 • HDEB-9S (plug / HIROSE)
 • HDE-CHT (case / HIROSE)

| No. of pin | Signal | I/O | Remarks |
|------------|--------|--------|------------------|
| 1 | — | — | Not used |
| 2 | RD | Output | Data |
| 3 | SD | Input | Command |
| 4 | — | — | Not used |
| 5 | SG | — | Signal grounding |
| 6 | DR | Output | "H" fixed |
| 7 | — | — | Not used |
| 8 | CS | Output | "H" fixed |
| 9 | — | — | Not used |

• Optional RS-232C code out unit for KA-200 Counter: **06AET993**

The optional code out unit enables measurement data output to a peripheral device such as a PC or DP-1VA, as well as zero-setting by commands from PC or the external zero-set box.

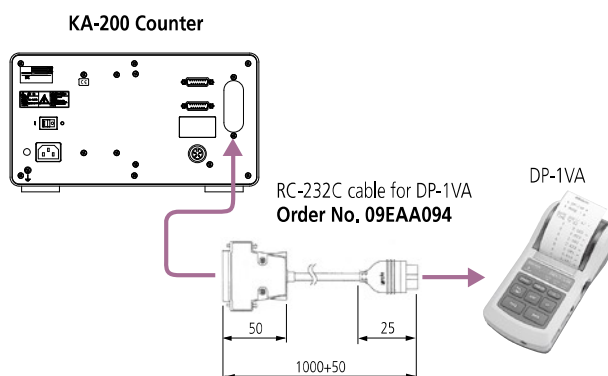

- External extension cable (KA-200 Counter only). By attaching an external extension cable to a KA-200 Counter + RS-232C code out unit, the optional external load box, foot switch and external zero set box can be connected. RS-232C outputs can be used together.

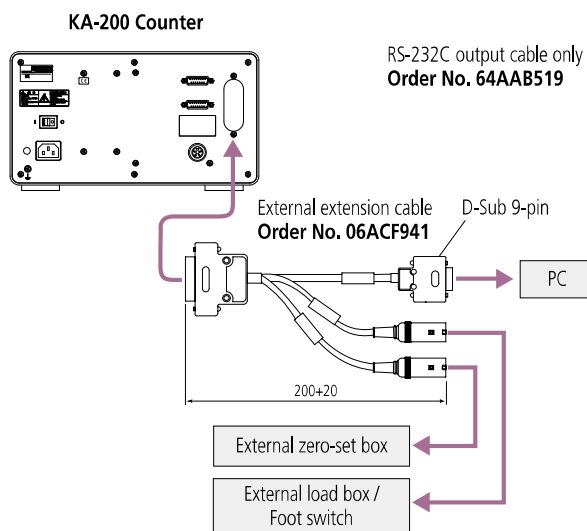

Optional Accessories

External Load Box

Outputs counter value just by pressing the button when using the counter's data output function.

For KA-200 Counter (equipped with RS-232C output).

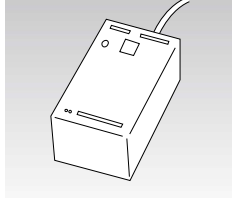

| Part No. | Number of axis |
|----------|----------------|
| 937328 | 3-axis |

Note 1: Both of the counter and the external zero-set box have to have the same number of axis.
 Note 2: When using for KA-200 Counter, a cable for external connection is also required.

Counter Support

Holds KA series counters.



| | |
|----------|----------|
| Part No. | 64AAB200 |
|----------|----------|

Digimatic Mini-Processor DP-1VA

Prints out the displayed data when connected with RS-232C output of KA-200 Counter. For connection, use RS-232 Counter cable (1m).
 (For KA-200 (RS-232C output) Counter.)



| Order No. | Product Name |
|------------|-----------------------|
| 264-504-5A | DP-1VA |
| Part No. | Product Name |
| 09EAA094 | RS-232C counter cable |

External Zero Box

Zeroes the counter just by pressing the button when using the counter's data output function.

(For KA-200 (equipped with RS-232C output) Counter.)

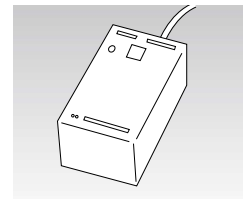

| Part No. | Number of axis |
|----------|----------------|
| 936553 | 3-axis |

Note 1: Both of the counter and the external zero-set box have to have the same number of axis.
 Note 2: When using for KA-200 Counter, a cable for external connection is also required.

Code Out Unit

RS-232C/USB unit to be mounted on the counter.
 (For KA-200 Counter)

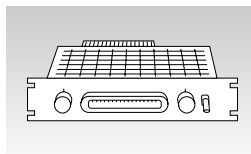

| Part No. | Product name |
|----------|---------------|
| 06AET993 | Code Out Unit |
| 937179T | Foot switch |

Cable for External Connection

External zero-set box, external load box and external load foot switch can be used when connected with RS-232C output of KA-200 Counter. Combination use with RS-232C output is available.

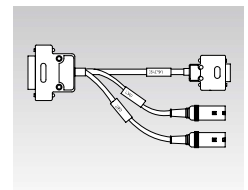

| | |
|----------|----------|
| Part No. | 06ACF941 |
|----------|----------|

External Load Foot Switch

Connects to the external load/zero cable (06ACF941) when also using the optional RS-232C card of KA, KS and KC counters. The foot switch can be used to output the displayed data.

| | |
|----------|--------|
| Part No. | 965004 |
|----------|--------|



Connects to the output trigger port on the back of the KA-200 Counter and triggers RS-232C output when using the optional RS-232C card. (09CAB217 for KA, or RS-232C output from 06AET993 for KA-200)

| | |
|----------|----------|
| Part No. | 64AAB336 |
|----------|----------|



Extension Cable

Use the extension cable to extend the cable attached to the linear scale when the linear scale and the counter are placed far apart. The Type A extension cable is provided with a water-proof connector. (The Type A is not compatible with the AT115, AT116 and AT715 Linear Scale units.)

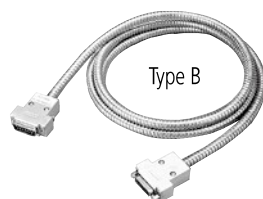
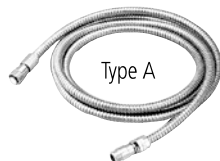

Cable Type A for AT102/103/111/112/113/181 (Only)

| Cable Length | Order No. | Mass |
|--------------|-----------|--------|
| 6.5 ft (2m) | 09AAA033A | 0.35kg |
| 16.4 ft (5m) | 09AAA033B | 0.75kg |
| 22.9 ft (7m) | 09AAA033C | 1.01kg |

Note: Do not allow the entire length of the cables to exceed 20m.

Cable Type B for AT715/AT115/AT116 and AT102/103/111/112/113/181 (db 15 connectors)

| Cable Length | Order No. | Mass |
|--------------|-----------|--------|
| 6.5 ft (2m) | 09AAB674A | 0.35kg |
| 16.4 ft (5m) | 09AAB674B | 0.75kg |
| 22.9 ft (7m) | 09AAB674C | 1.01kg |

Note: Do not allow the entire length of the cables to exceed 20m.

Adapter Cross Reference

(for adapting old linear scales to new counters, or new linear scales to old counters)



09AAA207



09AAA198

| | Linear Scale Series No. | Adapter No. | Counters |
|--|--|-------------|---|
| Old Linear Scales with 6 pin round connectors | FOR AT2-N, AT2, AT-11N, AT11, AT12N (529 Series) | 09AAA207 | All KA, KS, KC, UDR Series Counters with 15 pin connectors. (All 174 Series) |
| Current/new Linear Scales with 15 pin D-Sub connectors | FOR AT102, AT103, AT111, AT112, AT113, AT115, AT116, AT181 | 09AAA181 | For all .0001" resolution counters with seven pin round connectors |
| | | 09AAA181V* | APL Counter 164-660*, 164-661*, 164-662* MPK-2L 983-352 |
| | | 09AAA198 | For all .0005" resolution counters with six pin round connectors |
| | | 09AAA198V* | APL Counter 164-660*, 164-661*, 164-662*, 164-563*, 164-664*, 164-665* PL and PL Zero Output Counter 164-252A, 164-254A, 164-295A |

* V = Vertical type

When only replacing one linear scale, you can use either horizontal or vertical type adapter.

PSU-200

Pulse Signal Conversion Interface

FEATURES

- +5VDC external power supply.
- Applicable with linear scales with the sinusoidal signal output.
- Quadrature signal output (conforming to EIA standard RS422-A).
- Alarm function for detecting broken wires or short circuits in the detector, over-speed and fluctuation errors in the input signal from the detector.
- LED indications. Origin signal input alarm for power supply (voltage drop and noise).
- DIP switch functions. Direction switching. Mode switching (high impedance/alarm signal output). Division selection (4/8/10/20/40/80/100/200) Min. edge interval selection (1000/500/250/125/62.5ns)



| Order No. | Model Name |
|-----------|------------|
| 539-005 | PSU-200 |

SPECIFICATIONS

| | |
|-----------------------|--|
| Number of axes | 1 axis |
| Number of deviation | 4, 8, 10, 20, 40, 80, 100 or 200 (switchable) |
| Functions | Division setting: 4/8/10/20/40/80/100/200 Min. edge interval setting: 1000/500/250/125/62.5ns Direction switching LED for alarm indication: Broken wires and short circuits in the linear scale, abnormal signal, over speed Alarm output mode switching: High impedance output/alarm signal output external alarm reset (photo-coupler input) LED for origin detection LED for low-level power supply voltage warning |
| Power supply | 5VDC±5% on the power terminal |
| Consumption | 200mA (except the scale) |
| Operating temperature | 0°C to 40°C |
| Mass | Approx. 620g (1.4 lbs) |

Applicable Linear Scale*

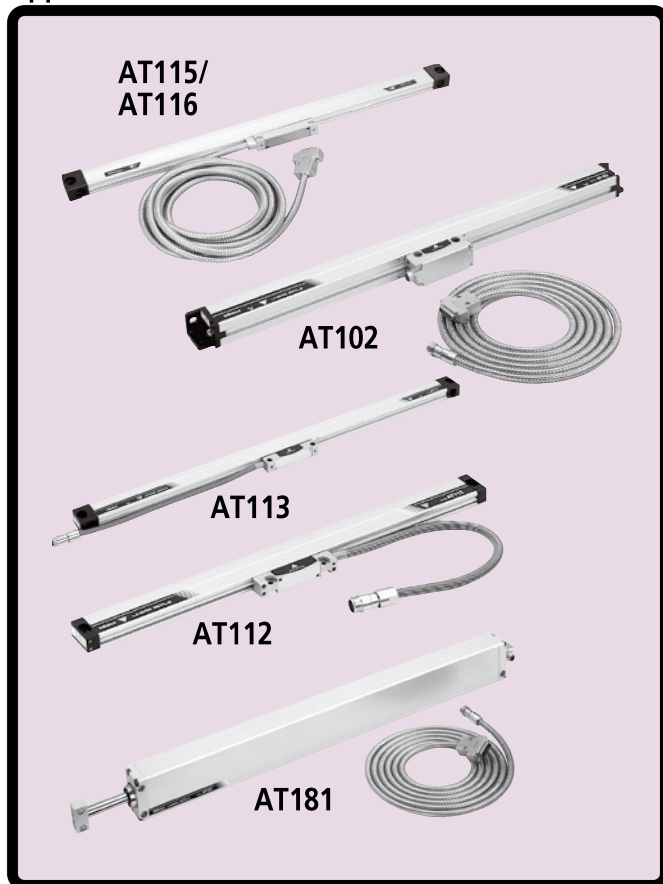

*Does not work with AT715 electromagnetic scales



Input Connector

■ Connector:
D-Sub 15S

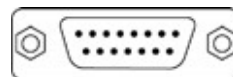

| Pin No. | Signal name |
|---------|-------------|
| 1, 2 | 0V |
| 3, 4 | +5V |
| 5 | ØA |
| 6 | ØB |
| 7 | Vref |
| 8 | ØZ |
| 9 | AL |
| 10 - 14 | NC |
| 15 | F.GND |

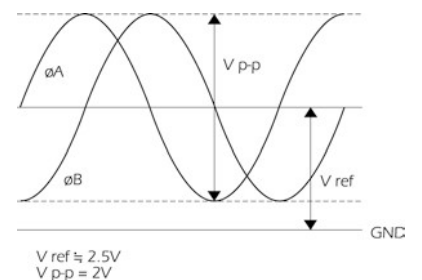

Arrangement of cable connection

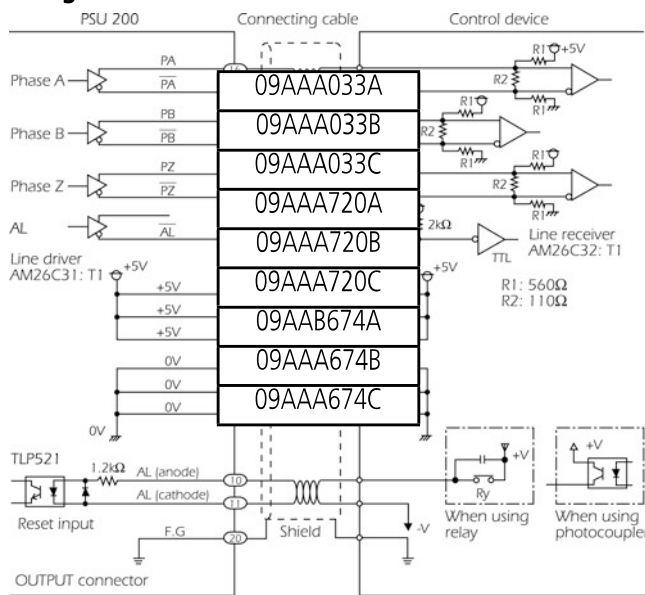

Reset input: Design the connection so that the current of the alarm reset input is between 3mA and 10mA. An alarm can be reset by supplying a voltage of 5V to 12V between the anode and cathode terminals because a resistor (1.2kW) is provided inside the PSU200. If the voltage is greater than 12V, add an appropriate external resistor.

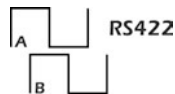

Output Connector

- Connector: MR20RM [Manufacturer: Honda Tsushin]
- Applicable plug (standard accessory): MR20LF [Manufacturer: Honda Tsushin]

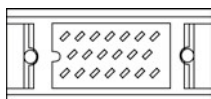

| Pin No. | Signal name |
|---------|-------------|
| 1, 2 | 0V |
| 3, 4 | +5V |
| 5 | ØA |
| 6 | ØB |
| 7 | Vref |
| 8 | ØZ |
| 9 | AL |
| 10 - 14 | NC |
| 15 | F.GND |

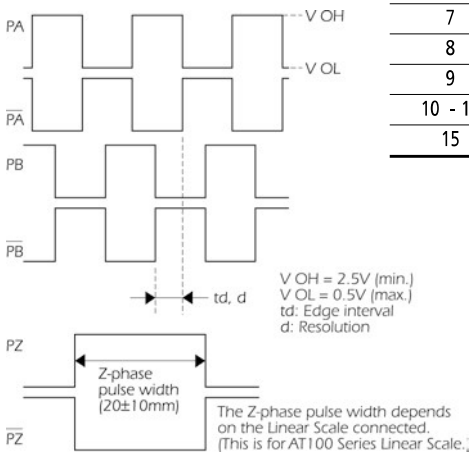

Dimensions

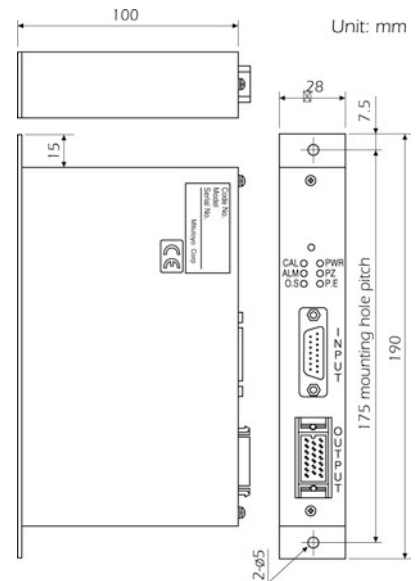

Maximum response speed

| Deviation | Min. edge interval ³ | Input signal pitch ² | | |
|-----------|---------------------------------|---------------------------------|-----------|----------|
| | | 4µm | 8µm | 20µm |
| 4 | 62.5ns | 120m/min | 240m/min | 600m/min |
| | 125ns | 120m/min | 240m/min | 600m/min |
| | 250ns | 120m/min | 240m/min | 600m/min |
| | 500ns | 120m/min | 240m/min | 600m/min |
| | 1ms | 60m/min | 120m/min | 300m/min |
| 8 | 62.5ns | 120m/min | 240m/min | 600m/min |
| | 125ns | 120m/min | 240m/min | 600m/min |
| | 250ns | 120m/min | 240m/min | 600m/min |
| | 500ns | 60m/min | 120m/min | 300m/min |
| | 1ms | 30m/min | 60m/min | 150m/min |
| 10 | 62.5ns | 120m/min | 240m/min | 600m/min |
| | 125ns | 120m/min | 240m/min | 600m/min |
| | 250ns | 96m/min | 192m/min | 480m/min |
| | 500ns | 48m/min | 96m/min | 240m/min |
| | 1ms | 24m/min | 48m/min | 120m/min |
| 20 | 62.5ns | 120m/min | 240m/min | 600m/min |
| | 125ns | 96m/min | 192m/min | 480m/min |
| | 250ns | 48m/min | 96m/min | 240m/min |
| | 500ns | 24m/min | 48m/min | 120m/min |
| | 1ms | 12m/min | 24m/min | 60m/min |
| 40 | 62.5ns | 96m/min | 192m/min | 480m/min |
| | 125ns | 48m/min | 96m/min | 240m/min |
| | 250ns | 24m/min | 48m/min | 120m/min |
| | 500ns | 12m/min | 24m/min | 60m/min |
| | 1ms | 6m/min | 12m/min | 30m/min |
| 80 | 62.5ns | 48m/min | 96m/min | 240m/min |
| | 125ns | 24m/min | 48m/min | 120m/min |
| | 250ns | 12m/min | 24m/min | 60m/min |
| | 500ns | 6m/min | 12m/min | 30m/min |
| | 1ms | 3m/min | 6m/min | 15m/min |
| 100 | 62.5ns | 38.4m/min | 76.8m/min | 192m/min |
| | 125ns | 19.2m/min | 38.4m/min | 96m/min |
| | 250ns | 9.6m/min | 19.2m/min | 48m/min |
| | 500ns | 4.8m/min | 9.6m/min | 24m/min |
| | 1ms | 2.4m/min | 4.8m/min | 12m/min |
| 200 | 62.5ns | 19.2m/min | 38.4m/min | 96m/min |
| | 125ns | 9.6m/min | 19.2m/min | 48m/min |
| | 250ns | 4.8m/min | 9.6m/min | 24m/min |
| | 500ns | 2.4m/min | 4.8m/min | 12m/min |
| | 1ms | 1.2m/min | 2.4m/min | 6m/min |

* The maximum response speed may be limited depending on the response speed of the linear scale itself.

Optional Adapters

When using an optional extension cable

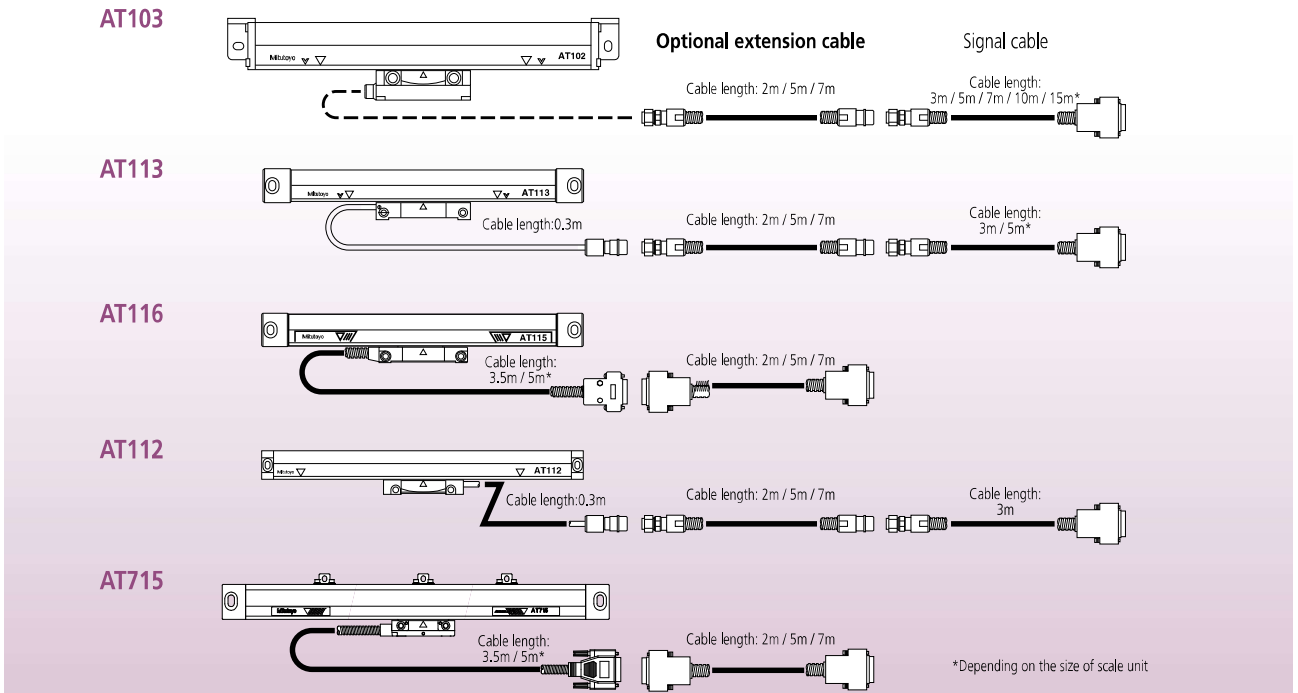

Line Conversion Adapter

Connects a line-driver-output linear scale, a linear gage and a KA-200 Counter.

Configuration of line-driver output models and connecting adapters for the KA-200 Counter

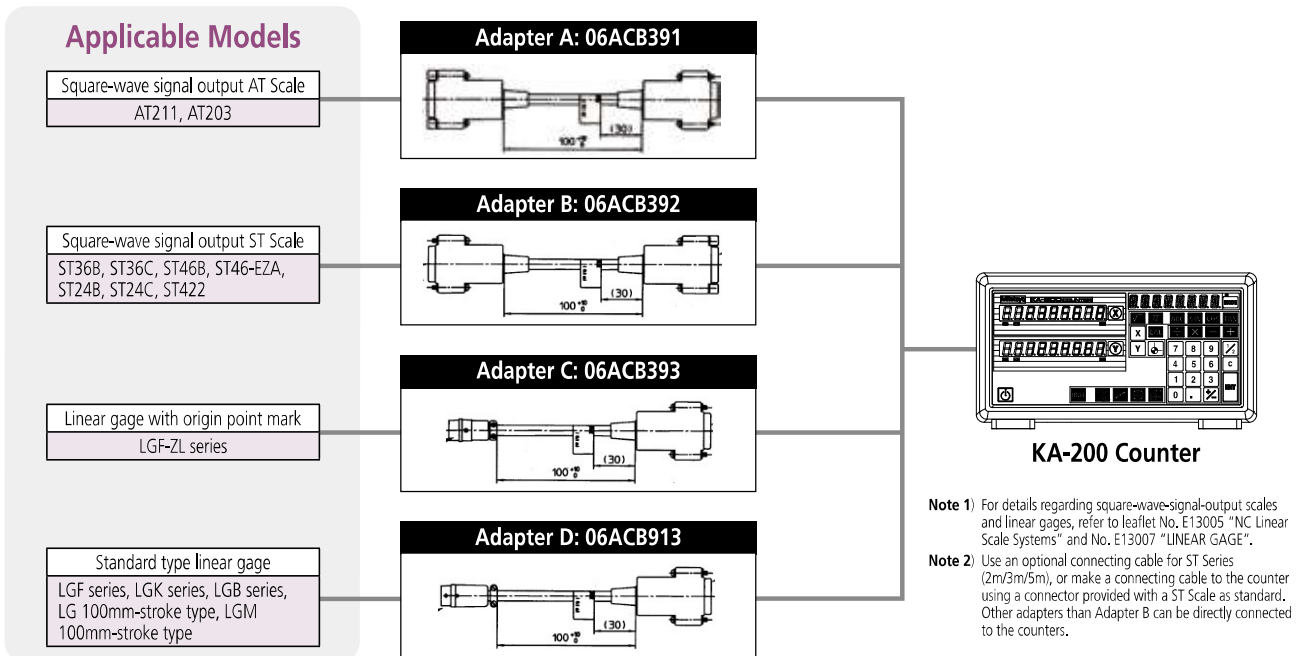

CAUTION



When using adapters A to D, maximum response speed is determined by the resolution of the connected models.

When the parameter 96 of the KA-200 Counter is set to 5 (input frequency: 300kHz)

| Connected model's resolution | Maximum response speed |
|------------------------------|------------------------|
| 1μm | 300mm/s |
| 0.5μm | 150mm/s |
| 0.2μm | 60mm/s |
| 0.1μm | 30mm/s |

Replacement Parts

| Order No. | Description | Remark |
|------------------|--------------------------------------|---|
| – | AT102 Read Head | Contact Mitutoyo |
| 09AAA278 | AT102 Read Head for Extra-Long Scale | 3250mm and Longer |
| 06ADK738 | AT103 Read Head | |
| 09AAA006 | AT112 Read Head | |
| 06ACX822 | AT113 Read Head | |
| – | AT115 Read Head (3m cable) | Contact Mitutoyo |
| – | AT115 Read Head (5m cable) | Contact Mitutoyo |
| – | AT116 Read Head (3.5m cable) | Contact Mitutoyo |
| – | AT116 Read Head (5m cable) | Contact Mitutoyo |
| 09AAB661A | AT715 Read Head (3.5m cable) | Special calibration required. Contact Mitutoyo. |
| 09AAA030A | Signal Cable (9.9'/3m) | For AT102, 103, 111, 112, 113, 181 |
| 09AAA030B | Signal Cable (16.5'/5m) | For AT102, 103, 111, 112, 113, 181 |
| 09AAA030C | Signal Cable (23.1'/7m) | For AT102, 103, 111, 112, 113, 181 |
| 09AAA030D | Signal Cable (10m) | For AT102, 103, 111, 112, 113, 181 |
| 09AAA030E | Signal Cable (15m) | For AT102, 103, 111, 112, 113, 181 |

Extension Cables

| Order No. | Description |
|------------------|---------------------------------------|
| 09AAA033A | 2m-For AT102, 103, 111, 112, 113, 181 |
| 09AAA033B | 5m-For AT102, 103, 111, 112, 113, 181 |
| 09AAA033C | 7m-For AT102, 103, 111, 112, 113, 181 |
| 09AAB674A | 2m-For AT715, AT115, 116 |
| 09AAA674B | 5m-For AT715, AT115, 116 |
| 09AAA674C | 7m-For AT715, AT115, 116 |

Lip Seal Replacements

| Order No. | Description | Length (in) | Cut Length (in) | Applicable Linear Scales |
|-----------------|--------------------------------------|-------------|-----------------|---|
| 64AAB153 | DUST PROOF LIP SEAL, STD TYPE, 20" | 20 | 28 | AT102, AT103, AT300, AT203, AT2, AT21, AT31 |
| 64AAB154 | DUST PROOF LIP SEAL, STD TYPE, 40" | 40 | 48 | |
| 64AAB155 | DUST PROOF LIP SEAL, STD TYPE, 60" | 60 | 68 | |
| 64AAB156 | DUST PROOF LIP SEAL, STD TYPE, 80" | 80 | 88 | |
| 64AAB157 | DUST PROOF LIP SEAL, STD TYPE, 100" | 100 | 108 | |
| 64AAB158 | DUST PROOF LIP SEAL, STD TYPE, 120" | 120 | 128 | |
| 64AAB159 | DUST PROOF LIP SEAL, STD TYPE, 140" | 140 | 148 | |
| 64AAB160 | DUST PROOF LIP SEAL, STD TYPE, 160" | 160 | 168 | |
| 64AAB161 | DUST PROOF LIP SEAL, STD TYPE, 180" | 180 | 188 | |
| 64AAB162 | DUST PROOF LIP SEAL, STD TYPE, 200" | 200 | 208 | |
| 64AAB163 | DUST PROOF LIP SEAL, STD TYPE, 220" | 220 | 228 | |
| 64AAB164 | DUST PROOF LIP SEAL, STD TYPE, 240" | 260 | 268 | |
| 64AAB165 | DUST PROOF LIP SEAL, SLIM TYPE, 20" | 20 | 28 | |
| 64AAB166 | DUST PROOF LIP SEAL, SLIM TYPE, 40" | 40 | 48 | |
| 64AAB167 | DUST PROOF LIP SEAL, SLIM TYPE, 80" | 80 | 88 | |
| 64AAB466 | DUST PROOF LIP SEAL, SLIM TYPE, 140" | 140 | 148 | |

Precautions when mounting and handling linear scales

Selecting the scale unit mounting position and mounting method

It is important to keep in mind the following points when determining the scale unit mounting position and orientation.

Ease of mounting

Mount the scale unit making sure that the unit including the detector head and the cables does not interfere with any part of the machine. To facilitate mounting, mount the scale unit and the brackets on machined surfaces wherever possible.

Protection from machining fluids and swarf (mounting orientation)

The scale unit is constructed in such a way that machining fluids and swarf cannot easily enter into the interior of the unit. However, since the openings are protected from entry of foreign material with rubber seals only, avoid directly exposing the scale unit to machining fluids and swarf. Select the mounting orientation of the scale unit after carefully considering the direction in which machining fluids and swarf are sprayed and scattered.

Accuracy considerations

The total system accuracy of the machine on which the scale unit is mounted is not only determined by the scale unit accuracy but by the machine accuracy as well. Particularly for machines with slide tables, geometrical errors may occur, depending on the straightness of moving parts; thus, the scale unit must be mounted in a way that these errors are minimized. If the slide table moves not linearly but curvilinearly, errors occur in proportion to the distance "L" between the scale unit and the machining point (cutter position). Thus, mount the scale unit in a position that minimizes "L".

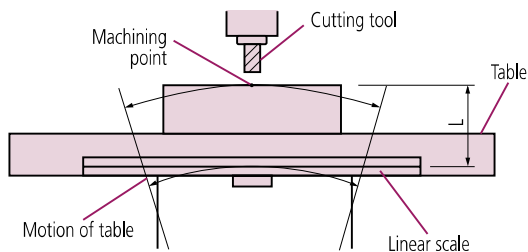

Other considerations

- If the detector head moves, the signal cables also move with the slide table. This should be considered when laying out the signal cables. It is therefore recommended to mount the scale unit on the moving part of the machine.
- Mount the scale unit in place where it is not directly subjected to airflow. When removing swarf using an air gun, be careful of flying swarf.
- The scale unit must be mounted in a place where maintenance can be easily performed in case unit trouble occurs.

Checking parallelism and adjustment of scale unit

In order to attain maximum accuracy, the scale unit must be mounted parallel to the machine guide (machining axis). Incorrect mounting may cause the scale unit to bend or twist.

Checking parallelism

Use a dial indicator as shown in the figure below. To adjust the parallelism between the scale unit and the machine guide, check the parallelism while manually moving the machine's movable part such as the slide table, or measure the parallelism with reference to the guideways of the machine or equivalent reference surface.

- Parallelism tolerance: Refer to each figure on dimensions.
- Checking direction: Back/forward direction on mounting surface and directions along mounting surface (up and down).
- Checking position: Position of scale unit around the mounting blocks.

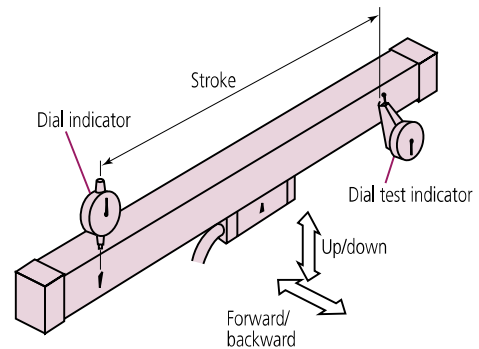

Adjusting parallelism

Adjust the parallelism to within 0,2mm. Spacers used in adjustment are not included in the accessories.

- Adjusting the mounting surface back/forward: Readjust the mounting positions of the brackets or place spacers between the scale unit mounting surface and the mounting blocks.
- Adjusting along (up and down) the mounting surface: Adjust the parallelism by sliding the mounting block on the mounting surface.

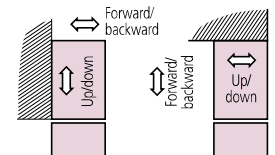

Information about Air Supply (Improvement in Dust and Oil Resistance)

Feeding clean compressed air into the scale unit is provided as a means of improving the environmental resistance (to coolant and dust) of assembly-type linear scales. This is done by piping air to either of two M5 screw holes situated on the sides of the scale unit.

* AT103 is equipped as standard with an air supply fitting.

Caution: This air supply method is suggested as optional protection for the scale. The installation of the air supply piping is important and should be implemented as described in the manual. The air should be filtered and the filter replaced periodically, depending on the cleanliness of the air source. Continued use of a heavily contaminated filter may allow contaminants to pass into the scale unit.

For detailed information, contact Mitutoyo Sales Department.

Signal cable layout

It is important to keep in mind the following points when deciding on the layout scheme for signal cables.

When the cable is fixed

The radius of curvature of the signal cable must be larger than 50mm.

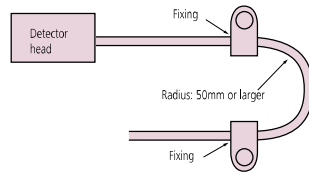

Other considerations

The signal cable is durable enough to withstand repeated bending up to approximately 2 million times (when the bending radius is limited to more than 100mm). When repeated bending exceeding 2 million times is expected, the signal cable should be considered as a consumable part. In such a case, carrying a spare cable will allow immediate replacement when necessary and minimize machine downtime.

When the cable is movable

When the detector head is the moving element, it carries the signal cable with it during operation. Take care, in such a case, that the radius of curvature of the signal cable is not smaller than 100mm and excessive force is not applied to the cable. It is a good idea to protect the cable with a flexible support cover.

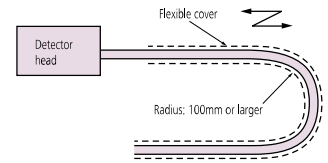

Note) It is important to ensure that the signal cable does not interfere with, and is not chafed by, any part of the machine.

Resonance point of linear scale

Each object has a natural frequency, depending on its shape, length, and the type of material. The linear scale frame is not an exception. It has a natural frequency and thereby resonates at a certain frequency. In general, this will not cause a problem, since a machine tool and the Linear Scale frame have different natural frequencies under normal machining conditions. However, should the natural frequency of the machine tool body and the linear scale coincide, the following counter-measures can be taken:

1. Increase rigidity of the mounting bracket for the scale.
2. Add a mid-support to the middle of the scale to shift its resonance point higher.
3. Mount the linear scale at a place where vibrations from the machine tool cannot be easily transmitted.
4. Limit the machine process conditions to be within a specific range in which the natural frequencies of the machine tool and the scale do not coincide.

Maintenance of dust-proof seals

In order to maintain and extend the life of the dust-proof rubber seals, it is recommended that a small amount of silicon lubricant be applied to the contact area between the rubber and the detector head once a year.

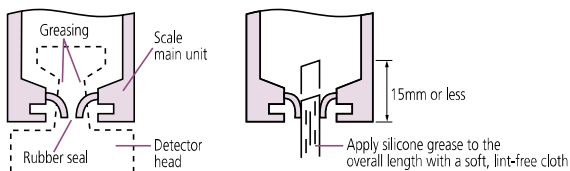

Linear scale evaluation methods

- **Testing within the operating temperature range**
Testing has proven that there is no abnormality of functions and signals when the linear scale is used within the specified operating temperature range.
- **Temperature cycle (dynamic characteristics) test**
Testing has proven that there is no abnormality when the linear scale is used under the condition where the ambient temperature continuously changes within the specified range.
- **Vibration test (Sweep test)**
Testing has proven that the linear scale functions without abnormality when subject to vibration within the frequency range 30Hz to 300Hz at a maximum acceleration of 3g.
- **Noise test**
In accordance with the EMC Directives, EN61326-1+A1:1998
- **Crate drop test**
In accordance with the heavy equipment drop test (JISZ0200) specified in the JIS standard.

Constructional features of the linear scale

Joint structure of detector

A ball joint structure is employed at the contact area between the detector head and the slider (sensor unit) inside the scale. This arrangement prevents the slider movement from deviating from the normal moving directions when the detector head is slightly misaligned transversely, thus providing a normal scale reading and increasing flexibility in the scale installation. In addition, this structure is highly rigid and, therefore, has excellent durability.

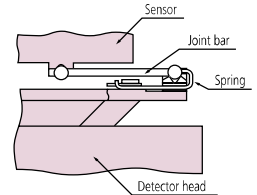

Water-proof connector

A waterproof/splash-proof connector is used to enable separation of the signal cable. Thus, installation and maintenance of the Linear Scale can be easily performed. (The signal cable on the AT115 cannot be separated.)

Conduit-armored type signal cable

The signal cable is protected by the conduit system. Its exterior is made of stainless steel, which is corrosion-resistant and withstands continuous use.

Unique rubber seals

The slider is shaped to glide smoothly through the rubber-seal opening.

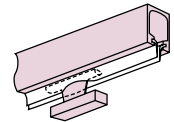

Excellent splash- and dust-proof rubber-seal structure

The rubber seals are made of a strong, special urethane, and wires are inserted in these seals to improve the splash-proofing and dust-proofing of the scale (AT103 only).

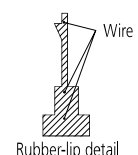
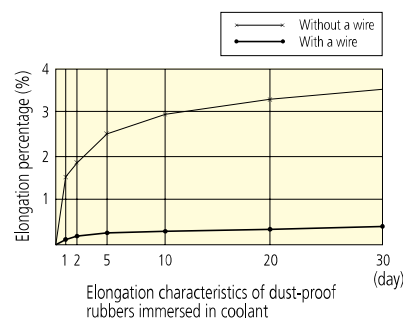

Operating Principles

Operating Principle of AT100 Series

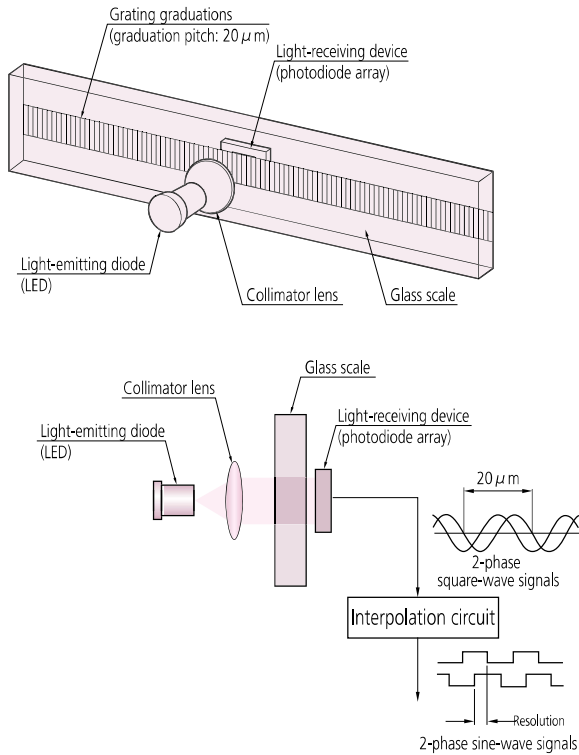

The assembly-type Linear Scale® uses a highly accurate glass scale grating pitch of $20\ \mu\text{m}$ as the basic standard of length. The grating is irradiated with parallel light generated with a Light-Emitting Diode (LED) and collimator lens. The parallel light transmitted through the grating generates an interference pattern with the same pitch as that of a grating on the photodiode array of the light-receiving device. The receiver output signal is 2-phase sinusoidal with a wavelength of $20\ \mu\text{m}$, identical to the pitch of the grating graduations, and is electrically converted to 2-phase square-wave signals by the interpolation circuit. The much smaller working resolution is achieved by detecting the cyclic variation in light intensity incident on the receiver array, as the scale is displaced in a measuring direction, and interpolating accordingly to output a corresponding displacement value.

Detecting Principle Added to AT715

The Absolute system-type linear scale AT715 employs a unique, Mitutoyo-proprietary, electromagnetic induction principle that is highly resistant to environmental contamination. Achievement of a complete absolute scale with a resolution of $1\ \mu\text{m}$ thanks, to a multi-track configuration, enables the user to obtain absolute positional information from the scale immediately power is applied to the counter.

- If time-varying current I_1 is applied to coil A, a magnetic flux is generated inside the coil.
- A current I_2 is induced in coil B that tends to oppose the build-up of the magnetic flux.

The magnetic permeability between the coils will not vary whether the medium is air, water, or oil.

The electromagnetic induction type sensor has excellent water resistance and oil resistance.

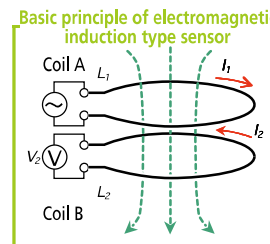

Operating Principle of Electromagnetic Induction Type Encoder

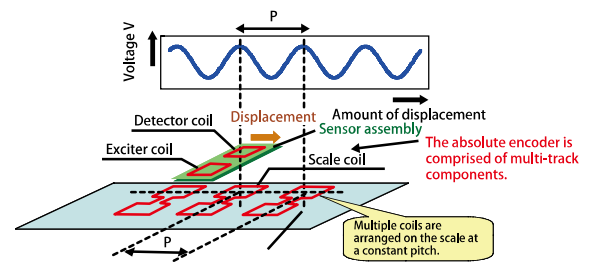

Scale systems for various multi-axis machine tools

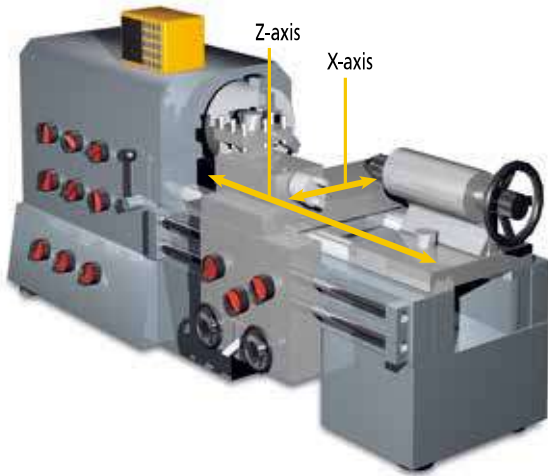

2-axes KA-200 Counter + two scales

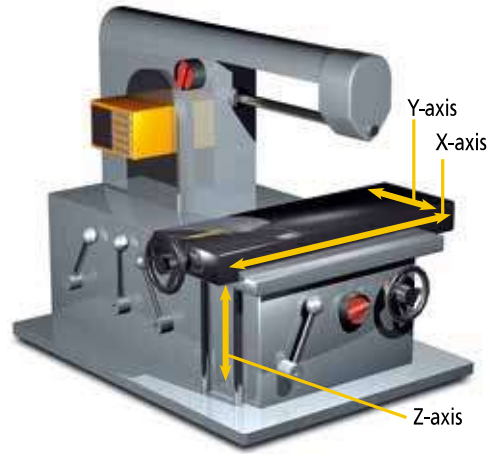

3-axes KA-200 Counter + three scales

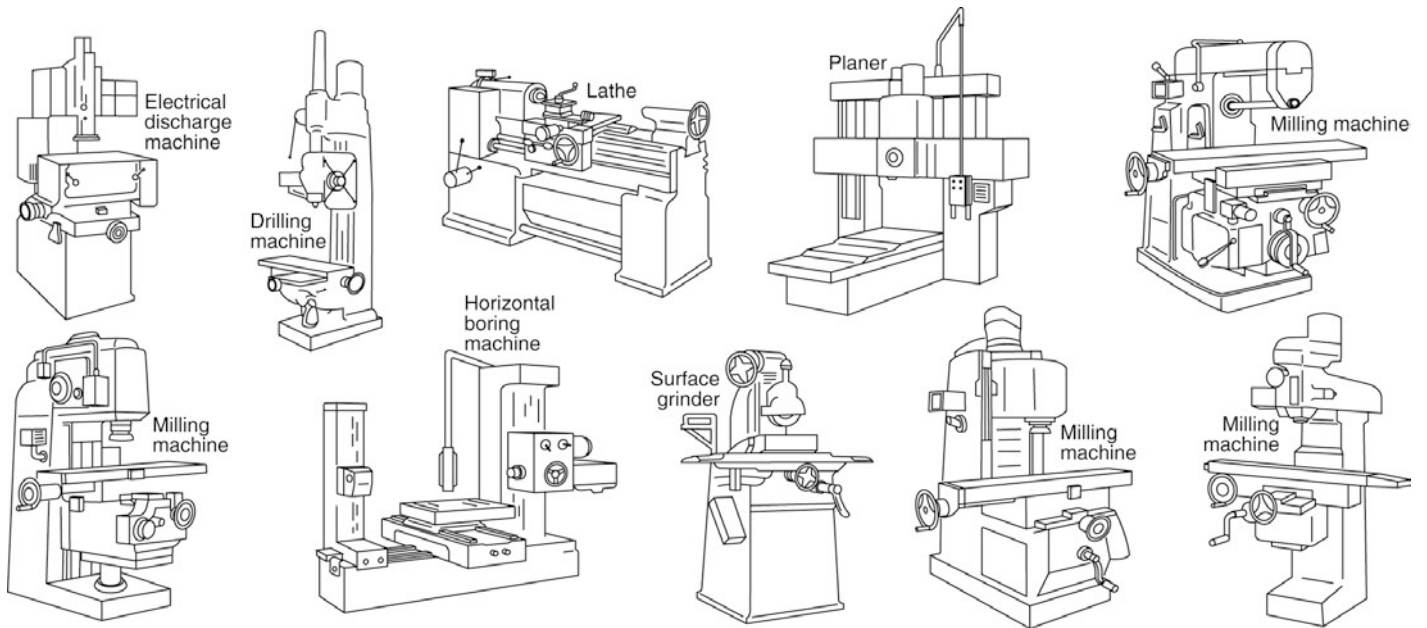

Applications

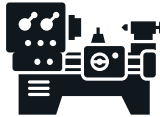

Whatever your challenges are, Mitutoyo supports you from start to finish.

Mitutoyo is not only a manufacturer of top-quality measuring products but one that also offers qualified support for the lifetime of the equipment, backed by comprehensive services that ensure your staff can make the very best use of the investment.

Apart from the basics of calibration and repair, Mitutoyo offers product and metrology training, as well as IT support for the sophisticated software used in modern measuring technology. We can also design, build, test and deliver measuring solutions and even, if deemed cost-effective, take your critical measurement challenges in-house on a sub-contract basis.



Find additional product literature and our product catalog

www.mitutoyo.com

Note: All information regarding our products, and in particular the illustrations, drawings, dimensional and performance data contained in this printed matter as well as other technical data are to be regarded as approximate average values. We therefore reserve the right to make changes to the corresponding designs. The stated standards, similar technical regulations, descriptions and illustrations of the products were valid at the time of printing. In addition, the latest applicable version of our General Trading Conditions will apply. Only quotations submitted by ourselves may be regarded as definitive. Specifications are subject to change without notice.

Mitutoyo products are subject to US Export Administration Regulations (EAR). Re-export or relocation of our products may require prior approval by an appropriate governing authority.

Trademarks and Registrations

Designations used by companies to distinguish their products are often claimed as trademarks. In all instances where Mitutoyo America Corporation is aware of a claim, the product names appear in initial capital or all capital letters. The appropriate companies should be contacted for more complete trademark and registration information.



Mitutoyo America Corporation
www.mitutoyo.com
 One Number to Serve You Better
 1-888-MITUTOYO (1-888-648-8869)

- M³ Solution Centers:**
- Aurora, Illinois (Headquarters)
 - Boston, Massachusetts
 - Huntersville, North Carolina
 - Mason, Ohio
 - Plymouth, Michigan
 - City of Industry, California
 - Birmingham, Alabama
 - Renton, Washington
 - Houston, Texas