

Gauge Blocks

Square Gauge Block Accessories Set SERIES 516

- To expand the application of square gauge blocks, Mitutoyo offers the Gauge Block Accessories Set.

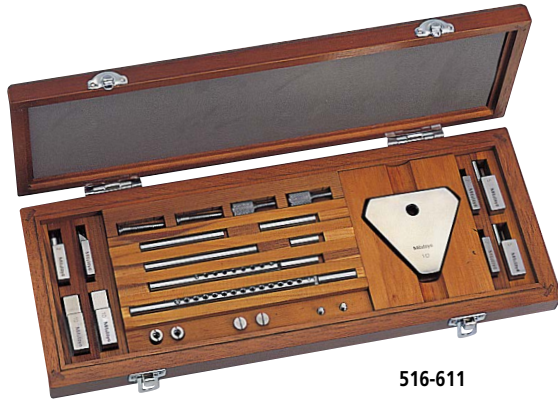

516-611

SPECIFICATIONS

Metric			Inch		
Order No.	Included in set	Quantity Supplied	Order No.	Included in set	Quantity Supplied
619070	Half-round jaw 2 mm	2 pcs.	619050	Half-round jaw 0.125 in	2 pcs.
619071	Half-round jaw 5 mm		619051	Half-round jaw 0.25 in	
619072	Plain jaw 10 mm		619052	Plain jaw 0.5 in	
619073	Center point 2 mm	1 pc.	619053	Center point 0.1 in	1 pc.
619054	Scriber point		619054	Scriber point	
619074	Base 10 mm		619055	Base 0.5 in	
619056	Stud	2 pcs.	619056	Stud	2 pcs.
619057	Flat head screw 1 1/4 in		619057	Flat head screw 1 1/4 in	
619058	Flat head screw 5/8 in		619058	Flat head screw 5/8 in	
619059	Slotted head nut	1 pc.	619059	Slotted head nut	1 pc.
619060	Adjustable tie rod 6 in		619060	Adjustable tie rod 6 in	
619061	Adjustable tie rod 4 1/2 in		619061	Adjustable tie rod 4 1/2 in	
619062	Tie rod 3 in	1 pc.	619062	Tie rod 3 in	1 pc.
619063	Tie rod 2 1/4 in		619063	Tie rod 2 1/4 in	
619064	Tie rod 1 1/2 in		619064	Tie rod 1 1/2 in	
619065	Tie rod 3/4 in	2 pcs.	619065	Tie rod 3/4 in	2 pcs.
619066	Knurled head screw		619066	Knurled head screw	

Note: 2 pcs. of half-round jaw, plain jaw, stud, flat head screw, slotted head nut, adjustable tie rod, and knurled head screw are included in each set. Please note that the abovementioned Order No. indicates only 1 set.

Square gauge block applications

Example of a gage for checking caliper accuracy



Using plain jaws, gauge blocks, a tie rod and a knurled-head screw a gage was constructed to enable rapid checking of the accuracy of a caliper at selected points.

Example of a gage for comparison measurement of a stepped workpiece

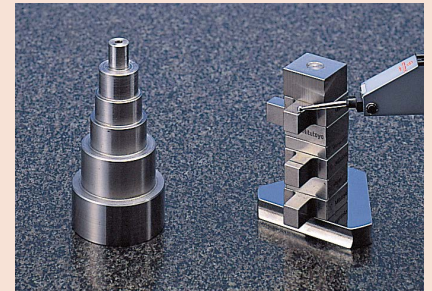

Using plain jaws, gauge blocks, a tie rod and a knurled-head screw a gage was constructed to enable rapid comparison measurement of a stepped workpiece. (Sample workpiece)

Note: Accuracy when using third-party accessories is not guaranteed.

Half-round jaw

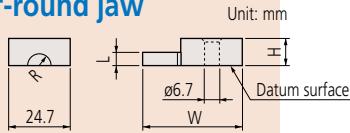

Order No.	R (mm)	L (mm)	W (mm)	H (mm)
619070	1.95	2	33.6	5.3
619071	4.95	5	39.9	10.3

- Flatness 0.5 μm
- Parallelism of L 0.5 μm
- Tolerance of L ±0.5 μm

Plain jaw 619072

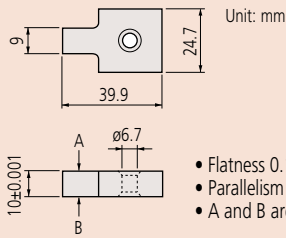

- Flatness 0.12 μm
- Parallelism 0.12 μm
- A and B are datum surfaces

Center point 619073

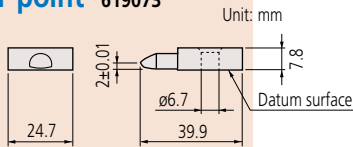

- Flatness 0.5 μm

Adjustable tie rod

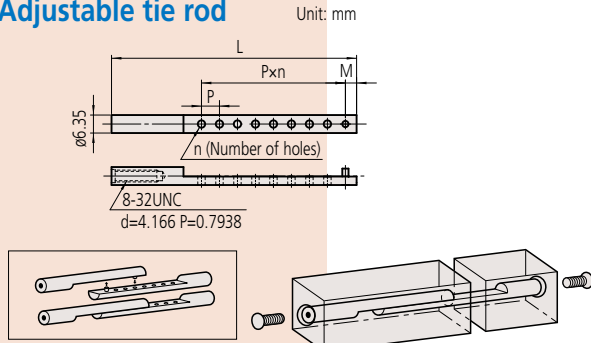

Order No.	L (mm)	M (mm)	P (mm)	n (Number of holes)
619060	124.5	3.85	6.35	14
619061	86.5	3.95	6.35	8

Scriber point 619054

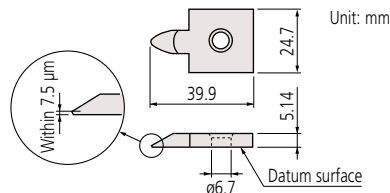

- Flatness of datum surface 0.5 μm

Base 619074

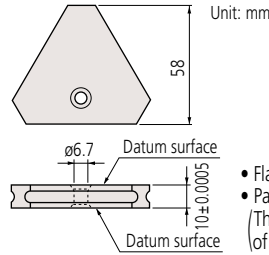

- Flatness 1.5 μm
- Parallelism 1.5 μm (The surface within 1.5 mm) of edge is excluded

Flat head screw

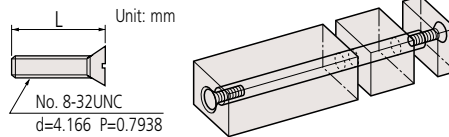

Order No.	L (mm)
619057	31.6
619058	15.8

Stud 619056

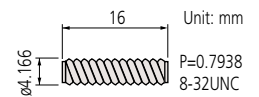

Slotted head nut 619059

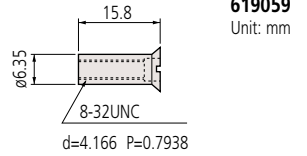

Knurled head screw 619066

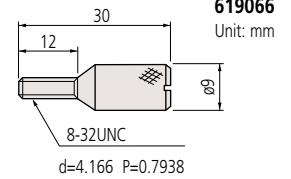

• Contraction caused by the clamping force

The minimum recommended torque to be applied to the clamping screws is approximately 600 mN·m. The chart below shows the approximate length contraction of a 100 mm gage stack using typical torque values.

Driver	Contraction
Torque Driver 600 mN·m	0.2 μm/100 mm
Ordinary Driver 700 to 800 mN·m	0.3 μm/100 mm

Tie rod

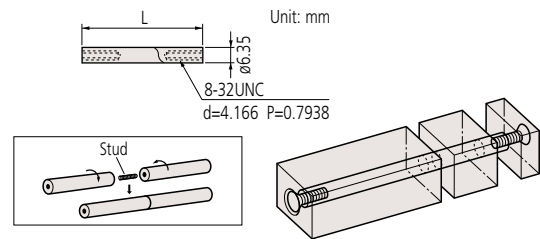

Order No.	L (mm)
619065	19
619064	38
619063	57
619062	76

Accessories used for combining square gauge blocks

Order No.	Overall length (mm) Included in set	Min.	21	36	34	41	45	58	64	72	77	82	91	95	109	117	130	148	121	167	143	160	205	180	223	240	258	295	375	
619059	Slotted head nut	Max.	30	43	43	50	60	72	79	88	91	97	107	109	125	135	150	169												
619058	Flat head screw																													
619057				1																										
619056	Stud																													
619065																														
619064	Tie rod																													
619063																														
619062																														
619061	Adjustable tie rod																													
619060																														