

Height Gage

Height Gage Optional accessories for height gages

Scriber DIMENSIONS

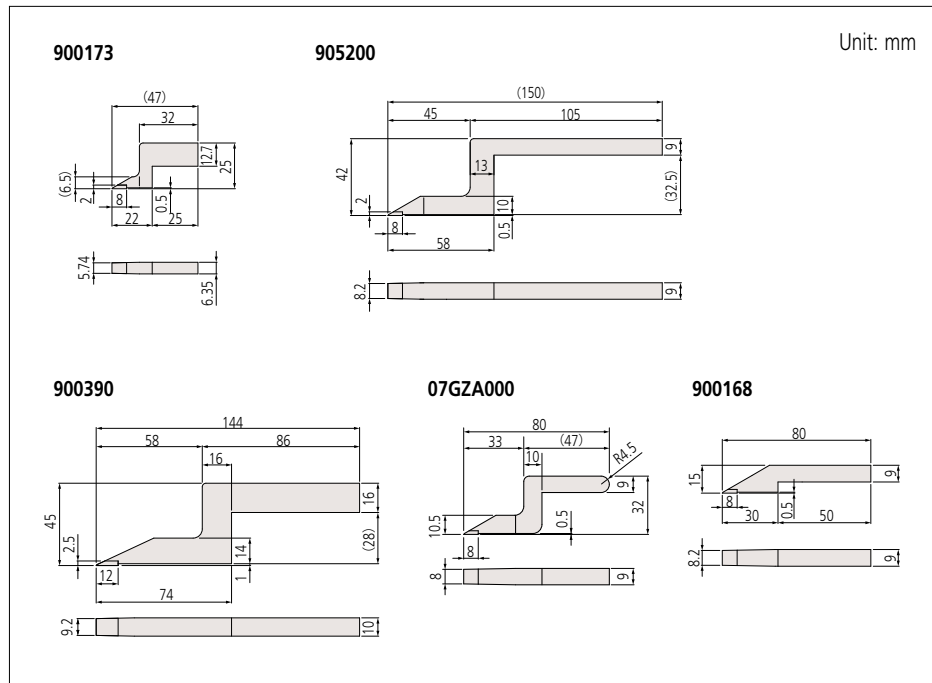

SPECIFICATIONS

Metric	
Order No.	Applicable Height Gages
07GZA000	192 Series Digimatic Height Gages (192-613-10, 192-614-10, 192-615-10)
	570 Series Digimatic Height Gages (570-302, 570-304)
	192 Series Dial Height Gages (192-130, 192-131, 192-132, 192-133)
	514 Series Vernier Height Gages (514-102, 514-104, 514-106, 514-103, 514-105, 514-107)
	574 Series Heightmatic (574-112-1, 574-111-1, 574-110-1)
900168	514 Series Vernier Height Gages (514-160/172)
905200	192 Series Digimatic Height Gages (192-663-10, 192-664-10, 192-665-10)
	570 Series Digimatic Height Gage (570-230)
900390	514 Series Vernier Height Gage (514-170)
Inch	
Order No.	Applicable Height Gages
900173	570 Series Digimatic Height Gages (570-227, 570-244)
	506 Series Vernier Height Gages (506-201/207/204, 506-208)
900258	192 Series Digimatic Height Gages (192-630-10, 192-631-10, 192-632-10, 192-633-10)
	570 Series Digimatic Height Gages (570-412, 570-413, 570-414)
	574 Series Heightmatic (574-212-1, 574-211-1, 574-210-1)
905201	192 Series Digimatic Height Gages (192-670-10, 192-671-10, 192-672-10, 192-673-10)
	570 Series Digimatic Height Gage (570-248)

Dial Test Indicators

- For information about the attachment of test indicators, refer to page F-75.

Contact Sensor



900872

- Attached to both the workpiece*¹ and height gage*² when measuring heights using a height gage with a scribe, the contact sensor is a convenient detector that gives a lamp display when the scribe touches the workpiece.
 - *1 Conductive workpieces only.
 - *2 Attach to a conductive part.
- Magnet is incorporated.
- Battery (PR44, 2 pcs. required) is not included.
- For precision Black Granite Surface Plates, refer to page E-47.

Center Probe

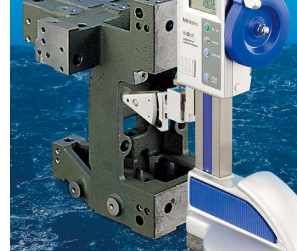

951144

- Allows quick measurement of center-to-center distance between holes.
- Measurable hole diameters: 1 to 38 mm
- Mounting bar section: 9x9 mm

Depth Gage Attachment



900764

- Attaches to a height gage for measuring groove and hole depth.
- Minimum hole diameter: 5.5 mm
- Maximum distance from the bottom of the holding bar to the contact point: 80 mm (metric type), 2.95 in (inch type)
- Dial indicator contact points are usable. (Refer to pages F-57 and F-58.)
- Mounting bar section: 9x9 mm
- Holding bar length: 100 mm