

ROLS/ROLS24

Remote Optical Laser Sensors

Features:

- Speed range up to 250,000 RPM
- Visible red laser light source
- Green LED On-Target Indicator
- 303 stainless steel housing is non-magnetic and not hardenable by heat treatment
- Extremely versatile sensor
- Working distance up to 25 feet from the target
- Maximum offset angle of 60°
- Five (5) models to choose from

Common Usage:

- Wide range of long distance speed measurement applications up to 25 feet



The Remote Optical Laser Sensor (ROLS) has a visible red laser light source and green LED On-Target Indicator. The class 2 laser source acts as the aiming device during setup and can accurately measure speeds from 1-250,000 RPM from a distance of up to 25 feet with a maximum offset angle of 60 degrees from the rotating object. The sensor is housed in a threaded 303 stainless steel tube and supplied with a 90-degree mounting bracket and jam nuts. The sensor is available in the following configurations:

Model	Power Requirement	Cable Length	Cable Termination
ROLS-P	3.3 - 15 V dc	8 feet	1/8 in. [3.5 mm] male stereo plug
ROLS-W	3.3 - 15 V dc	8 feet	tinned wires
ROLS-P-25	3.3 - 15 V dc	25 feet	1/8 in. [3.5 mm] male stereo plug
ROLS24-W	24 V dc \pm 10%	8 feet	tinned wires
ROLS24-W-25	24 V dc \pm 10%	25 feet	tinned wires

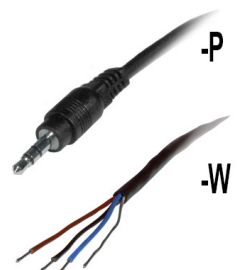

ROLS/ROLS24 Remote Laser Optical Sensors

Specifications*	ROLS	ROLS24
Speed Range	1-250,000 RPM	
Illumination	Visible Red Laser, Class 2	
Laser Specifications:		
Classification	Class 2 (per IEC 60825-1:2014) This product complies with IEC60825-1 Ed. 3 and 21 CFR 1040.10 and 1040.11 except for deviations pursuant to Laser Notice No. 50 of June 2007	
Max Laser Output	1 mW max	
Pulse Duration	Continuous	
Laser Wavelength	650 nm (visible red)	
Beam Divergence	< 18 mrad	
Beam Diameter	4 x 7 mm typical at 2 m	
Laser Diode Life	8,000 operating hours MTBF (1-year warranty)	
On-Target Indicator	Green LED on wire end cap	
Operating Range	Up to 25 feet [7.6 m] and 60° offset from target	
Power Requirement	3.3 - 15 V dc, 0.4 W max	24 V dc ±10%, 0.4 W max
Output - Standard	Open collector with internal pull up resistor to supply voltage; positive pulse when target present - Output Voltage = Supply Voltage	Open collector with internal pull up resistor (5600 ohms) to supply voltage minus ~5 V; positive pulse when target present
Output - Optional	TTL pulse, negative pulse, open collector with internal pull up resistor (4700 ohm) to 3.3 V – 25 mA max load (contact factory)	
Operating Temperature	14 °F to 158 °F (-10 °C to 70 °C)	
Humidity	Maximum relative humidity 80% for temperature up to 88 °F (31 °C), decreasing linearly to 50% relative humidity at 104 °F (40 °C)	
Connection	1/8 in. [3.5 mm] male stereo plug or tinned wires	Tinned wires
Cable Length	8 ft. [2.4 m] or 25 ft. [7.6 m]	
Material	303 stainless steel supplied with two M18 jam nuts and mounting bracket	
Lens	Acrylic plastic	
Dimensions	Threaded tube 3.12 in. x 0.71 in. diameter [M18 x 1.5 x 79.4 mm]	

*Specifications are subject to change without notice.

Ordering Information

Model	Description	Part No.
ROLS-W	Sensor w/8 ft. cable with tinned leads, mounting bracket and 12" of T-5 tape	6180-030
ROLS24-W	Same as above with 24VDC input power	6180-035
ROLS24-W-25	Same as above with 25 ft. cable with tinned leads	6180-035-25
ROLS-P	Sensor w/8 ft. cable, 1/8" phone plug, mounting bracket and 12" of T-5 tape	6180-029
ROLS-P-25	Same as ROLS-P, with 25 ft. cable	6180-029-25

Accessories available on website

Dimensions:

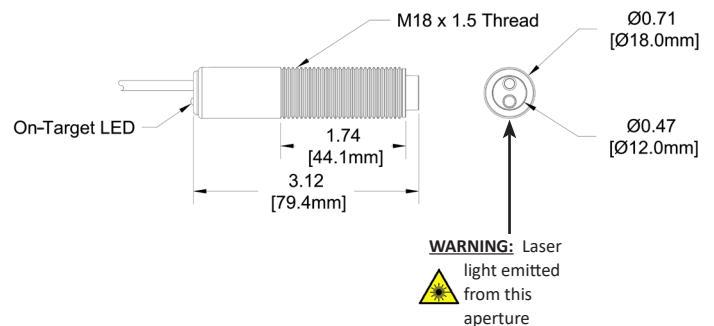

ROLS 0222



15 Columbia Drive, Amherst NH 03031
800-999-3390 // 603-883-3390 // Fax 603-886-3300
sales@monarchinstrument.com

www.monarchinstrument.com