



## Monitoring Green Roof Performance with Weather Stations



## Introduction

In the world of environmentally sensitive and sustainable building, green roofs are becoming more popular in new construction and renovation projects. The investment in covering a roof with soil and plants can pay off through mitigating stormwater runoff, offsetting interior heating and cooling costs, dramatically increasing roof membrane life, and reducing the urban heat island effect.

In order to verify that a green roof is indeed providing the benefits to justify the investment, it's important to monitor performance. For building projects participating in the Leadership in Energy and Environmental Design (LEED®) Green Building Rating System®, documentation of green roof performance is a requirement.

Data logging weather stations are the ideal tools for documenting green roof performance. A weather station can measure weather parameters such as rainfall, stormwater runoff, temperature, relative humidity, wind speed, solar radiation, and a host of non-weather parameters such as soil moisture on a continuous basis (say every five minutes, hourly, or an interval appropriate to the situation). For the purpose of this discussion, “weather station” may refer to a data logger that measures and stores data from weather sensors. The information a weather station collects can help you make wise choices about designing, tuning, and maintaining a green roof.

This guide will explain how a weather station can be a valuable component of a green roof project, and will share information particular to this type of application.

## Green Roofs

A green roof is a roof covered with layers of synthetic and natural drainage layers, soil, and growing plants. The roof's base structural support is typically covered with insulation, waterproofing membrane (with an optional but recommended leak detection system), drainage space, a filter membrane, a root barrier, and finally, soil and plants. Most green roof projects are installed on flat roofs.

Green roofs are broken into two categories by soil depth and plant type. Extensive green roofs are covered in soil one to six inches deep, and are planted with shallow-rooted, drought-tolerant, low-growing plants such as Sedum succulent species. Such roofs may or may not be designed for pedestrian traffic. Intensive roofs have a deeper soil layer, and can support a more diverse and larger-statured plant community that may include shrubs and even trees. Intensive roofs are often part of rooftop terraces or parks, and can require irrigation and dedicated landscape maintenance.

## Benefits of investing in green roofs:

- Green roofs help in stormwater management by withholding or slowing water from drainage systems, thus reducing the burden on infrastructure and runoff treatment capacity. A portion of rainwater is held in the soil, taken up by plants, and returned to the atmosphere as water vapor via evaporation and transpiration. A green roof can eliminate or lessen the need for rooftop stormwater detention tanks.
- Green roofs help mitigate the heat island effect. Typical black-membrane and asphalt roofs absorb solar radiation that raises the temperature above buildings, and in urban and suburban areas in general. Green roofs are covered with soil and green plants, which absorb much less solar radiation than do dark-colored roofs. The plants and soil also release water vapor; evaporative cooling helps in summer months to reduce heat infiltration into buildings and helps cool the surrounding area.
- Building interior heating and cooling costs can be reduced by the use of a green roof. The roofs provide insulation year round from both sun and wind, and in summer months, evaporative cooling combined with insulation remarkably reduces heat infiltration.
- Green roofs can provide outdoor space for building inhabitants or the public, and can offset the loss of green spaces typical in cities. They can also be powerful tools for teaching about sustainable building practices.
- Installation of a green roof can contribute toward satisfying several credits for LEED Certification.

In order to achieve the best possible performance from a green roof, it is best to monitor a range of environmental conditions including rainfall, temperature, wind speed, wind direction, relative humidity, soil moisture, runoff, solar radiation and others. Monitoring and documentation of performance is a requirement for some LEED Certification credits.

The more data you have, the better observations and decisions you can make about your green roof investment.

**Green roofs help mitigate the heat island effect. Typical black-membrane and asphalt roofs absorb solar radiation that raises the temperature above buildings, and in urban and suburban areas in general.**



## Green Roof Monitoring Applications for Data Logging Weather Stations

Below are some approaches for using data logging weather stations to get the most out of your green roof performance and investment. Some of these applications may help satisfy requirements for LEED Certification credits.

### Design

During the preliminary design process, it's prudent to collect environmental data in order to choose the best green roof design suited to the site. Rainfall, temperature, relative humidity, wind speed, wind direction, and solar radiation all change seasonally, and can be affected by surrounding buildings and structures. For retrofits, data collected before renovation can be a valuable measure of the new green roof's performance. The more data you have before you make design decisions, the better.

### Stormwater Management

In order to verify that a green roof is helping to reduce the amount of stormwater released from a roof from a given rainfall event, you must know how much rain has fallen and how much has left the roof via downspouts and drains. In a green roof system, the roof runoff is equivalent to the total rainfall volume minus evapotranspiration and soil retention. There are several approaches to measuring runoff:

1. Direct measurement of runoff using flow sensors at each downspout and/or drain, or using small-scale measurements of drainage and runoff from a microcosm of the roof to measure drainage per unit area (for example, a tipping bucket rain gauge can be adapted to measure flow from a square-foot plot). Whole-roof flow monitoring is ideal, but the mechanics of putting flow meters into downspouts are complicated; the microcosm approach is easier to execute and doesn't have the potential to cause downspout back-ups.
2. Water balance with or without direct measurement of soil water storage. The difference between rainfall and water losses from soils and plants by evaporation (evapotranspiration) represent the drainage from the green roof. Evapotranspiration can be calculated from solar radiation, air temperature, relative humidity and wind velocity at the site – it is important to use evapotranspiration coefficients appropriate to the type and density of vegetation established on the roof. The remaining portion of rainfall volume is retained in the soil, and can be measured/monitored with soil moisture sensors in order to observe where and when the soil is holding water, and for how long. When the maximum water storage of soils (field capacity) has been established by observation, the available soil water storage can be calculated at any time as the difference between field capacity and current moisture content.

3. Runoff from a green roof can be conservatively estimated in a rain event by assuming that rain falling after the monitored soil moisture levels reach their field capacity leaves the roof as runoff. It is important to note that this method will tend to overestimate runoff if the roof drainage layer has absorptive capacity or if succulent plants are actively growing.

### **Heat Island Effect Mitigation**

It is easiest to monitor the before-and-after heat island effects of green roofs on renovated roofs. It's a matter of simply using a weather station and surface temperature sensors to monitor pre-renovation roof temperature over time at several points on and above the roof. Once the green roof is installed, temperature can be monitored at the same points at the same time of year and under similar temperature and solar radiation levels to verify whether or not there has been a substantial change in surface and air temperatures. Note that air temperature differences may be small due to rapid mixing with air moving over the roof; in this case, surface temperature measurements are recommended. For new construction, you could use a weather station on the green roof and compare the temperature data with data from stand-alone battery-powered temperature loggers deployed on nearby surrounding conventional rooftops.

### **Maintenance of Plantings**

Whether a green roof is extensive, with low-growing succulent ground cover, or intensive, with shrubs and diverse, lush vegetation, you can better maintain healthy plant cover if you have ongoing, reliable conditions data. A weather station can monitor soil moisture and rainfall, thus helping to make irrigation decisions, and a station with relay outputs can be used to automatically control an irrigation system. Temperature and wind monitoring can also be important in estimating evapotranspiration and anticipating irrigation needs, thus maintaining the health of rooftop vegetation. For extensive landscaped rooftop gardens, the data gathered by a weather station can be crucial to understanding how to care for rooftop vegetation, where environmental conditions differ from those on the ground.

### **Offset of Interior Heating and Cooling Costs**

A green roof acts as insulation from the sun and wind, and during the growing season provides substantial evaporative cooling. The combination of added insulation and evaporative cooling can reduce a building's interior heating and cooling requirements. In the case of a renovation, you can compare the before-and-after effects by deploying a weather station on the roof and indoor temperature loggers in the building's top floor for a period of time before construction.

**For extensive landscaped rooftop gardens, the data gathered by a weather station can be crucial to understanding how to care for rooftop vegetation, where environmental conditions differ from those on the ground.**

**The data gathered from a rooftop weather station can be made available over the Internet to energy analysts, building occupants, educators/students, and the public to document how a green roof works and how it can help reduce a building's impact on the environment.**

In this case, rooftop measurements should include temperature, solar radiation, and wind speed. Once the green roof is installed, deploy the weather station and indoor loggers in the same or comparable locations at the same time of year the pre-construction data were gathered, and observe how outdoor and indoor conditions correlate with one another before and after renovations.

#### **Education and Research**

Green roofs are growing in popularity, and more and more sustainably-minded builders and building owners want to share their green roof projects with the public. The data gathered from a rooftop weather station can be made available over the Internet to energy analysts, building occupants, educators/students, and the public to document how a green roof works and how it can help reduce a building's impact on the environment. Engineers, researchers and green roof component manufacturers can also use data logging weather stations to develop and test new materials and configurations in order to increase green roof performance in the future.



## Data Logging Weather Stations – An Overview

Data logging weather stations are ideally suited for monitoring a green roof's performance and operating conditions.

A typical weather station consists of a data logger and sensors mounted on a metal tripod or mast. The system runs on battery power or a combination of solar power and a rechargeable battery. Key components include:

- Data logger
- Sensors
- Cables
- Tripod/mast, or other mounting system
- Grounding
- Securing equipment such as guy wires and cable protection

The data logger is the central unit within the weather station. Its primary components are a microprocessor, data input channels, battery, and a weatherproof enclosure. The number of data input channels a particular data logger provides determines how many sensors can be added to the weather station. Durable, weatherproof housing ensures electronic components stay dry and function properly in wet or otherwise harsh outdoor environmental conditions.

Data loggers record and store data collected from sensors at preset intervals. Users retrieve this data by offloading it to a PC or Macintosh computer or a data shuttle transfer device, or by accessing it remotely via the Internet using GSM cellular, Wi-Fi, or other types of remote communications.





## Considerations in Choosing a Weather Station

When searching for a research-grade weather station for your green roof project, here are some things to keep in mind.

### 1. Sensors and Logging Capacity

The first step in thinking about a weather station is to decide what you want to measure, where, and how many of each sensor you will need. For example, would you like to monitor soil moisture content at four locations on your green roof? Then you'll need four soil moisture sensors. Each sensor you use requires a data channel at the logger, and weather station loggers have different capacities, depending on the model and manufacturer. Some weather stations allow for the use of third-party sensors, so if this flexibility is important to your application, shop around.

### 2. Configuration and Setup

While some data logging weather stations can be difficult to configure and often require the services of a professional system integrator for set up, many of today's advanced systems do not require programming or complex wiring. Instead, these systems leverage "Smart Sensor" technology, which provides the user with "plug-and-play" performance: once a sensor is plugged into the data logger, it is automatically recognized and can begin taking measurements. This type of system architecture can significantly reduce set up and deployment time, and reduce or eliminate the need for specialized integrator assistance.

### 3. Data Download

Decide whether you want to download or view data through the Internet or offload data with a laptop or data shuttle. Most systems with Internet compatibility can also be offloaded with a laptop as a backup. Web-based weather stations provide near real-time data that may be used to make timely management decisions, and also allows rapid response to sensor failures that could go undetected between manual data downloads.

### 4. Software

Chances are you'll want to work with your data, whether to enter it into models, or simply present the information clearly in a graph. Weather station software capabilities vary, but you'll want to look for an application that allows you to combine graphs to compare data, or to view all of a site's data clearly in a single graph.

### 5. Cost and Support

Data logging weather stations can range in cost from several hundred to several thousand dollars. Additionally, hardware and accessories such as a tripod and various sensor shields can add up. Ask colleagues about their experiences, and get a feel for how willing a manufacturer is to help you with your green roof application



## Weather Station Deployment Tips

Once you've received all hardware and software, do a dry run and connect the sensors to the data logger in the office to ensure everything is in good working order and to familiarize yourself with the components. When you're ready to assemble the weather station, stay organized and build as much of it indoors as possible - this reduces the chance of losing important small parts. At the site, lay down a tarp and place all tools and components on top.

### Tripod/Mast Setup and Placement

Users typically use a tripod when deploying their weather stations, and mount sensors either on the tripod or run cables to nearby locations. For green roofs, however, using stakes or rebar driven into the soil to secure the tripod is not possible. Ideally, attach a mast securely to a side wall and attach a cross arm to the mast. In any case, consult with the project roofer or roofing consultant to avoid roof damage that could jeopardize the roof integrity or warranty; for example, be sure to include adequate ballast and to protect the roof from abrasion using heavy duty polyester felt, carpet, or other materials approved by the building roofing consultant. If your installation includes guy wires, flag them so people don't walk into them.

Some users mount sensors on the upper mast of the tripod before it is attached to the lower mast. This makes it easier to attach the sensors. To do this, stand the upper mast upright and use zip ties to attach it to one leg brace and one leg of the tripod. Once the cross arm and sensors are installed, remove the zip ties and place the upper mast on top of the lower mast. Then make final sensor height adjustments and leveling.

The data logger should be mounted on the mast so that the cables come out the bottom of the logger. This enables them to hang down, which prevents water drops on the cables from entering the logger. If the logger has a vent, be sure the vent is oriented per the vendor's recommendation to properly ventilate. For example, a Gore® vent must be on a vertical side of the logger.

### Sensor Placement

Once the weather station is suitably placed, sensors need to be properly positioned to gather accurate measurements. Here are some general tips for positioning sensors, and the following table shows recommendations specific to certain sensors:

- To better account for spatial variability, for critical parameters such as rainfall, attach two or more identical sensors on the same weather station. Place one on the tripod/mast and the other several feet away.
- In general, avoid placing sensors near radio, television, or microwave towers and equipment. Strong electromagnetic interference may cause reading errors.
- To avoid fatal shock, do not set up weather stations near power lines.

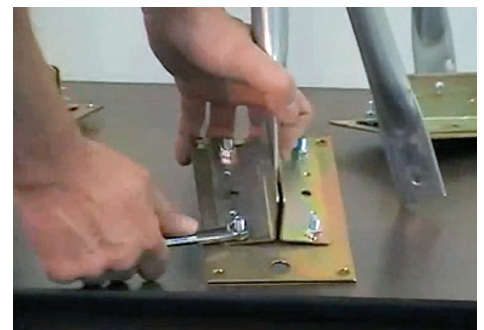
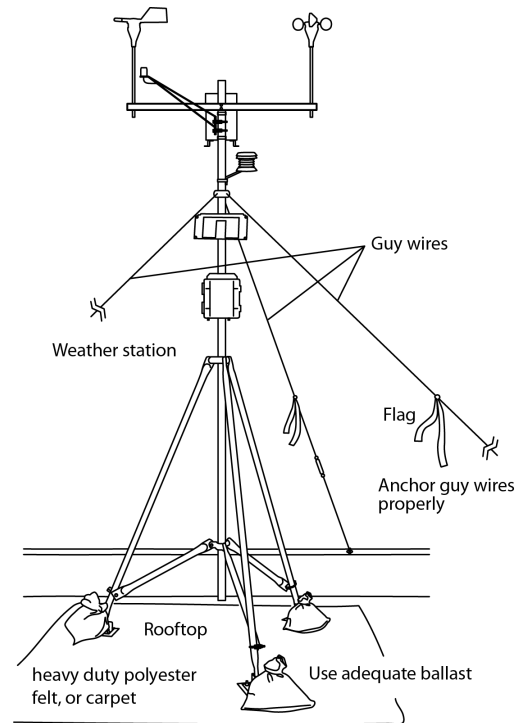

Partial assembly of a weather station indoors can help reduce the loss of small parts in the field.



Sensor	Positioning
Wind speed and wind direction	Attach to the top of the upper mast and set the wind direction sensor to read 0 or 360 degrees when pointing north.
Soil moisture	Consider the soil moisture sensor's volume of influence. Since the soil layer of a green roof is often thin, choose a sensor with a small enough volume of influence so it will only measure soil moisture and not that of the surrounding air or underlying roof drainage layer. Set soil sensors far enough away from the tripod or mast to avoid being in its shadow, and backfill the hole with the same soil density as surrounding soil. Separate soil moisture sensors by minimum distances recommended by the manufacturer to avoid electric field interference between sensors.
Rainfall	Be sure that rain gauges are mounted in a manner such that they are level, free from vibration in high wind, and at locations where they can be inspected and serviced (e.g., checking for accumulation of dirt in the funnel). For ground-mounted rain gauges, the legs of the rain gauge can be attached to paving stones with Tapcon cement screws. Larger paving stones provide a small zone of vegetation exclusion; you may want to extend the non-vegetated zone further to help prevent rainfall from being blocked by overhanging vegetation and leaf debris.
Leaf wetness	Mount as close to plant canopy as possible. However, position far enough away from trees so plant leaves do not touch the sensor. This will also help sensors avoid coming in contact with chemical plant sprays.
Solar Radiation	Mount on a mounting arm or bracket on the south side of the mast if in the northern hemisphere so that it will not fall into the shade of the mast or other sensors. Point sensor up and properly leveled.
Roof runoff	Runoff from conventional roofs can be approximated from rainfall measurements (assuming 100% runoff). Direct measurement of runoff can be achieved by using flow sensors at each downspout and/or drain, or by using small-scale measurements of drainage and runoff from a microcosm of the roof to measure drainage per unit area (for example, a tipping bucket rain gauge can be adapted to measure flow from a square-foot pan lysimeter within a roof microcosm). As stated previously, whole-roof flow monitoring is ideal, but the mechanics of putting flow meters into downspouts are complicated; the microcosm approach is easier to execute and doesn't have the potential to cause downspout back-ups. Microcosms should be designed to reduce errors due to edge effects or divergence around pan lysimeters.
Barometric pressure	Use weatherproof barometric pressure sensors and mount outside of logger enclosure, since enclosure seals and vents can cause pressure inside housing to differ. The height of the barometric sensor is not a factor.

### Sensor Cable Protection

Users often cover cables with conduit, and protect cables buried in the ground as well. Use a plumber's snake to pull wire and cables through conduit. Rain gauges also need protection, as birds like to build nests inside these inviting resting spots. Attach spikes around the rain gauge to deter birds.

### Proper Grounding

Proper grounding of a weather station is advisable, as it provides protection from electrical interference and thus can help minimize the chance of system failures in the field. On a rooftop, connect the ground wire to an AC unit chassis that is properly grounded. If there is no suitable ground, then run a ground wire to a ground rod in the ground outside the building. An eight-foot ground rod is recommended, but a four-foot ground rod is often sufficient.

### Battery Maintenance

Weather station data loggers are typically powered by either regular batteries or rechargeable batteries recharged via solar panel. If the weather station is sited near the equator (e.g., Southern U.S.), a one-watt solar panel may generate enough power to sufficiently charge batteries. However, if the same weather station is farther away from the equator (e.g., Northern U.S.), then a six-watt solar panel may be necessary due to the fewer daylight hours at certain times of the year. In some climates, even a high-wattage solar panel is not enough to keep a rechargeable battery going in the winter, especially in fog. In this case, you will need additional batteries for backup. As a general rule, replace rechargeable batteries every three to five years and regular batteries once a year. However, battery life depends on logging intervals. For example, with some weather stations, if the logging interval is set to faster than one minute, the batteries might only last 30–50 days. If the interval is set at one minute, the batteries should last one year. Furthermore, make sure the batteries' "use before" dates are at least two years from the current date.

### Calibration

In some cases, sensors will require calibrating before the deployment is started, and periodically during deployment. Rain gauges may need to be checked and calibrated. First, make sure that dirt, cobwebs, etc., have not accumulated in the tipping bucket assembly and that the rain gauge funnel is not blocked with debris. Calibration can be performed in the field by slowly introducing water into the gauge at a controlled rate and checking that the correct amount of this simulated rainfall is recorded. Adjust rain gauge screws until it provides the correct reading.

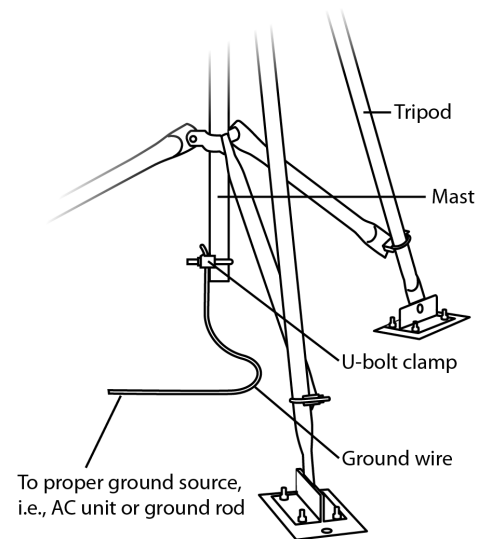
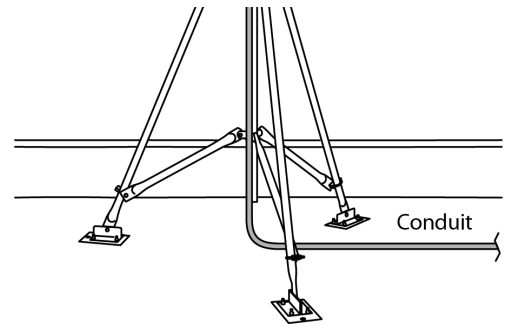

## Other informational resources available from Onset:

### Deploying Weather Stations: A Best Practices Guide

From the tropics to the poles, climate, agriculture and other researchers rely on unattended research-grade, data logging weather stations. For example, the US Department of Agriculture uses weather stations to study anything from molecular plant pathology to forest management. Non-government groups, such as universities, use weather stations to study a wide array of subjects including how glacial activity affects air temperature. Additionally, commercial companies depend on weather stations to conduct businesses.

Our new best-practices guide, Weather Station Deployment Techniques, shares field-proven tips and techniques for installing research-grade weather stations in the field. A range of topics are discussed, including weather station site location, sensor placement, system configuration, and cable protection.

### Monitoring Wetlands with Data Loggers: A Best Practices Guide

Wetlands act as a natural filter for polluted water and thus play an essential role in water quality protection. They serve as floodwater storage to help minimize erosion, and create a habitat for many fish and wildlife.

While a variety of factors have decreased the number of wetlands in the U.S. by half since 1950, many organizations are restoring wetlands back to their original flourishing ecosystems. To ensure success, it is necessary to monitor wetland factors such as water level, temperature, and rainfall.

This guide shares field-proven best practices for configuring, launching and deploying portable data loggers in wetland monitoring applications. A range of data logger types is covered, and tips are provided on logger installation and maintenance.

### Monitoring Geothermal Heat Pump Performance

This paper discusses how portable data logging technology can be used to measure, record, and document the performance of geothermal heat pumps, and provides specific case study examples of how the technology is being applied in geothermal system monitoring applications.

### Wind Resource Site Assessment: A Guide to Selecting Monitoring Equipment

This paper provides project managers and others involved in small- to moderate-scale wind energy projects with details on how data loggers are used to evaluate wind resources.

It helps simplify the equipment selection process by providing tips and guidance on choosing the right data loggers, sensors and other components for your project.

### Guidelines For Successful Soil Temperature Monitoring

This paper provides guidance and tips on how data loggers can be effectively used to monitor soil temperatures in various conditions.

### Choosing A Data Logging Weather Station: 5 Important Considerations

This paper provides researchers, crop consultants, and growers with valuable tips on how to evaluate data logging weather stations, and provides key factors to look at during the product selection process.

### Weather Stations: Saving Time & Money with Remote Communications

This white paper provides specific information about three ways weather stations with remote communications can save time and money, and helps you decide whether these systems are right for your application.

**Access our full resources library at:**  
**[www.onsetcomp.com/resources](http://www.onsetcomp.com/resources)**

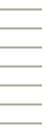

## About Onset

Onset is the world's leading supplier of data loggers. Our HOBO data logger products are used around the world in a broad range of monitoring applications, from verifying the performance of green buildings and renewable energy systems to agricultural and coastal research.

Based on Cape Cod, Massachusetts, Onset has sold more than 2 million data loggers since the company's founding in 1981.

## Contact Us

Our goal is to make your data logging project a success. Our product application specialists are available to discuss your needs and recommend the right solution for your project.



Onset  
470 MacArthur Boulevard  
Bourne, MA 02532

- Speak with an application specialist by calling 1-800-564-4377
- Email your inquiry to [sales@onsetcomp.com](mailto:sales@onsetcomp.com)
- Go to [onsetcomp.com](http://onsetcomp.com) to browse our white papers, application stories, videos, and webinars