

## Study Carrel

Model Numbers: 89788, 89789

### OVERVIEW

The heavy duty Study Carrel provides privacy wherever it is needed. Ideal for libraries, testing areas, or any other place a private work space is required.

### PANELS AND SHELF

All panels comprising back, sides, and work surface are made of 3/4" Particleboard Core with 3mm Flat Vinyl T-Mold Edge. Panels are constructed of 45# particleboard core with high-pressure laminate (HPL) top and bottom surfaces for balanced construction. Edgeband is secured with brad nails along the perimeter. Panels attach to one another at each joint with two cam locks and posts. 10 Ga angled steel brackets reinforce the joints using three woods screws each. 7.8" deep shelf uses same construction as panels and attaches to side panels with four cam posts and to back panel with two angled brackets. Work surface has a single grommet hole and cover for wire management. Carrel panels are available in either oak or gray laminate with white interiors.

### FRAME

All frame components are powder coated in black. Frame feet, leg inserts, and crossbar are constructed from 18 Ga steel rectangular tubing. Leg outers are 14 Ga steel rectangular tubing and fasten to inners with two M5 x 12mm allen screws. Outers are welded to 18 Ga steel tubing pieces that attach to threaded inserts in bottom of desk with two M5 x 42mm allen bolts. Crossbar has 10 Ga steel triangle brackets welded at either end which fasten to leg outers with two M5 x 42mm bolts and nuts. Feet receive two height adjustable glides each. Legs can be adjusted between 22" and 30" for an overall study carrel height range between 38.3" and 46.3".

### CERTIFICATIONS

Indoor Advantage Gold certified.



### OPTIONS/ACCESSORIES

Available with pop-up grommet outlet and USB charger.

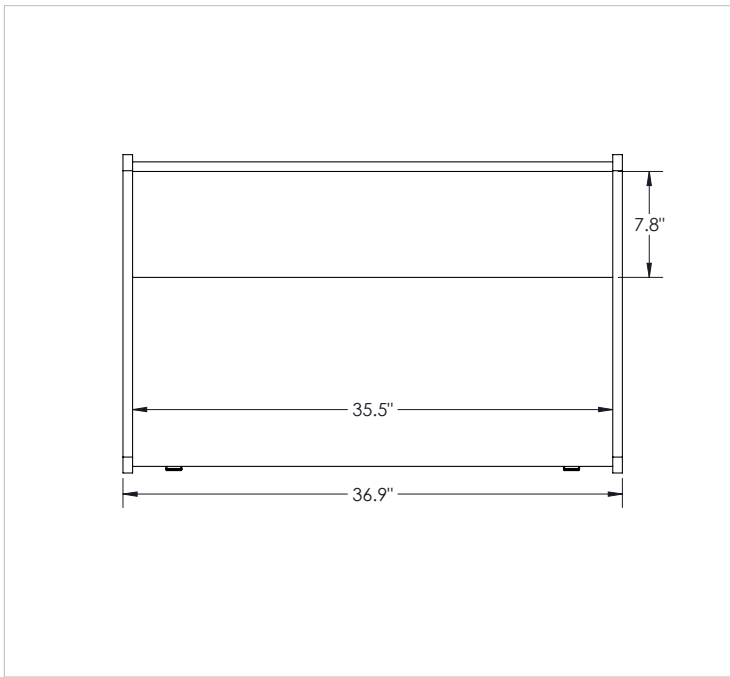
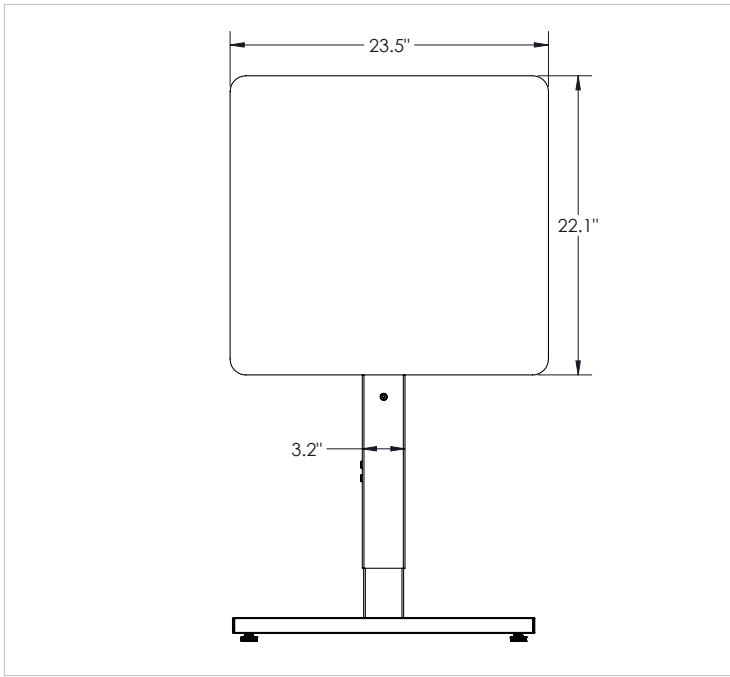
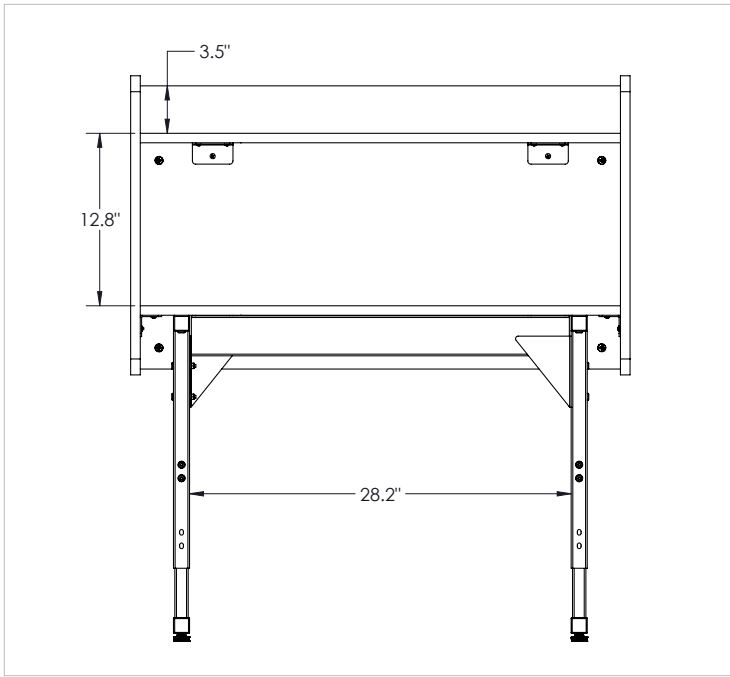

**DIMENSIONS**

Base Model No.	Description	Table Dimensions
89788	Study Carrel - Oak	38.3"-46.3"H X 37"W X 24"D
89789	Study Carrel - Gray	38.3"-46.3"H X 37"W X 24"D

**OPTIONAL ACCESSORIES**

Base Model No.	Description
66666	Pop-Up Grommet Outlet & USB Charger



**MooreCo | Vanerum North America**  
 2885 Lorraine Avenue | Temple, TX 76501  
 p: 800.749.2258 | f: 866.888.7483  
[www.moorecoinc.com](http://www.moorecoinc.com) | [www.vanerumnorthamerica.com](http://www.vanerumnorthamerica.com)