

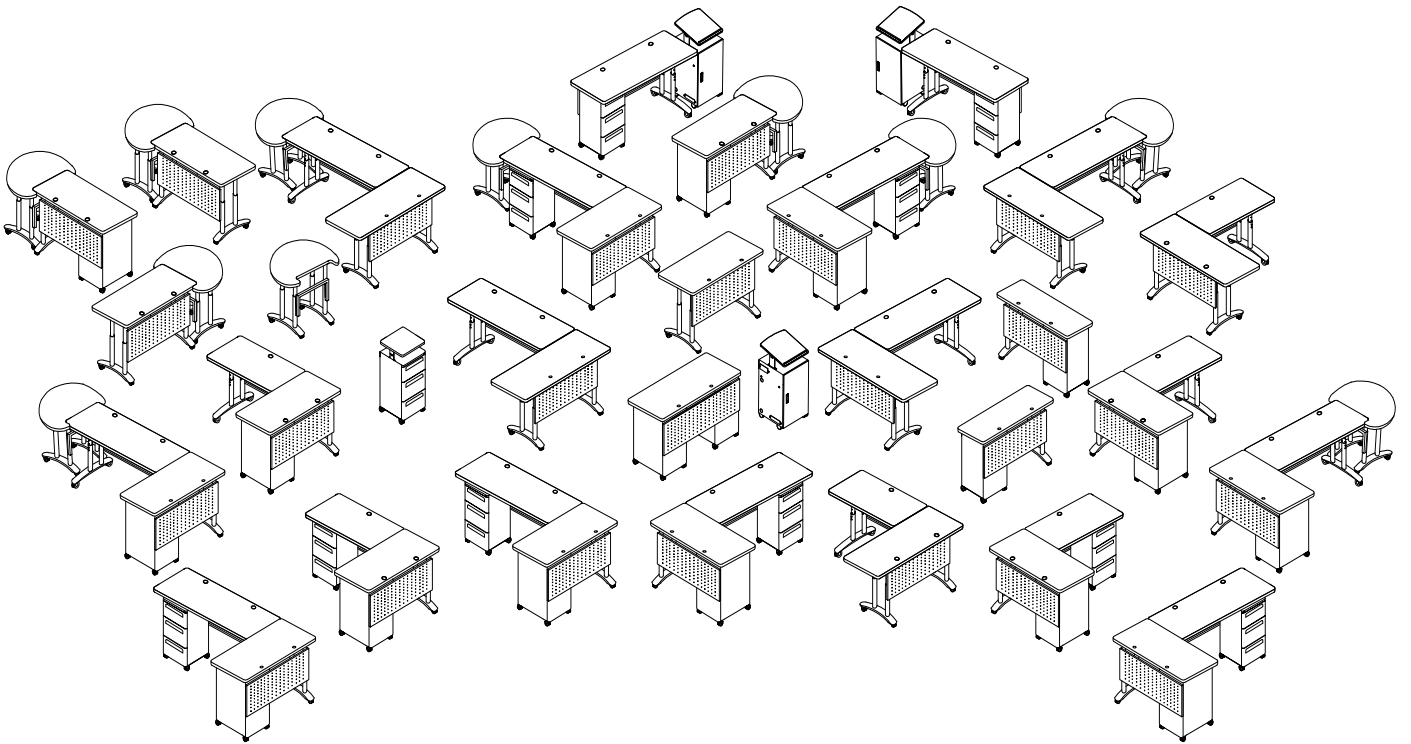





# Modular Teacher's Desk Systems



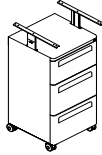

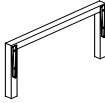
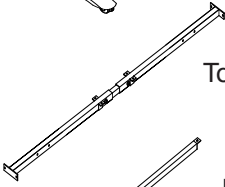
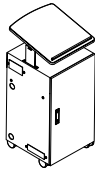
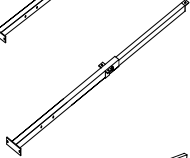
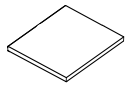
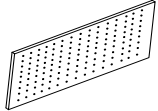
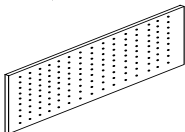
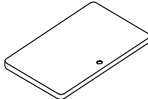
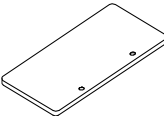
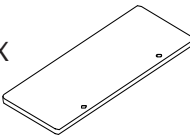





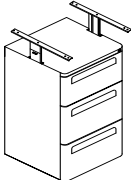







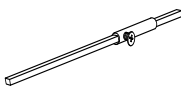







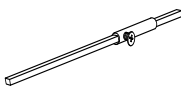



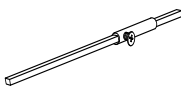

## Assembly Instructions

# Modular Teacher's Desk Components

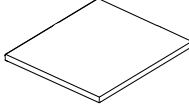
Part	Drawing	Description	Qty	Part	Drawing	Description	Qty
90390		Adjustable Leg-1S		90369		Modular Pedestal	
90391		Adjustable Leg-3S		58260		Leg Support	
58261		Top Support Tube		27694		Trend Podium	
XXXXX		Pedestal Support Tube		XXXXX		Modular Pedestal Top	
58258		Modesty Panel-60"					
58259		Modesty Panel-72"					
XXXXX		Top Panel-48"					
XXXXX		Top Panel-60"					
XXXXX		Top Panel-72"					
XXXXX		1/2 Round Top Panel					

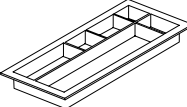
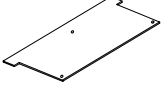
# Modular Pedestal-90369

Part	Drawing	Description	Qty	Part	Drawing	Description	Qty																																				
P-1		Pedestal Box	1 EA	<div style="border: 2px solid black; border-radius: 15px; padding: 10px;"> <h3 style="text-align: center;">Hardware List</h3> <table border="0"> <tr> <td>A</td> <td></td> <td>Screw M6*38mm</td> <td>4 EA</td> </tr> <tr> <td>A2</td> <td></td> <td>Screw M5*25mm -Caster</td> <td>4 EA</td> </tr> <tr> <td>B</td> <td></td> <td>CS 1/4X12mm -V Bracket</td> <td>5 EA</td> </tr> <tr> <td>C 1</td> <td></td> <td>Locking Caster</td> <td>2 EA</td> </tr> <tr> <td>C 2</td> <td></td> <td>Caster</td> <td>2 EA</td> </tr> <tr> <td>D</td> <td></td> <td>Allen Wrench</td> <td>1 EA</td> </tr> <tr> <td>E</td> <td></td> <td>Lock Keys</td> <td>2 EA</td> </tr> <tr> <td>F</td> <td></td> <td>Square Timing Rod</td> <td>1 EA</td> </tr> <tr> <td>G</td> <td></td> <td>Insert Cap</td> <td>4 EA</td> </tr> </table> </div>				A		Screw M6*38mm	4 EA	A2		Screw M5*25mm -Caster	4 EA	B		CS 1/4X12mm -V Bracket	5 EA	C 1		Locking Caster	2 EA	C 2		Caster	2 EA	D		Allen Wrench	1 EA	E		Lock Keys	2 EA	F		Square Timing Rod	1 EA	G		Insert Cap	4 EA
A		Screw M6*38mm	4 EA																																								
A2		Screw M5*25mm -Caster	4 EA																																								
B		CS 1/4X12mm -V Bracket	5 EA																																								
C 1		Locking Caster	2 EA																																								
C 2		Caster	2 EA																																								
D		Allen Wrench	1 EA																																								
E		Lock Keys	2 EA																																								
F		Square Timing Rod	1 EA																																								
G		Insert Cap	4 EA																																								
P-2		Top	1 EA																																								
P-3		Top Support Tube	2 EA																																								
P-4		Tray	1 EA																																								
P-5		Drawer Divider	1 EA																																								
P-6		V Bracket- Inner Not Used on Free Standing Unit	1 EA																																								
P-7		V Bracket - Outer Not Used on Free Standing Unit	1 EA																																								

**READ THROUGH INSTRUCTIONS FROM BEGINNING TO  
END BEFORE STARTING TO ASSEMBLE UNIT.**

- 1.) Identify and Separate all the Parts and Hardware.
- 2.) Attach two Locking Casters (C1) to the front holes on the bottom of Base (P1) by inserting the side tab on the Caster's base into the slot and using one Screw (A2) to secure each. Repeat this step to attach the two Non-Locking Casters (C2) in the bottom rear slots and holes as shown in illustration #1. Tighten Screws with Phillips screw driver.

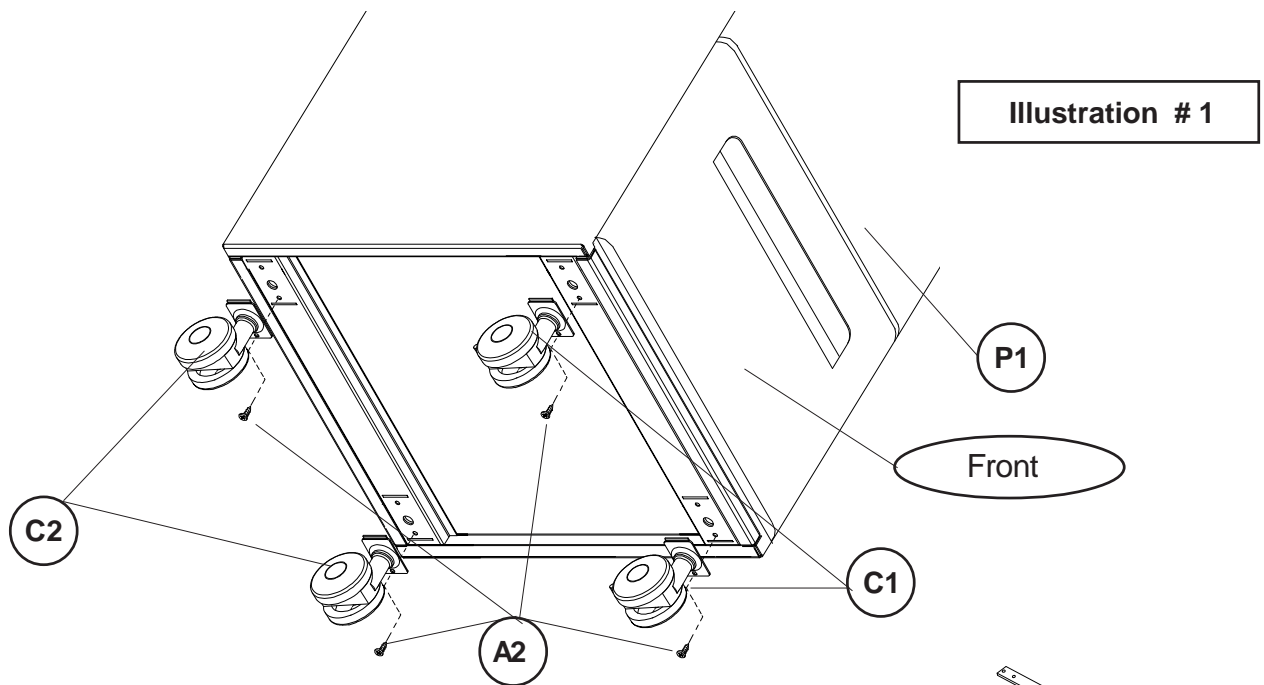

3.) **SPECIAL NOTE:**

If you are going to use your Modular Pedestal under a desk, stop at this point. See illustration #1a.

Illustration # 1a

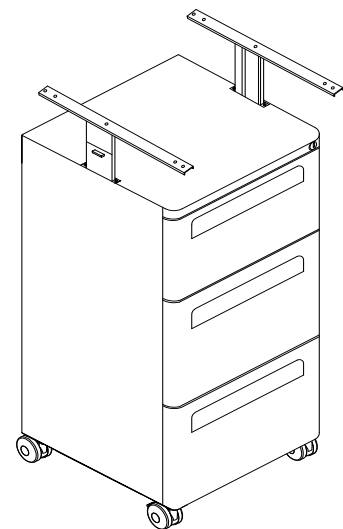

- 4.) Attach the Top (P2) to the Pedestal Box (P1) as shown in illustration #2. Insert two Screws (A) through one Top Support Tube (P3) and Pedestal Box's top mount bracket and into the holes in the bottom of the Top (P2). Repeat this Step to attach the other side.

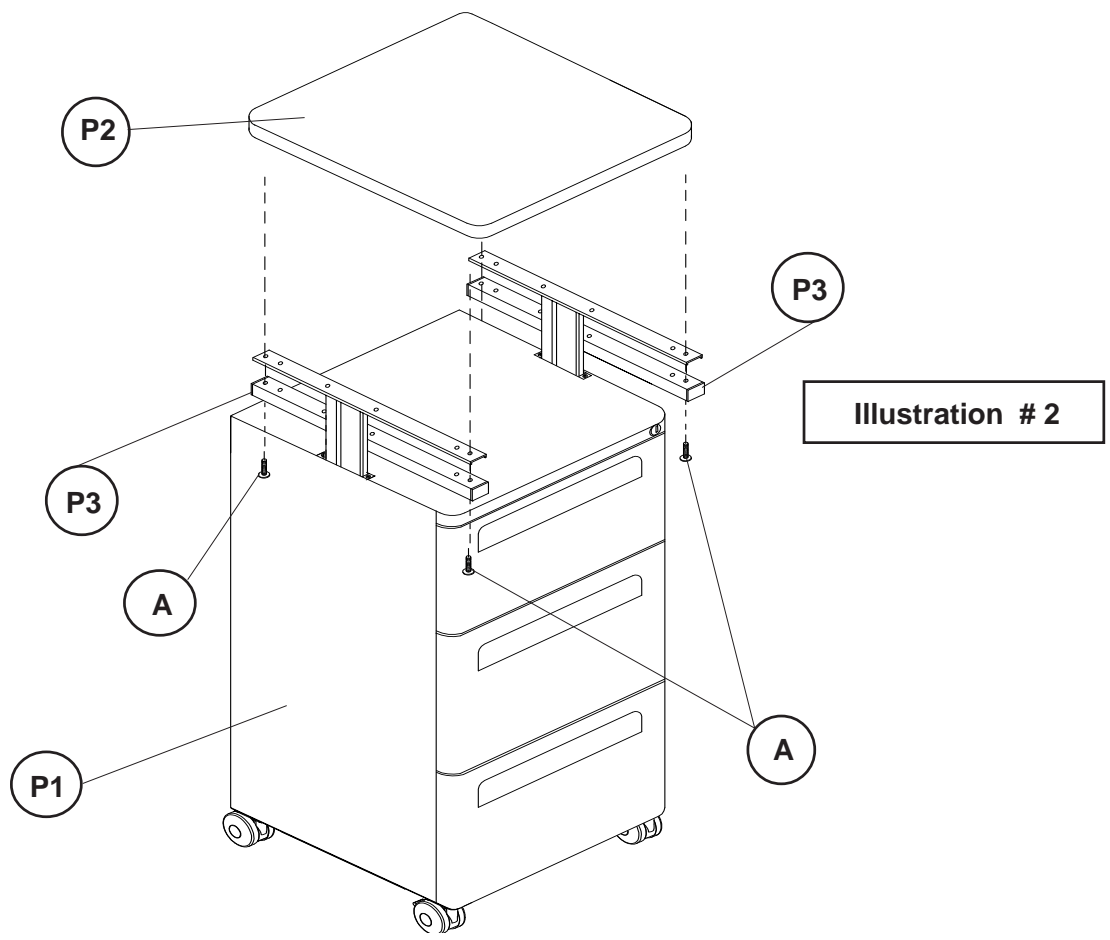

- 5.) Place Tray (P4) and Drawer Divider (P5) into the top or middle drawers of Pedestal Box (P1).

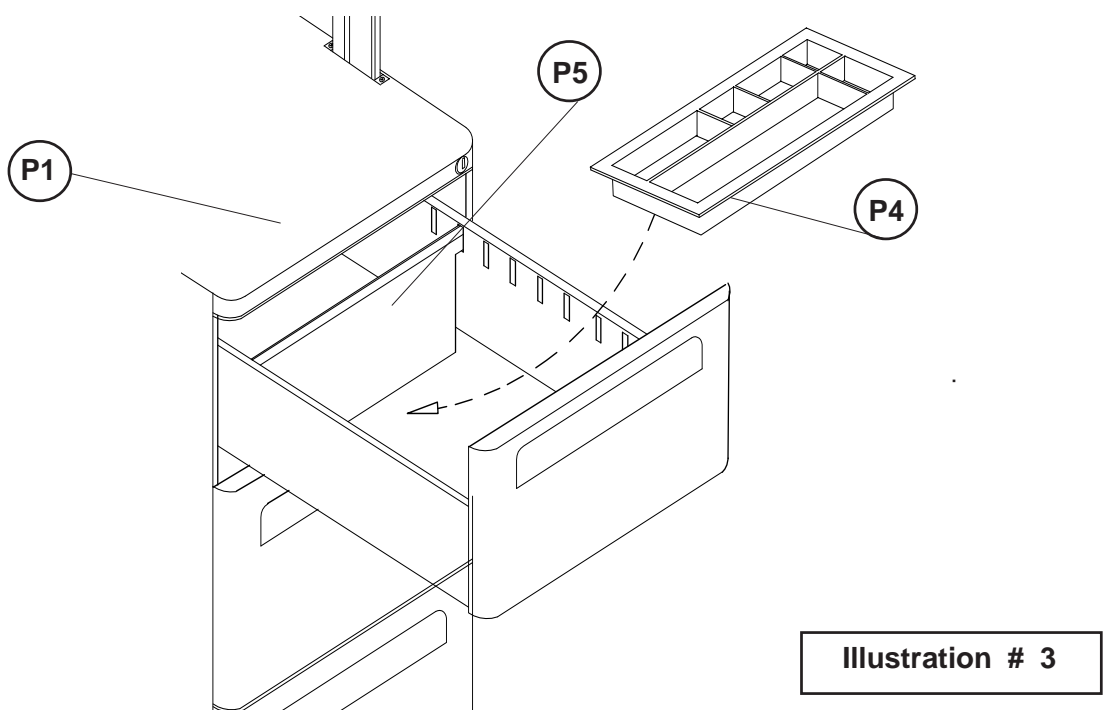

- 6.) Press in four plastic Insert Caps (G) into the holes on the back of the Pedestal Box (P1) as shown in illustration #4.

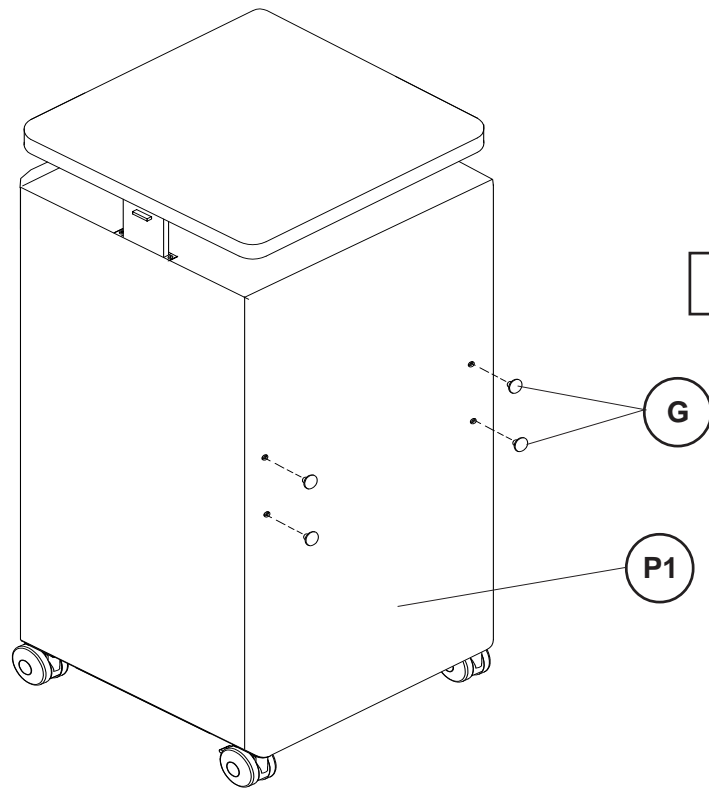

Illustration # 4

- 7.) Raise the podium's top to the highest position by pulling up on the Side Release Tabs.. Open the door to the cabinet and look in the top of the cabinet. Find the square hole recesses at the top of the height adjustment mechanisms. Loosen the screw on the Square Timing Rod (F). Insert the Square Timing Rod's ends into the square recesses on both Side Panels. Tighten the screw on the Square Timing Rod to lock the rod's length. See illustration #5.

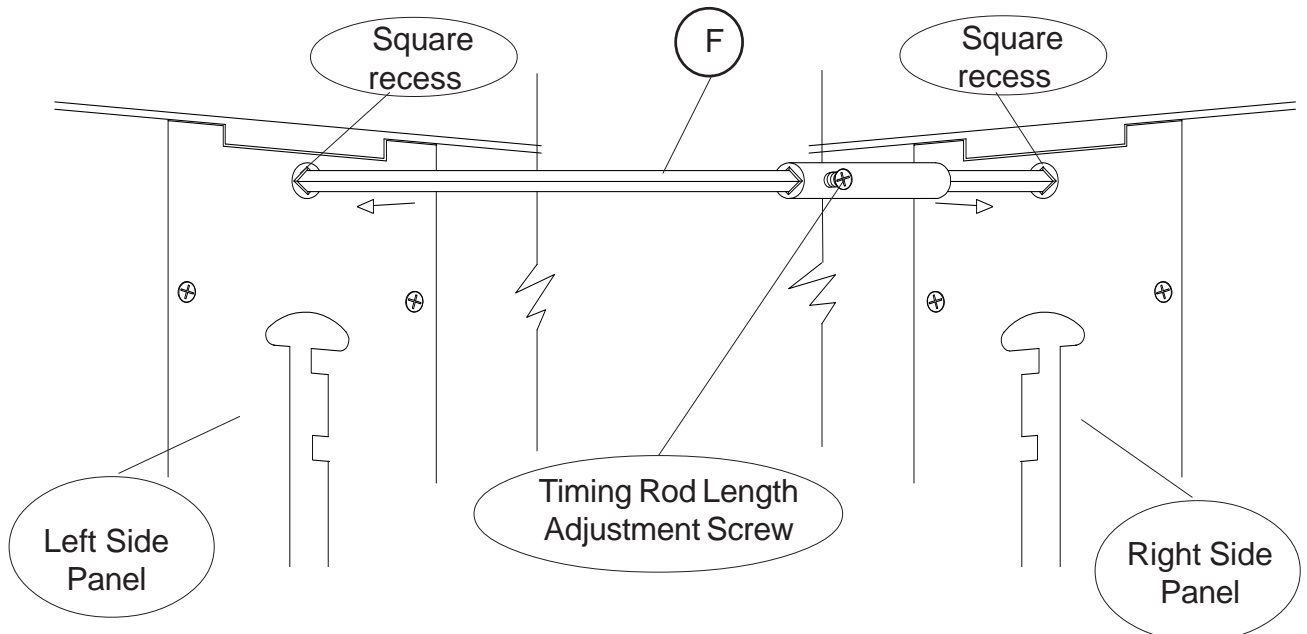
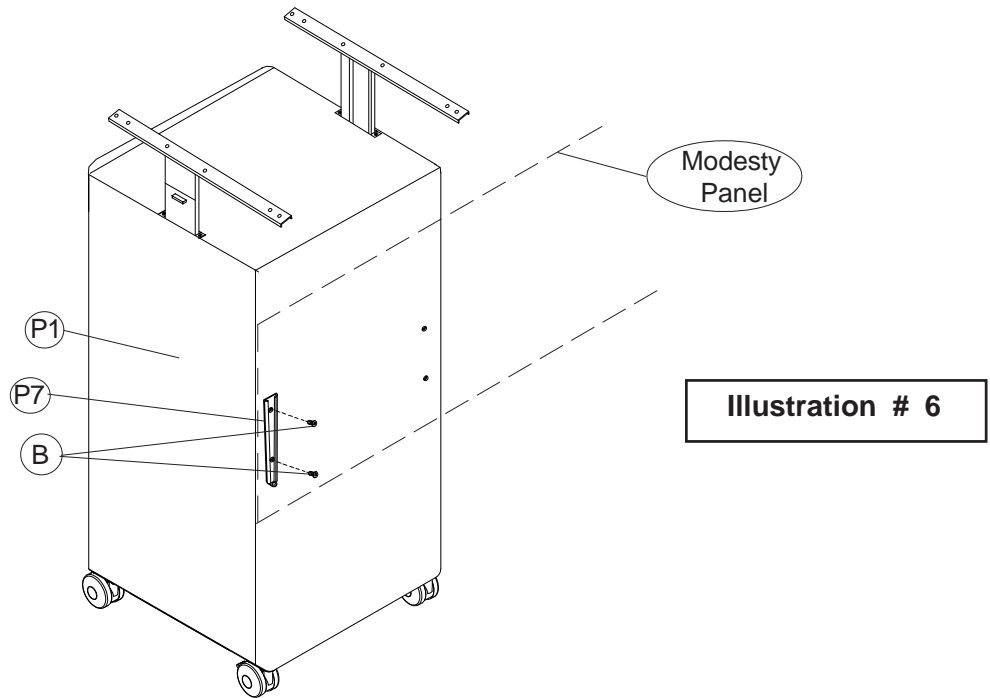

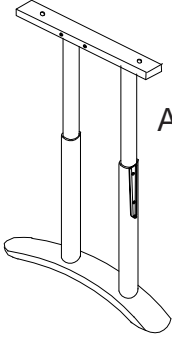
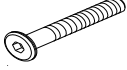





Illustration # 5

Inside View of Cabinet  
at Top

8.) Attach an Outer V Bracket (P7) to the back of the Pedestal Box (P1) using two Screws (B). Switch the Outer V Bracket to the other side of the Pedestal Box if the Modesty Panel will be opposite of the illustration #6.

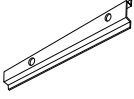

# Modular Teacher's Desk Leg-90390

Part	Drawing	Description	Qty	Part	Drawing	Description	Qty
P-1		Adjustable Leg-1S	1 EA	<div style="border: 2px solid black; padding: 10px;"> <p style="text-align: center;"><b>Hardware List</b></p> <p>A  Screw M6* 38mm 2 EA</p> <p>B  CS Screw 1/4 X 12mm 3 EA</p> <p>C  Allen Wrench 1 EA</p> <p>D  Caster Wrench 1 EA</p> <p>E  Non-Locking Caster 1 EA</p> <p>F  Locking Caster 1 EA</p> <p>G  Lock Washer 2 EA</p> </div>			
P-2		V Bracket - Inner	1 EA				

**READ THROUGH INSTRUCTIONS FROM BEGINNING TO END BEFORE STARTING TO ASSEMBLE UNIT.**





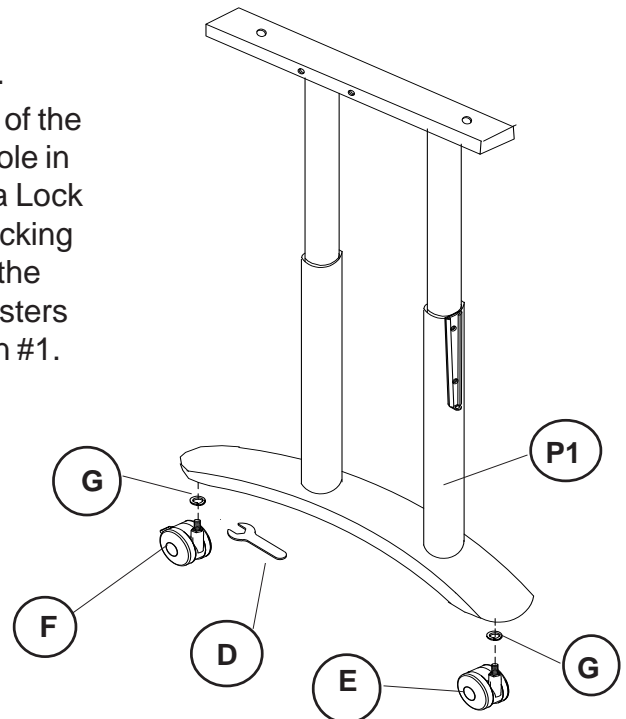





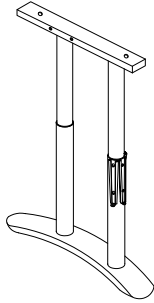
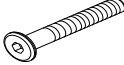





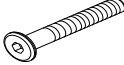

- 1.) Identify and Separate all the Parts and Hardware.
- 2.) Place a Lock Washer (G) on the threaded stem of the Locking Caster (F) and screw it into the front hole in the bottom of the Adjustable Leg (P1) . Place a Lock Washer (G) on the threaded stem of the Non-locking Caster (E) and screw it into the back hole in the bottom of the Adjustable Leg (P1). Tighten Casters with Caster Wrench (D) as shown in illustration #1.

Illustration # 1

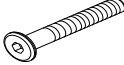

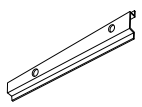

# Modular Teacher's Desk Leg-90391

Part	Drawing	Description	Qty	Part	Drawing	Description	Qty																												
P-1		Adjustable Leg-3S	1 EA	<div style="border: 2px solid black; border-radius: 15px; padding: 10px;"> <p style="text-align: center;">Hardware List</p> <table border="0"> <tr> <td>A</td> <td></td> <td>Screw M6*38mm</td> <td>2 EA</td> </tr> <tr> <td>B</td> <td></td> <td>CS Screw 1/4 X 12mm</td> <td>6 EA</td> </tr> <tr> <td>C</td> <td></td> <td>Allen Wrench</td> <td>1 EA</td> </tr> <tr> <td>D</td> <td></td> <td>Caster Wrench</td> <td>1 EA</td> </tr> <tr> <td>E</td> <td></td> <td>Non-Locking Caster</td> <td>1 EA</td> </tr> <tr> <td>F</td> <td></td> <td>Locking Caster</td> <td>1 EA</td> </tr> <tr> <td>G</td> <td></td> <td>Lock Washer</td> <td>2 EA</td> </tr> </table> </div>				A		Screw M6*38mm	2 EA	B		CS Screw 1/4 X 12mm	6 EA	C		Allen Wrench	1 EA	D		Caster Wrench	1 EA	E		Non-Locking Caster	1 EA	F		Locking Caster	1 EA	G		Lock Washer	2 EA
A		Screw M6*38mm	2 EA																																
B		CS Screw 1/4 X 12mm	6 EA																																
C		Allen Wrench	1 EA																																
D		Caster Wrench	1 EA																																
E		Non-Locking Caster	1 EA																																
F		Locking Caster	1 EA																																
G		Lock Washer	2 EA																																
P-2		V Bracket - Inner	2 EA																																

**READ THROUGH INSTRUCTIONS FROM BEGINNING TO END BEFORE STARTING TO ASSEMBLE UNIT.**

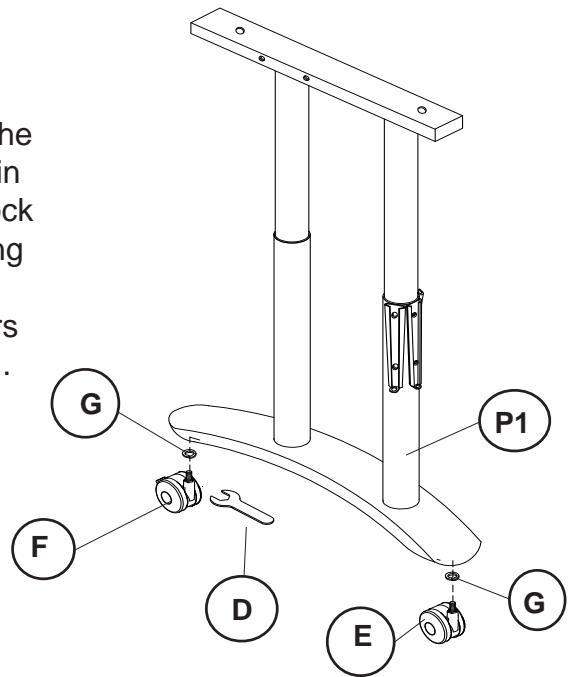

- 1.) Identify and Separate all the Parts and Hardware.
- 2.) Place a Lock Washer (G) on the threaded stem of the Locking Caster (F) and screw it into the front hole in the bottom of the Adjustable Leg (P1) . Place a Lock Washer (G) on the threaded stem of the Non-locking Caster (E) and screw it into the back hole in the bottom of the Adjustable Leg (P1). Tighten Casters with Caster Wrench (D) as shown in illustration #1.

Illustration # 1

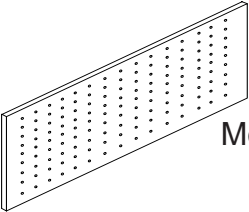

# Modular Teacher's Desk Modesty Panel

## 58258-60", 58259-72"

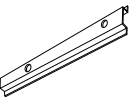
Part	Drawing	Description	Qty	Part	Drawing	Description	Qty	
P-1		Modesty Panel	1 EA	<b>Hardware List</b>				
				A		CS Screw 1/4X12mm	6 EA	
						This part is in the Leg / Pedestal Packages		
				B		Allen Wrench	1 EA	
						This part is in the Leg / Pedestal Packages		
P-2		V Bracket - Inner	2 EA					
		This part is in the Leg / Pedestal Packages						

**READ THROUGH INSTRUCTIONS FROM BEGINNING TO END BEFORE STARTING TO ASSEMBLE UNIT.**

- 1.) Identify and Separate all the Parts and Hardware.
- 2.) Place a V Bracket - Inner (P2) on the back of the left side of the Modesty Panel (P1) over the tapped holes at your chosen height setting. Attach the V Bracket using two CS Screws (A). Repeat this Step to install the right side V Bracket as shown in illustration #1. Tighten screws with Allen Wrench (B).

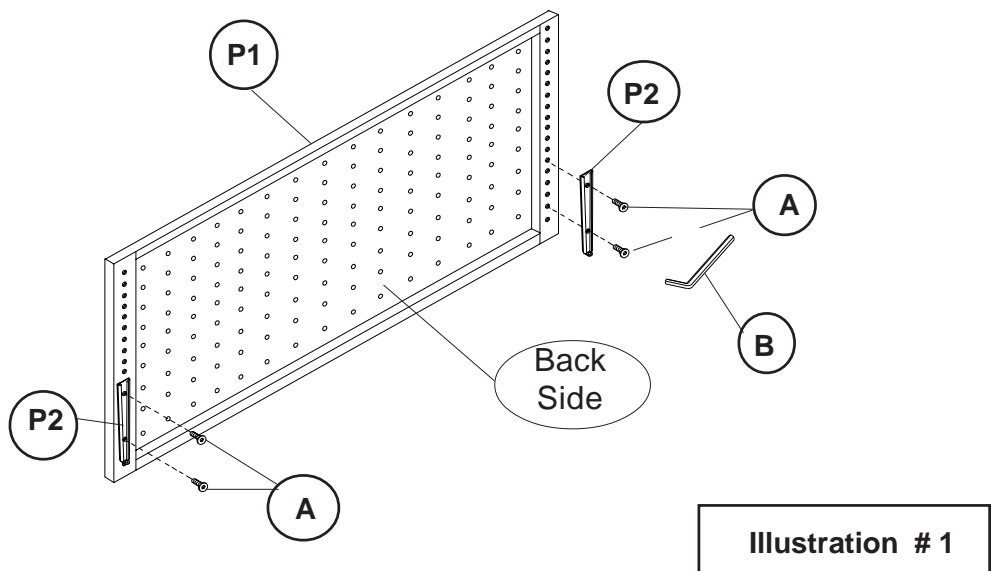

## When Building Single Desk

- 3.a) Make sure your Leg and Modesty Panel heights are set. Slide the Modesty Panel's (58258 or 58259) V Brackets into the the V Brackets on the two Adjustable Leg-1S (90390) as shown in illustration #2a. Lock the Modesty Panel to the Legs using one Screw (B) through the bottom of the V Brackets. Tighten with Allen Wrench (C).

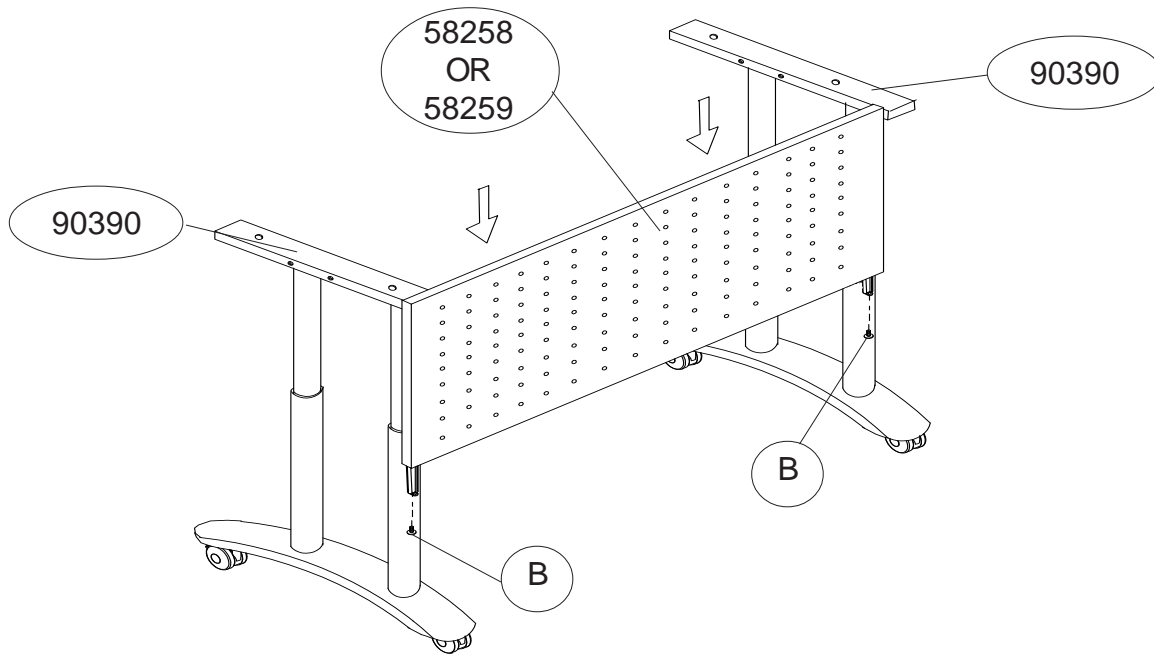

## When Building L Desks

- 3.b) Make sure your Leg and Modesty Panel heights are set. Slide the Modesty Panel's (58258 or 58259) V Brackets into the the V Brackets on the Adjustable Leg-1S (90390) and the Adjustable Leg-3S (90391) as shown in illustration #2b. Lock the Modesty Panel to the Legs using one Screw (B) through the bottom of the V Brackets. Tighten with Allen Wrench (C).

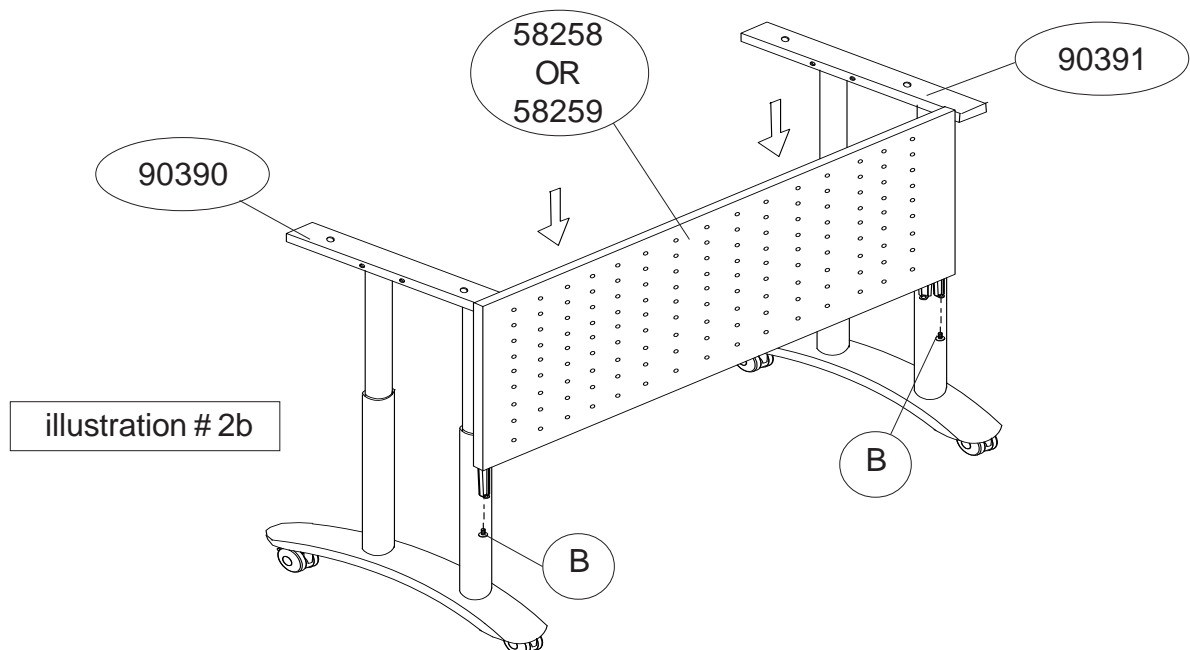

## When Building Single Desk

- 3.c) Make sure your Leg, Pedestal and Modesty Panel heights are set. Slide the Modesty Panel's (58258 or 58259) V Brackets into the the V Brackets on the Adjustable Leg-1S (90390) and Modular Pedestal (90369) as shown in illustration #2c. Lock the Modesty Panel to the Leg and Pedestal using one Screw (B) through the bottom of each V Bracket. Tighten with Allen Wrench (C).

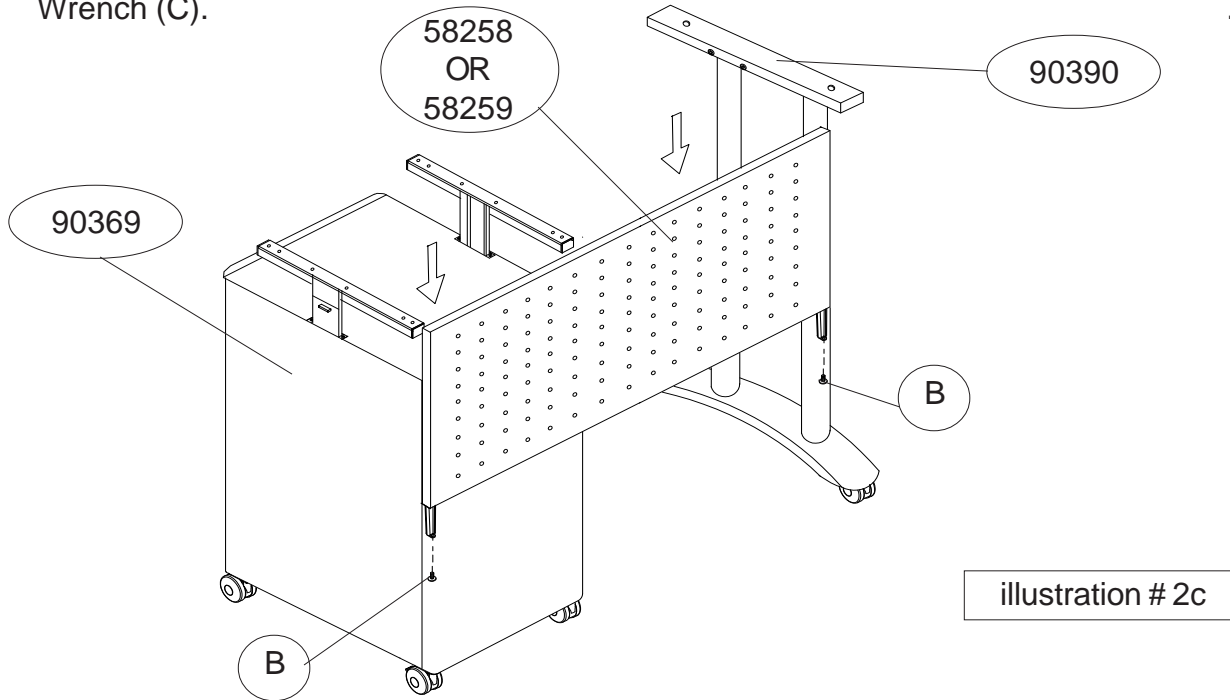

## When Building L Desks

- 3.d) Make sure your Leg, Pedestal and Modesty Panel heights are set. Slide the Modesty Panel's (58258 or 58259) V Brackets into the the V Brackets on the Adjustable Leg-3S (90391) and the Modular Pedestal (90369) as shown in illustration #2d. Lock the Modesty Panel to the Leg and Pedestal using one Screw (B) through the bottom of the V Brackets. Tighten with Allen Wrench (C).

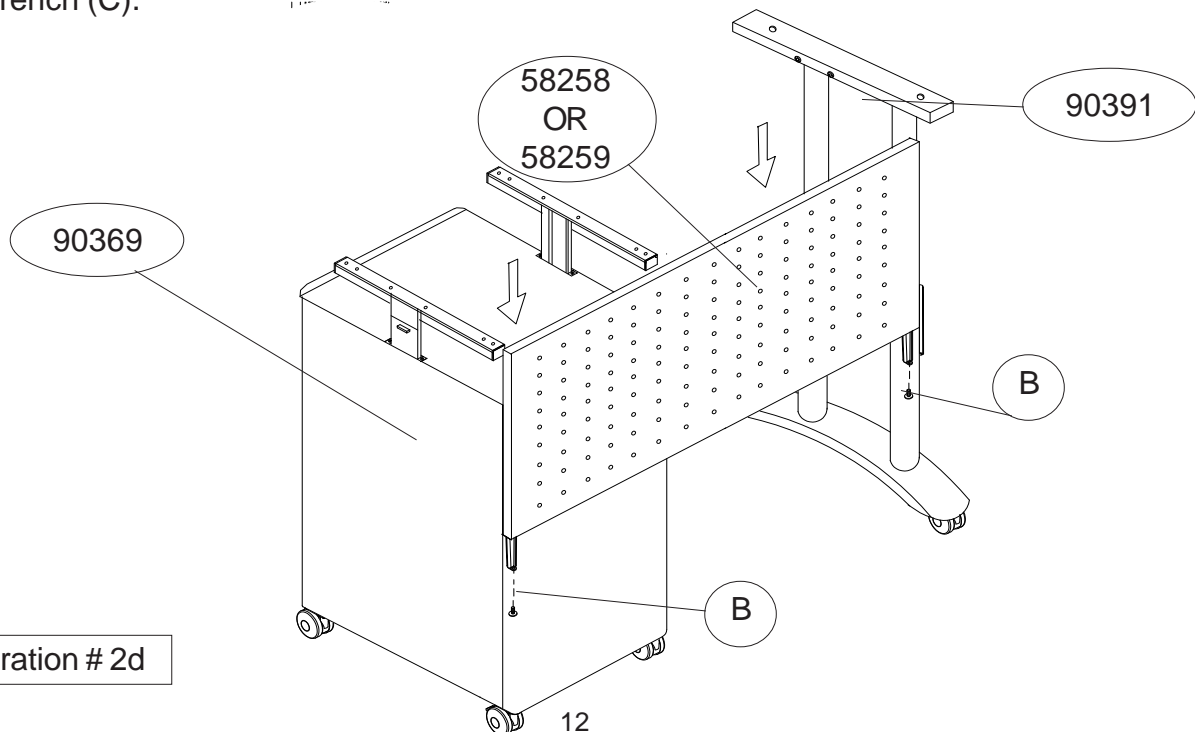

# When Building Single Desk

3.e) Make sure your Pedestals and Modesty Panel heights are set. Slide the Modesty Panel's (58258 or 58259) V Brackets into the the V Brackets on the two Modular Pedestals (90369) as shown in illustration #2e. Lock the Modesty Panel to the Pedestals using one Screw (B) through the bottom of each V Bracket. Tighten with Allen Wrench (C).

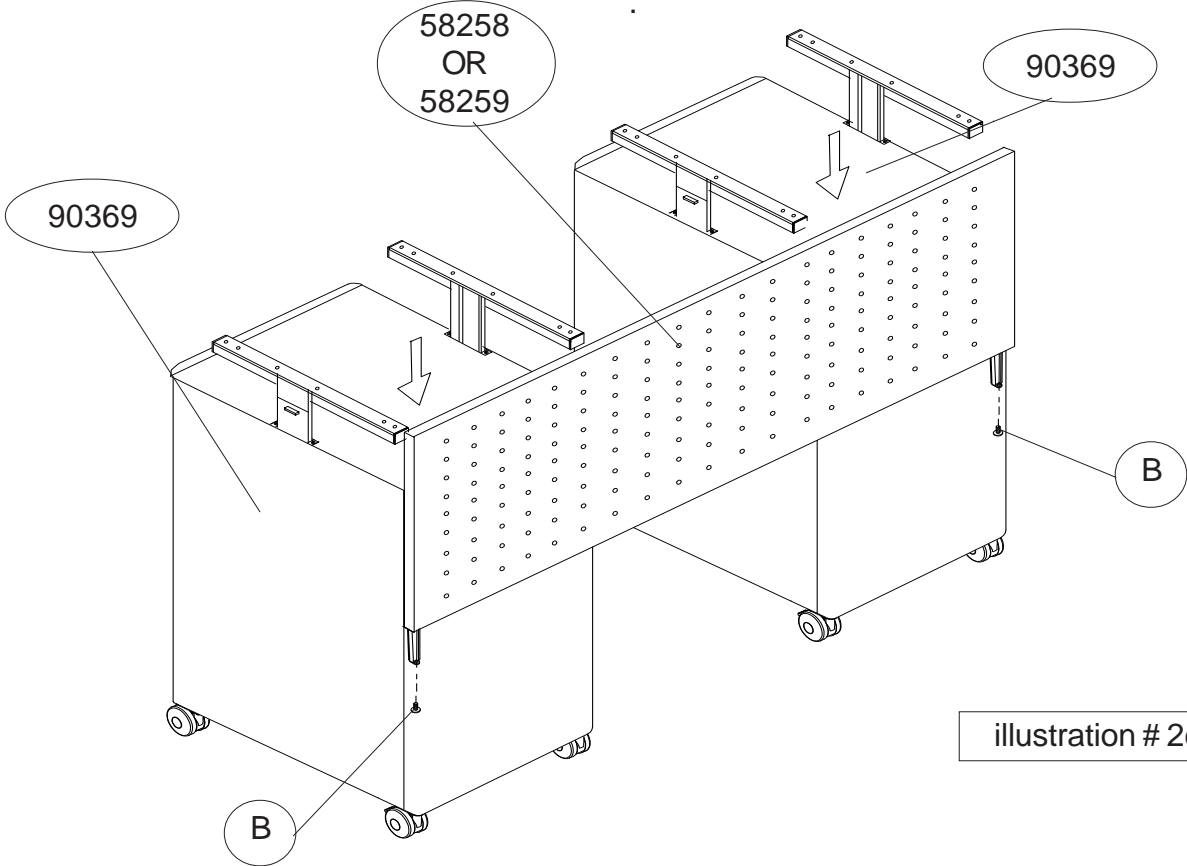
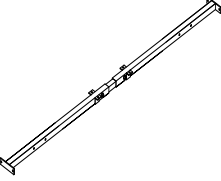
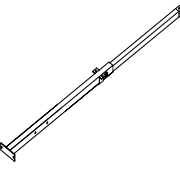



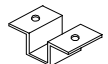

illustration # 2e

# Modular Teacher's Desk Adjustable Support Bar 58261, XXXXX

Part	Drawing	Description	Qty
58261		Adjustable Support Tube	
XXXXX		Pedestal Support Tube	

Part	Drawing	Description	Qty
<b>Hardware List</b>			
A		Screw 1/4 X 38 mm	
B		CS Screw 1/4 X 9MM	
C		Allen Wrench	
D		Set Screw	
E		U Clamp	

**READ THROUGH INSTRUCTIONS FROM BEGINNING TO END BEFORE STARTING TO ASSEMBLE UNIT.**

1.) Identify and Separate all the Parts and Hardware.

Install the Set Screws (D) into the Adjustable Support Tube (58261) T-nut inserts. Attach this loose assembly between the two Adjustable Legs and secure using four Screws (A) as shown in illustration #1a.

## OR

Install the Set Screw (D) into the Pedestal Support Tube (XXXXX) T-nut insert. Attach this loose assembly between the Adjustable Leg and Modular Pedestal and secure using two Screws (A) as shown in illustration #1b.

**NOTE: The Modesty Panel must be installed before the Top is attached.**

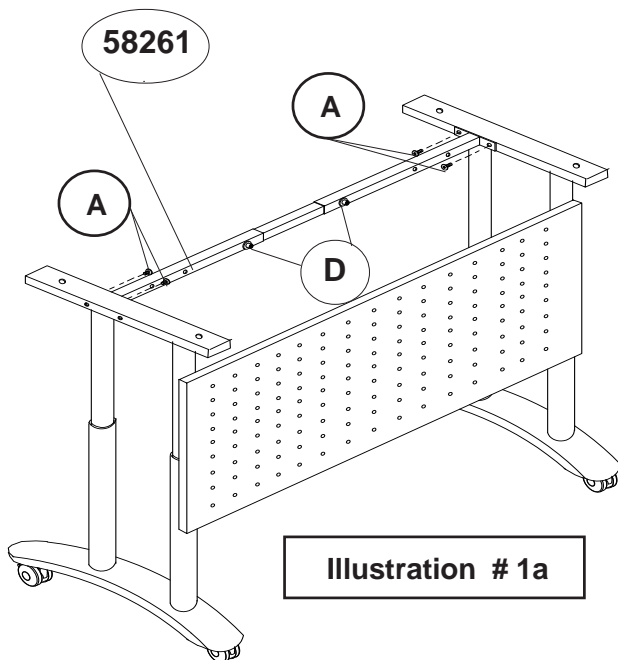

## OR

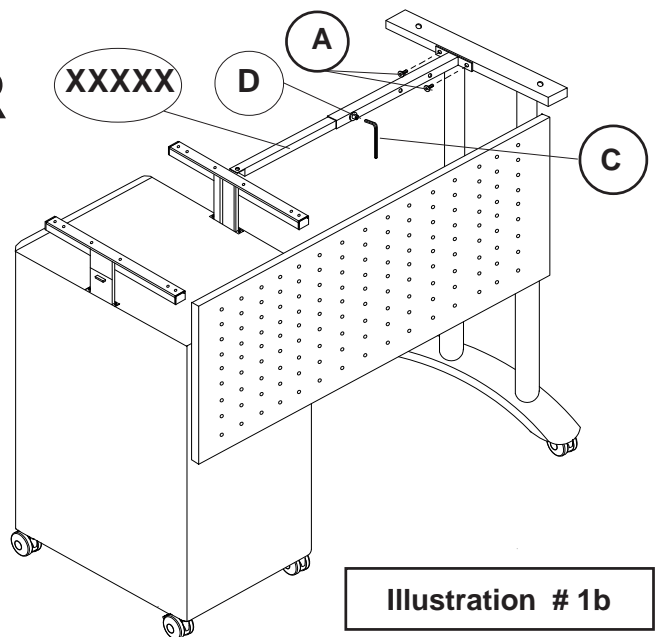

3a.) Attach Adjustable Leg (90390) to the second Adjustable Support Bar (58261) using two Screws (A) as shown in illustration #2a. Attach the other end of the Adjustable Support Bar to the first Adjustable Support Bar using two more Screws (A). Leave the two Set Screws in the Adjustable Support Bar loose until second Modesty Panel is installed.

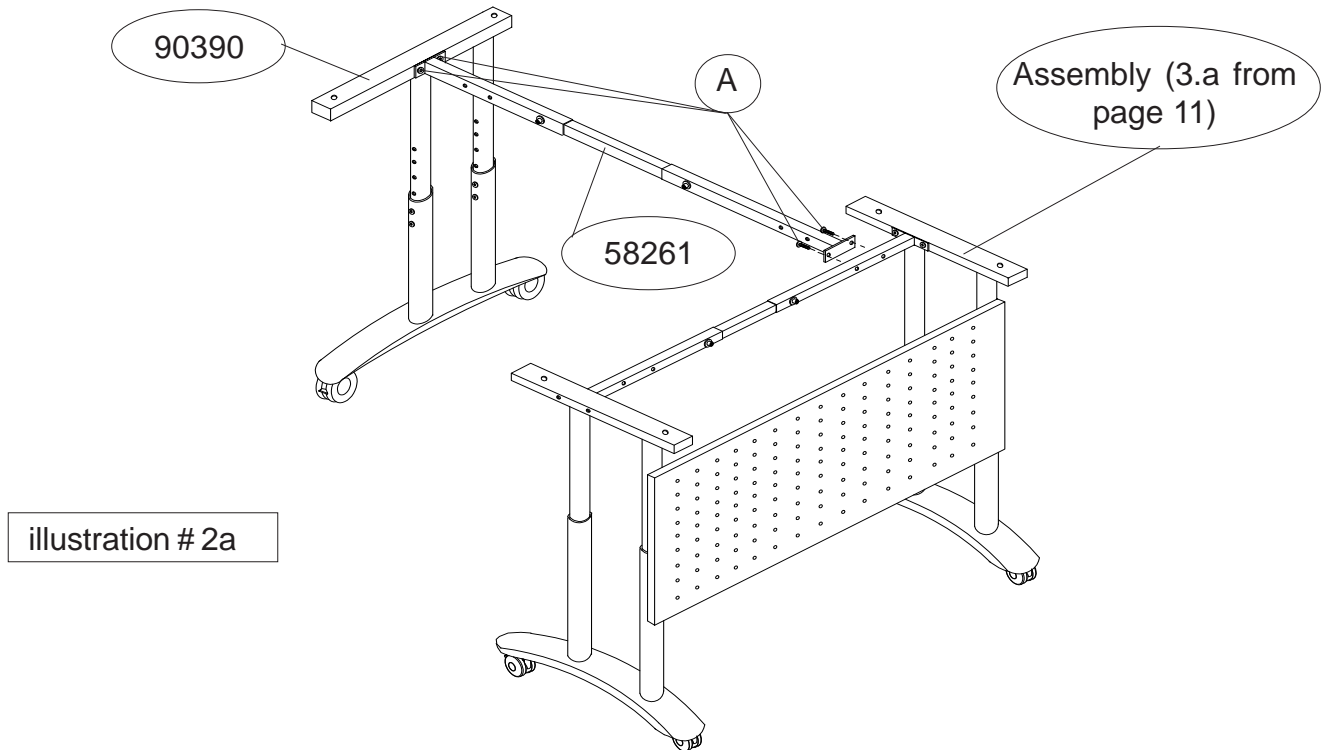

4a.) Insert the V Brackets on the second Modesty Panel (58259) into the V Brackets on the Legs as shown in illustration #3a. Lock the Modesty Panel to the Legs using one Screw (B) through the bottom of the V Brackets (see Step 3 on page 9) Tighten with Allen Wrench (C).

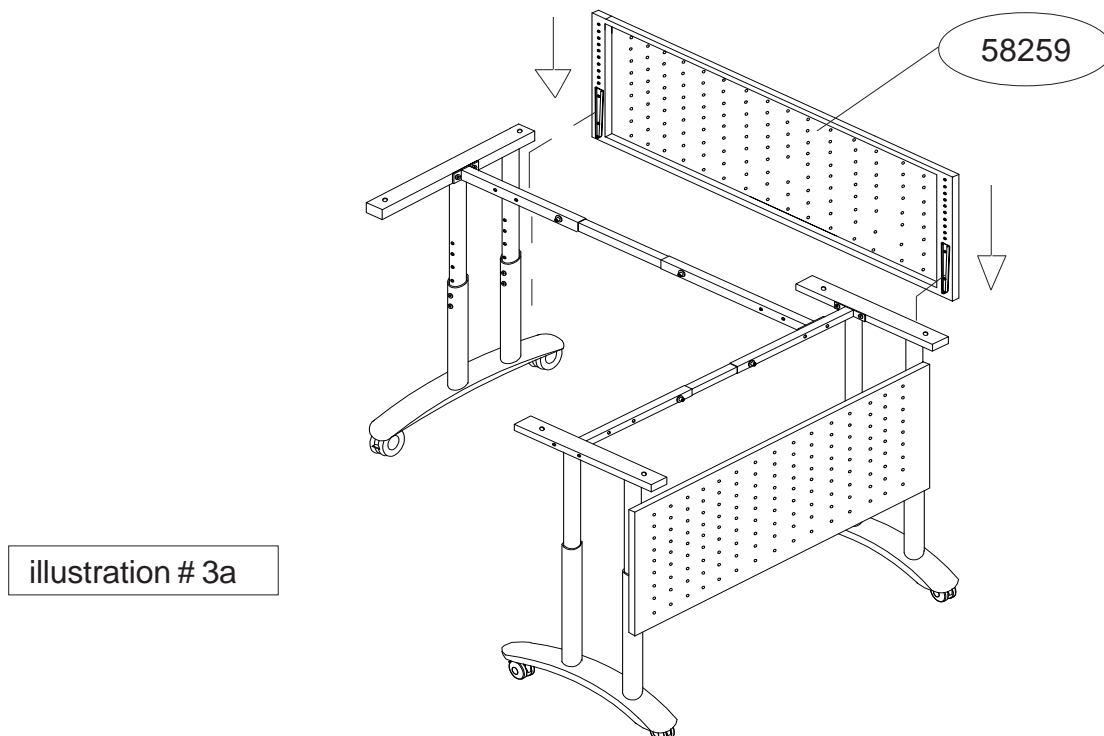

3b.) Attach Adjustable Leg (90390) to the second Adjustable Support Bar (58261) using two Screws (A) as shown in illustration #2b. Attach the other end of the Adjustable Support Bar to the first Adjustable Support Bar using two more Screws (A). Leave the two Set Screws in the Adjustable Support Bar loose until second Modesty Panel and the Top are installed.

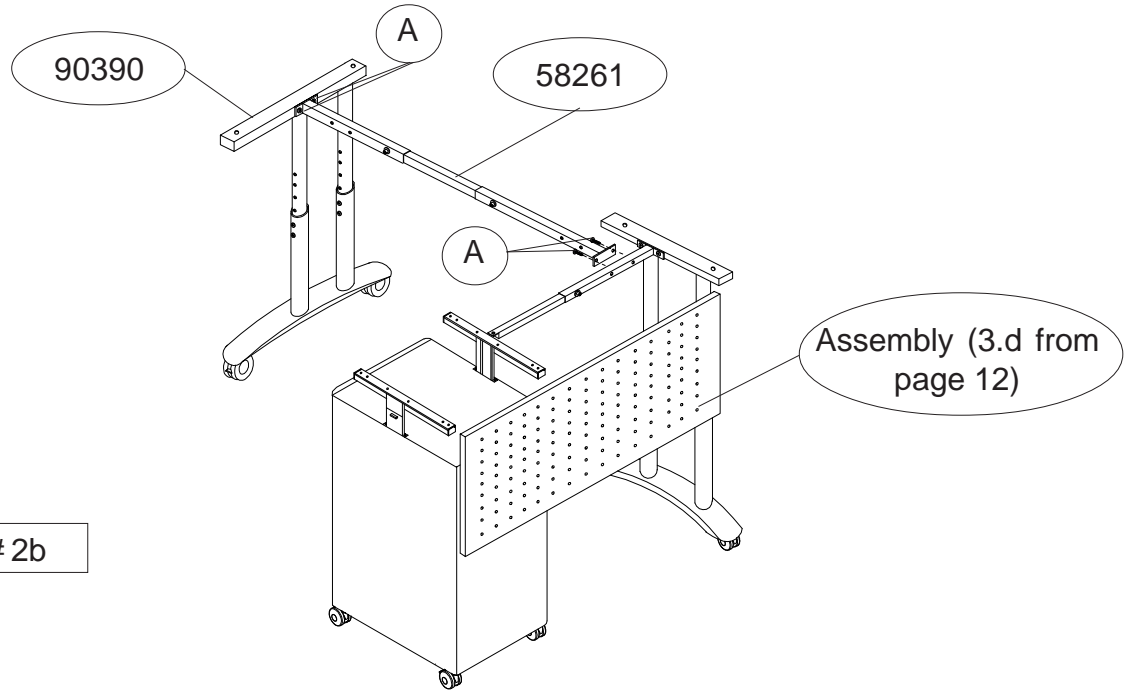

4b.) Insert the V Brackets on the second Modesty Panel (58259) into the V Brackets on the Legs as shown in illustration #3b. Lock the Modesty Panel to the Legs using one Screw (B) through the bottom of the V Brackets (see Step 3 on page 9) Tighten with Allen Wrench (C).

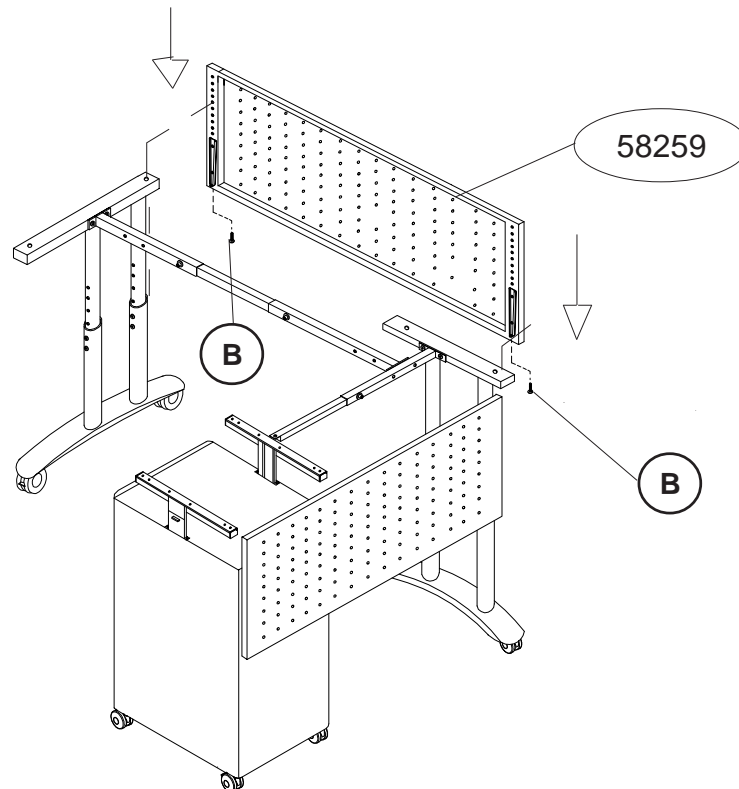



1.) Line up the holes in the bottom of the two Tops with the holes in the Adjustable Leg's top support and attach using six Screws (A).

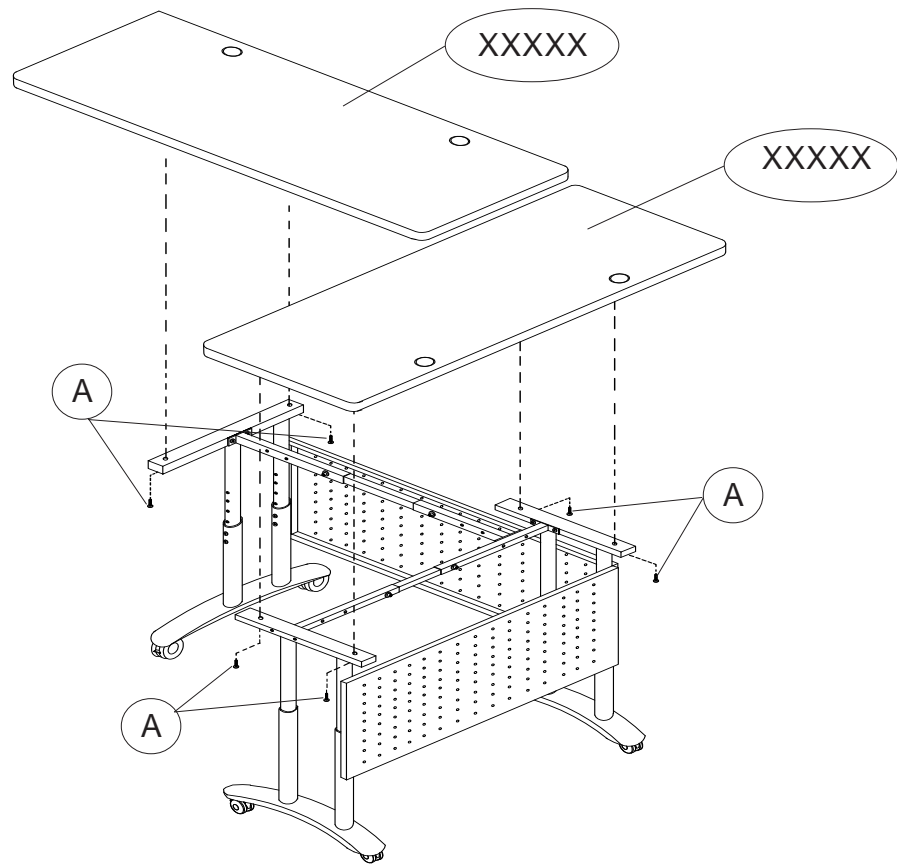

illustration # 1

2.) Place four U Clamps (P-2) over the Adjustable Support Bars (P-1) and attach to Tops using eight Screws (B) as shown in illustration #2. Place two Gangers over the touching Tops edges and secure in place using four Screws (A).

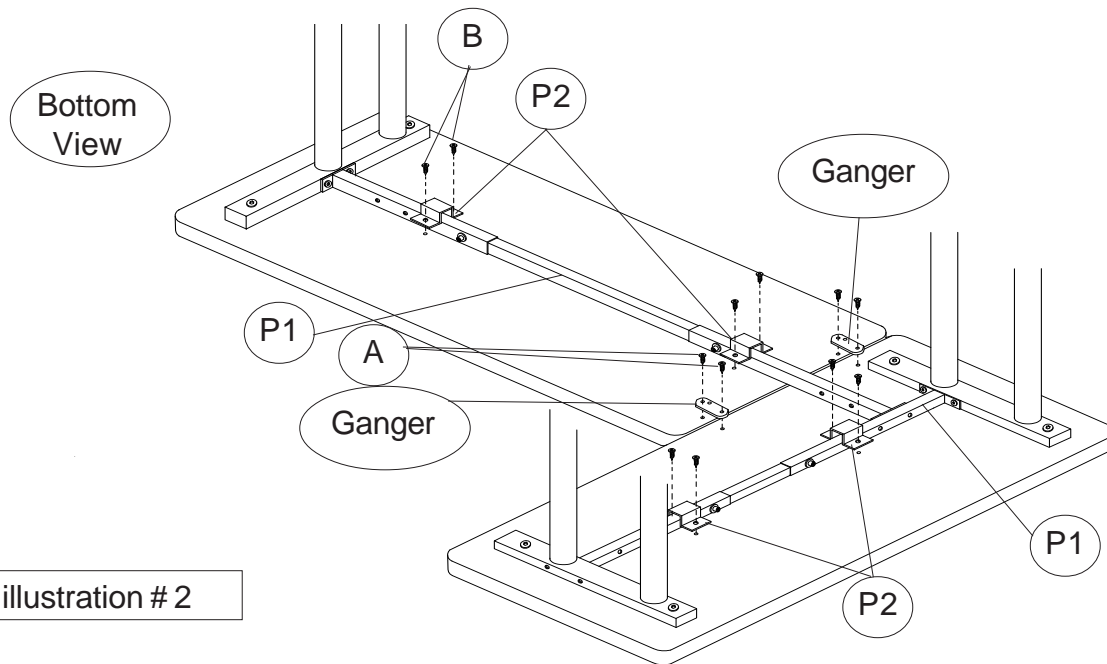
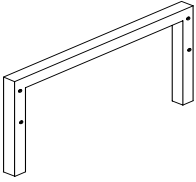



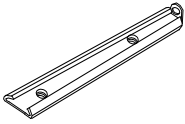
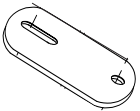

illustration # 2

# Modular Teacher's Desk Leg Support -58260



Part	Drawing	Description	Qty	Part	Drawing	Description	Qty
P1		U Support Tube	1 EA	<p style="text-align: center;"><b>Hardware List</b></p> <p>A  CS 1/4X12mm 4 EA</p> <p>B  Allen Wrench 1 EA</p> <p>C  Screw M6*18mm 4 EA</p>			
P2		V Bracket-Inner	2 EA				
P3		Ganger	2 EA				

**READ THROUGH INSTRUCTIONS FROM BEGINNING TO END BEFORE STARTING TO ASSEMBLE UNIT.**

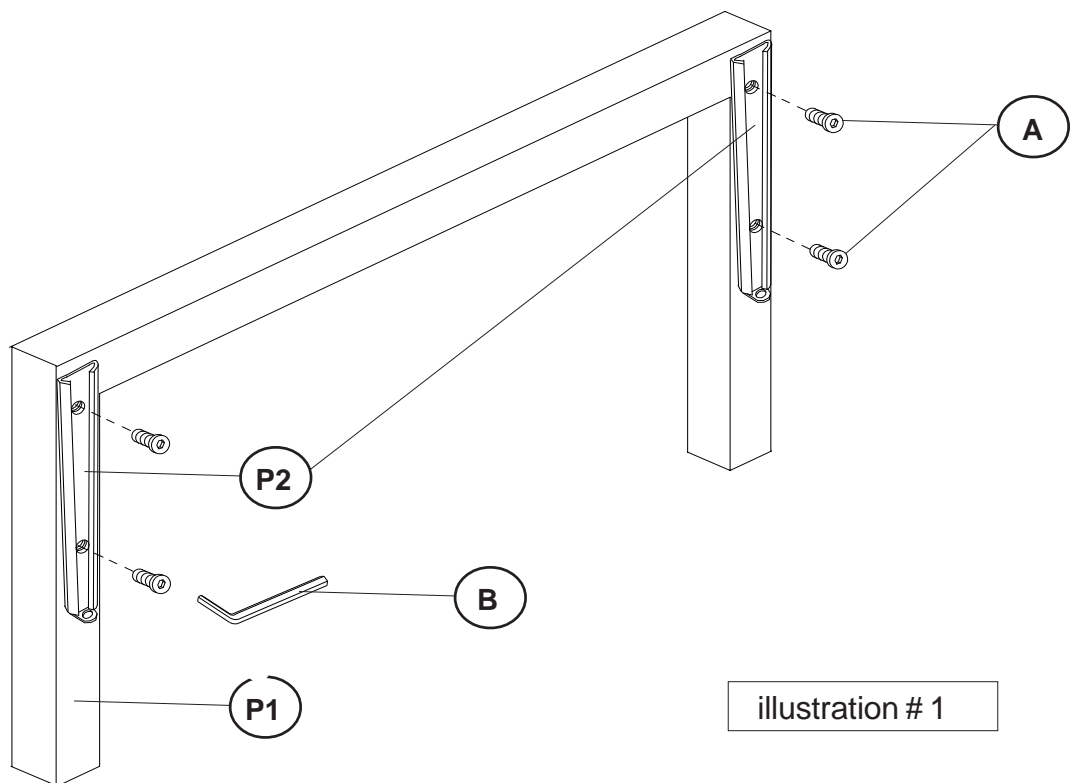
- 1.) Identify and Separate all the Parts and Hardware.
- 2.) Connect the two V Brackets-Inner to the U Support Tube (P1) using two CS Screws (A). Tighten screws with Allen Wrench (B) as shown in illustration # 1.

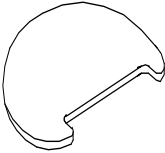
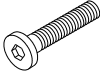

# Modular Teacher's Desk Round End

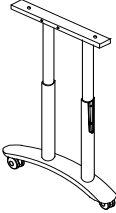
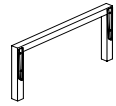
Part	Drawing	Description	Qty	Part	Drawing	Description	Qty
XXXXX		Top	1 EA	<div style="border: 2px solid black; border-radius: 15px; padding: 10px;"> <p style="text-align: center;">Hardware List</p> <p>A  Screw M6* 38mm 4 EA</p> <p>B  Allen Wrench 1 EA</p> <p>C  CS 1/4X12mm 2 EA</p> </div>			
90390		Adjustable Leg	2 EA				
58260		Leg Support	1 EA				

## Modular Teacher's Desk Round End Assembly Instruction

**READ THROUGH INSTRUCTIONS FROM BEGINNING TO END BEFORE STARTING TO ASSEMBLE UNIT.**

- 1.) Identify and Separate all the Parts and Hardware.
- 2.) Connect the two assembled Adjustable Legs(90390) together using the Leg Support (58260) as shown in illustration # 1. Align the V Brackets on each part and slip the parts together.

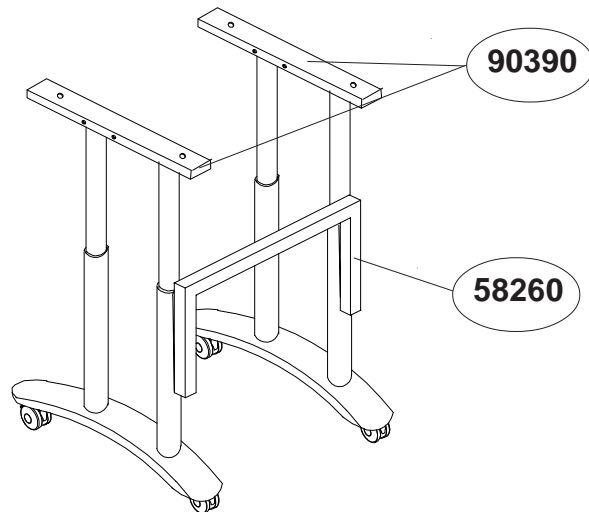

illustration # 1

4.) Lock the assembly from Step 3 together using a CS Screw (C) in the bottom of each V bracket as shown in illustration #2

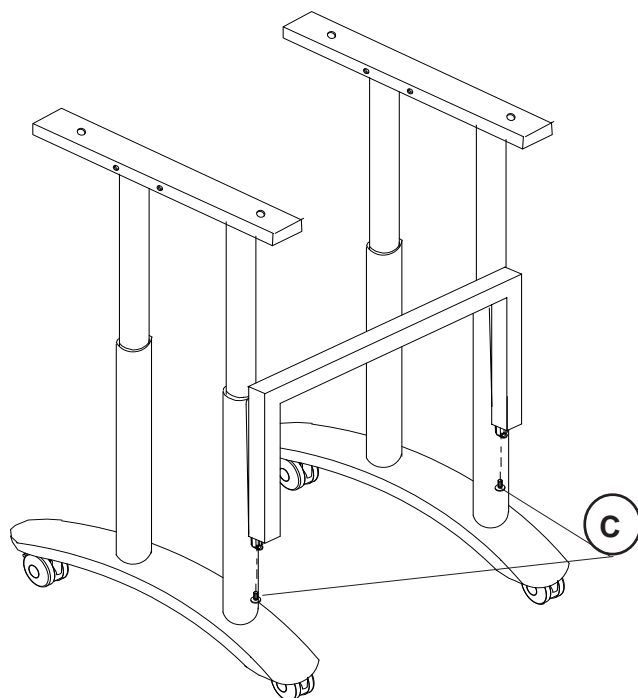

illustration # 2.

5.) Attach the Top (XXXXX) to the assembly from Step 4 using four Screws (A) as shown in illustration #3.

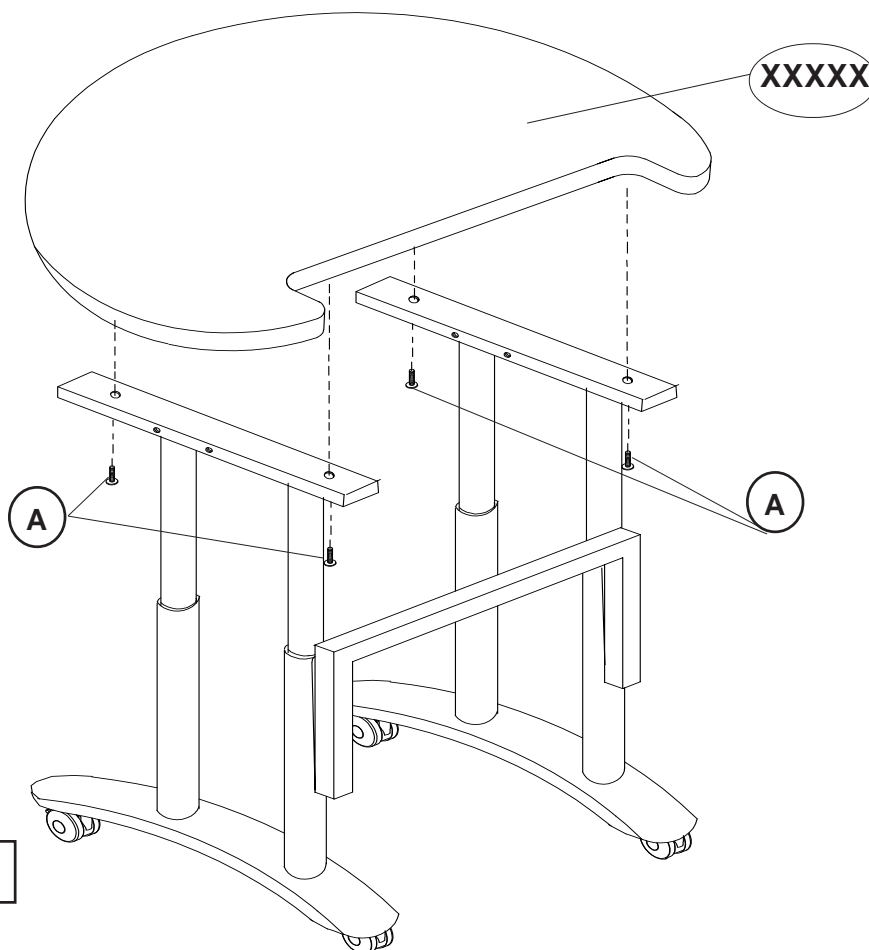





Illustration # 3

# Modular Teacher's Desk Top Ganger

Part	Drawing	Description	Qty	Part	Drawing	Description	Qty
P-1		Ganger	2 EA	Hardware List			
A		Screw M6*18 mm	4 EA	B		Allen Wrench	1 EA

1.) Place two Gangers(P1) over the touching Top's edges and secure in place using four Screws (A) into the embedded threaded inserts under the edges. Tighten Screws with Allen Wrench (B). See illustration #1 below.

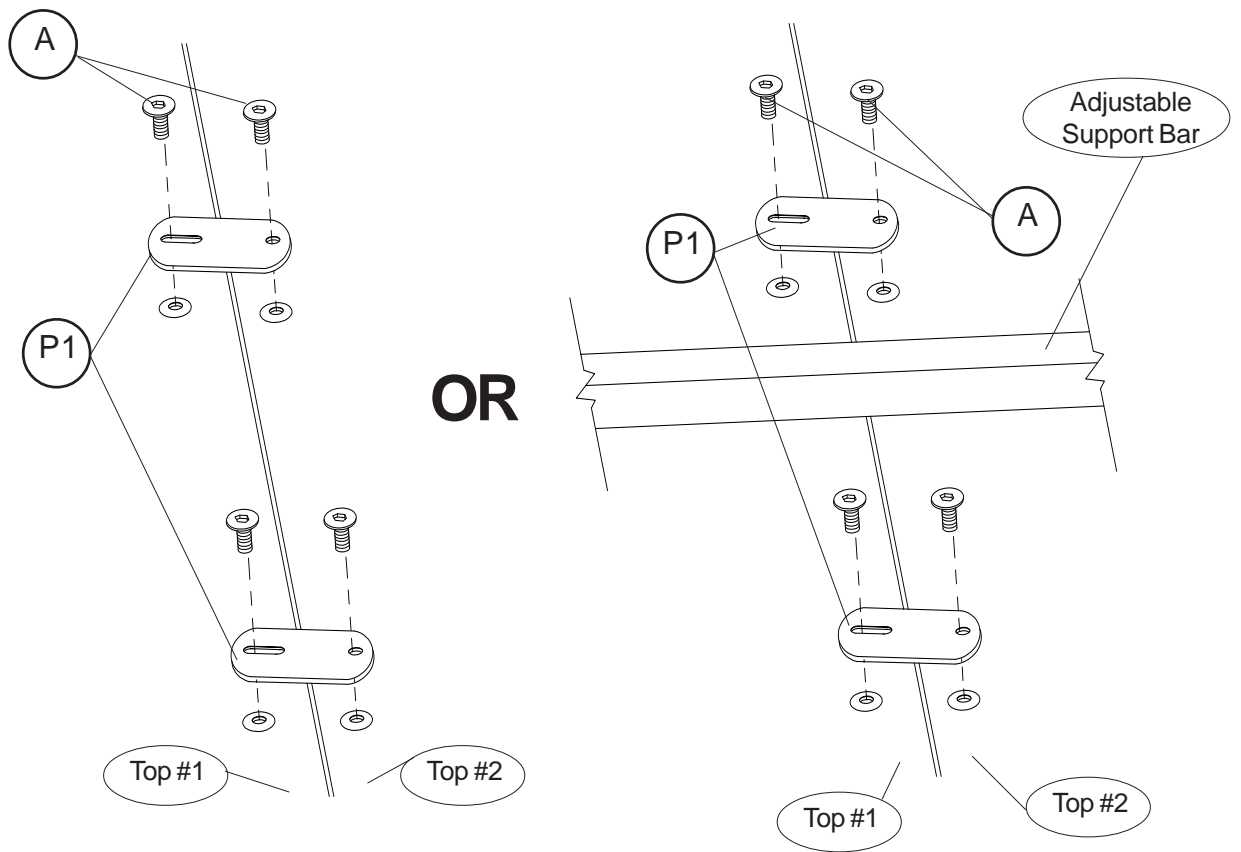

illustration # 1