

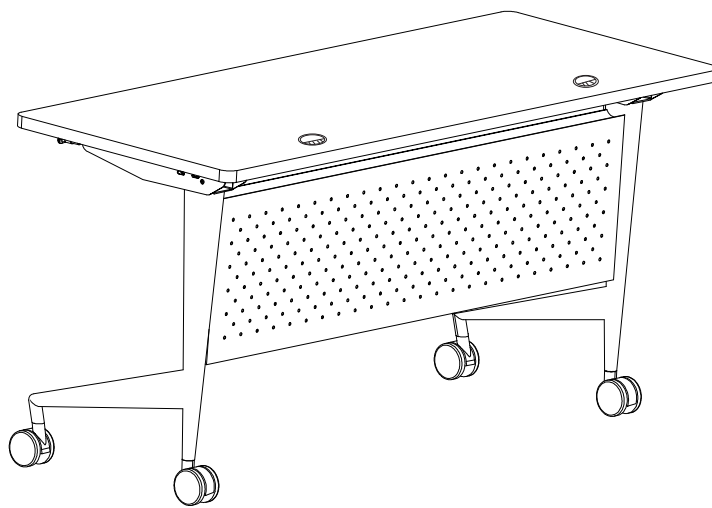

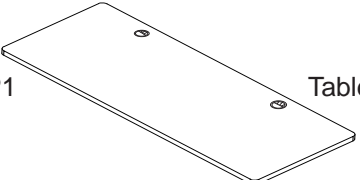





Trend Table

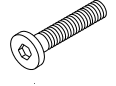

Assembly Instructions

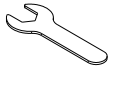
Trend Table

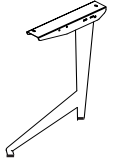
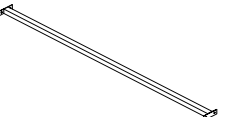
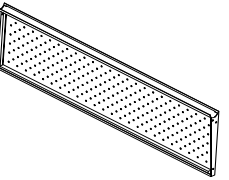
Part	Drawing	Description	Qty	Part	Drawing	Description	Qty
P1		Table Top	1 EA	Hardware List A  M6*20mm Screw 4 EA A1  1/4 X 12mm Screw 10 EA A2  M6*38mm Screw 2 EA B  Locking Caster 2 EA C  Non-Locking Caster 2 EA D  Allen Wrench 1 EA E  Caster Wrench 1 EA F  Lock Washer 4 EA			
P2		Rightt Leg	1 EA				
P3		Left Leg	1 EA				
P4		Top Support	1 EA				
P5		Modesty Panel	1 EA				

Trend Table

Assembly Instructions

READ THROUGH INSTRUCTIONS FROM BEGINNING TO END BEFORE STARTING TO ASSEMBLE UNIT.

- 1.) Identify and Separate all the Parts and Hardware.
- 2.) Attach the Top Support (P4) to Left Leg (P3) using two Screws (A1). Attach the other end of the Top Support (P4) to the Right Leg (P2) using two Screws (A1). Tighten the Screws (A1) using Allen Wrench (D) as shown in Illustration #1.

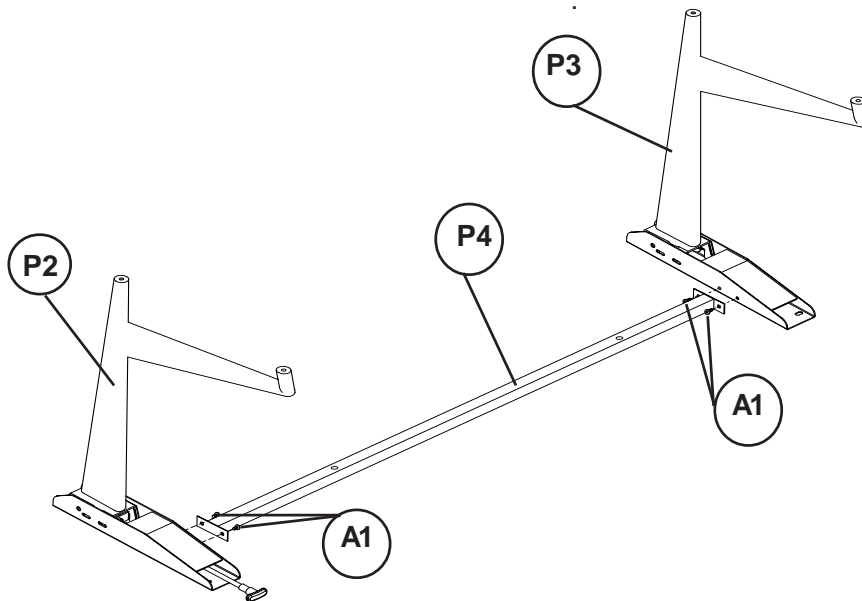

Illustration # 1

- 3.) Place the Table Top (P1) face down on a padded surface. Take the assembly from Step #2 and center it over the embedded threaded inserts in the bottom of the Table Top (P1). Use two Screws (A) to attach each Leg's top bracket to the Table Top (p1) as shown in Illustration #2. Use two Screws (A2) to secure the Top Support (P4) to the bottom of the Table Top (P1).

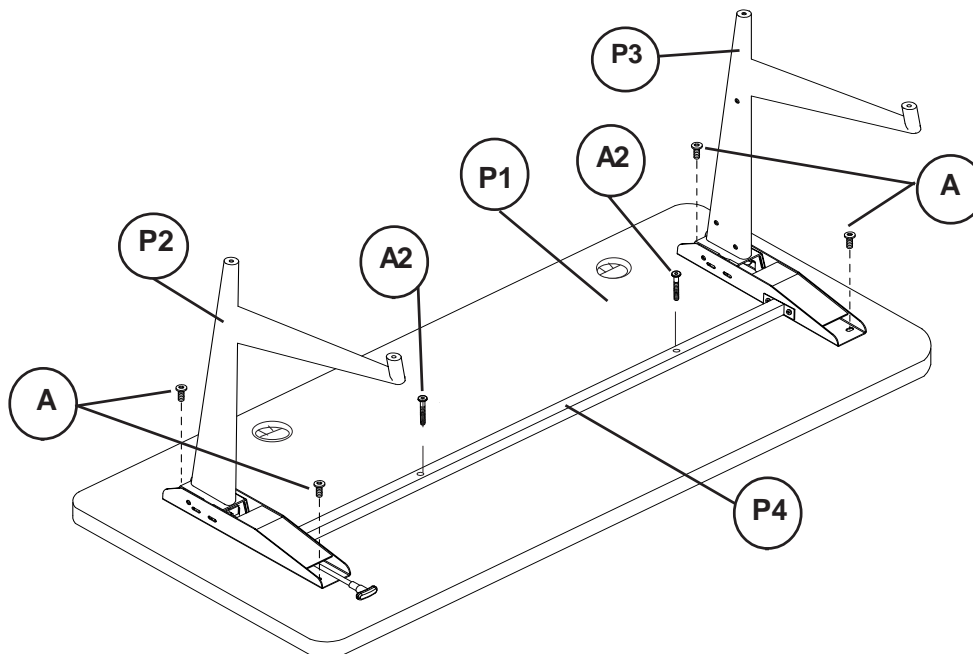

Illustration # 2

- 4.) Position the Modesty Panel (P5) between the Right Leg (P2) and the Left Leg (P3) as shown in Illustration #3. Attach the Modesty Panel (P5) using three Screws (A1) for each leg. Tighten with Allen Wrench (D).

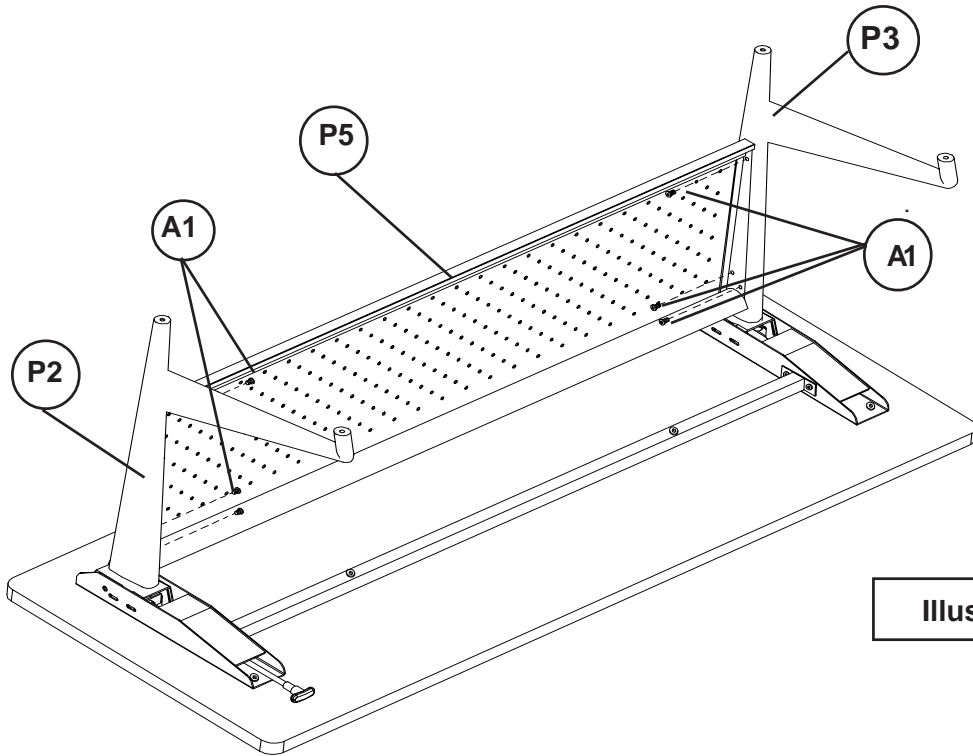

Illustration # 3

- 5.) Place a Lock Washer (F) on the threaded stem of each caster. Screw in two Locking Casters (B) into the front legs and two Non-Locking casters (C) into the rear legs and tighten all using Caster Wrench (E)

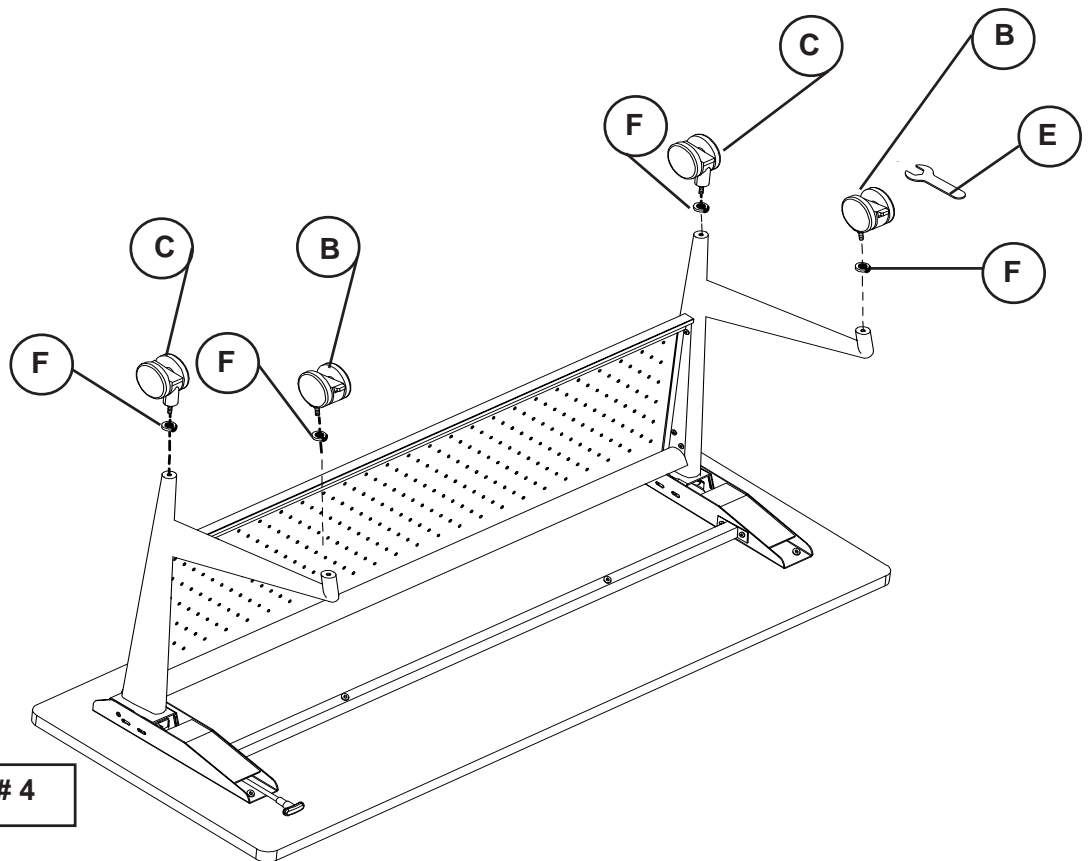

Illustration # 4

Trend Table

