

Mobile Floor Display Panel

Model No: 689D-XX

PANEL:

Panel is 48" x 66" x 7/16" Hexacomb double sided in either hook-and-loop fabric or vinyl surface. Surface is fully tackable.

FRAME:

Frame consists of four 18 gauge steel trim pieces. Each piece is constructed from 22.5mm square tube with a U-channel welded to inside edge. A single M6 x 40mm SH screw with washer inserts from outside of side trim pieces and threads into metal insert within tubing on top and bottom trim pieces in each corner of panel. U-channel holds panel in place. Side trim pieces insert into feet and are locked in place with one M6x15mm screw per foot. Feet are constructed of two welded pieces of 18 gauge, 25mm square tubing with threaded inserts welded on bottom to receive casters. All exposed tubing ends are capped with plastic inserts.

CASTERS:

Casters are 50mm, dual wheel with M10 x 14mm threaded stem. Two locking and two non-locking casters provided.

GANGING:

Panels may be linked together in series or set up radially using set of gangers. Included with each mobile panel is one pair each of straight, 90 degree, and 120 degree gangers. To link panels, feet are left off and replaced with plastic inserts. Two gangers are used along one side of linked edge and attach to each display panel's side trim with one M6 x 40mm screw that is capped on one end with a locknut.

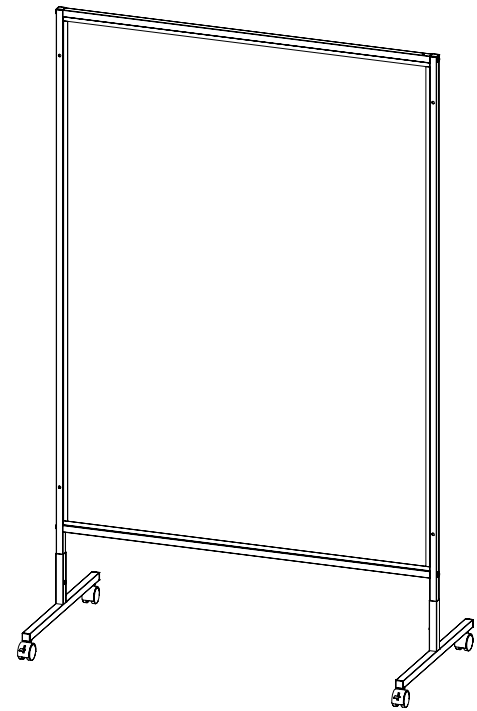

COMPLIANCE:

SCS Indoor Advantage Gold certified.

Meets or exceeds BIFMA testing.

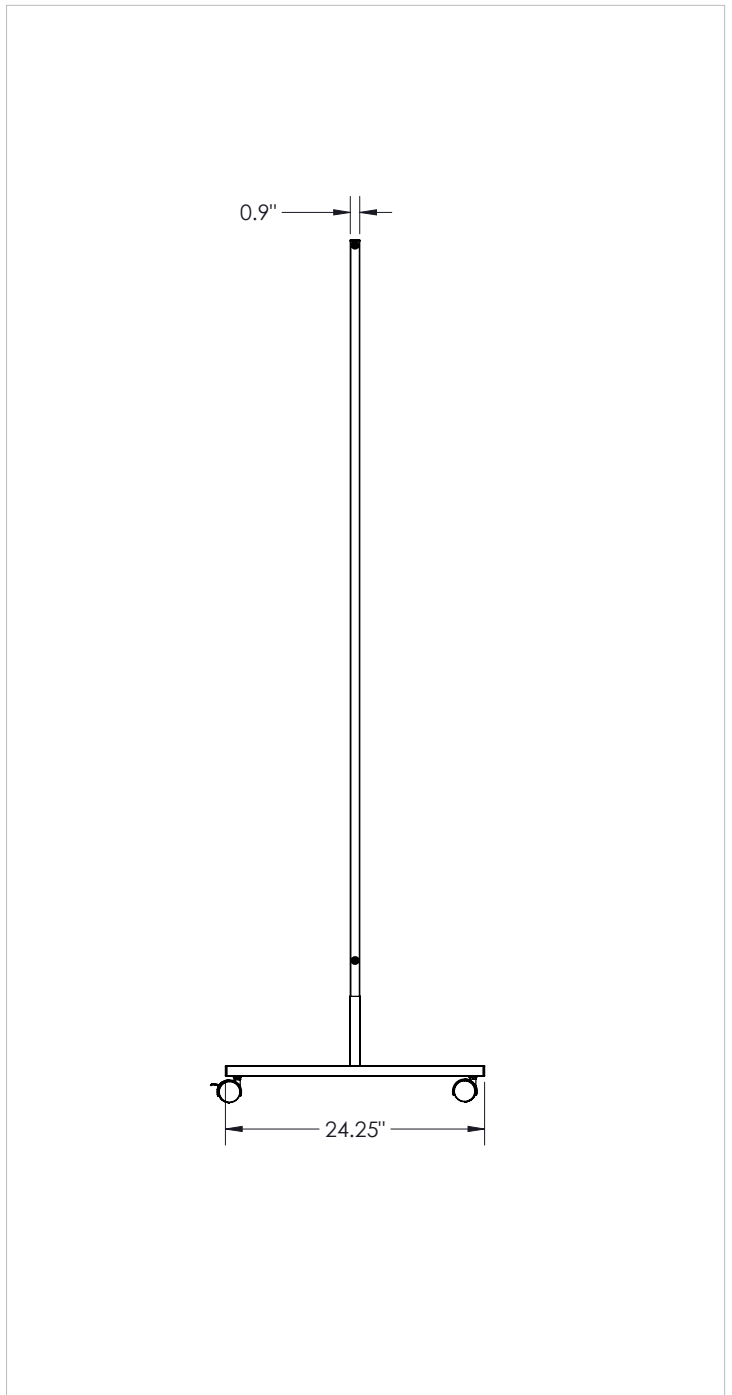
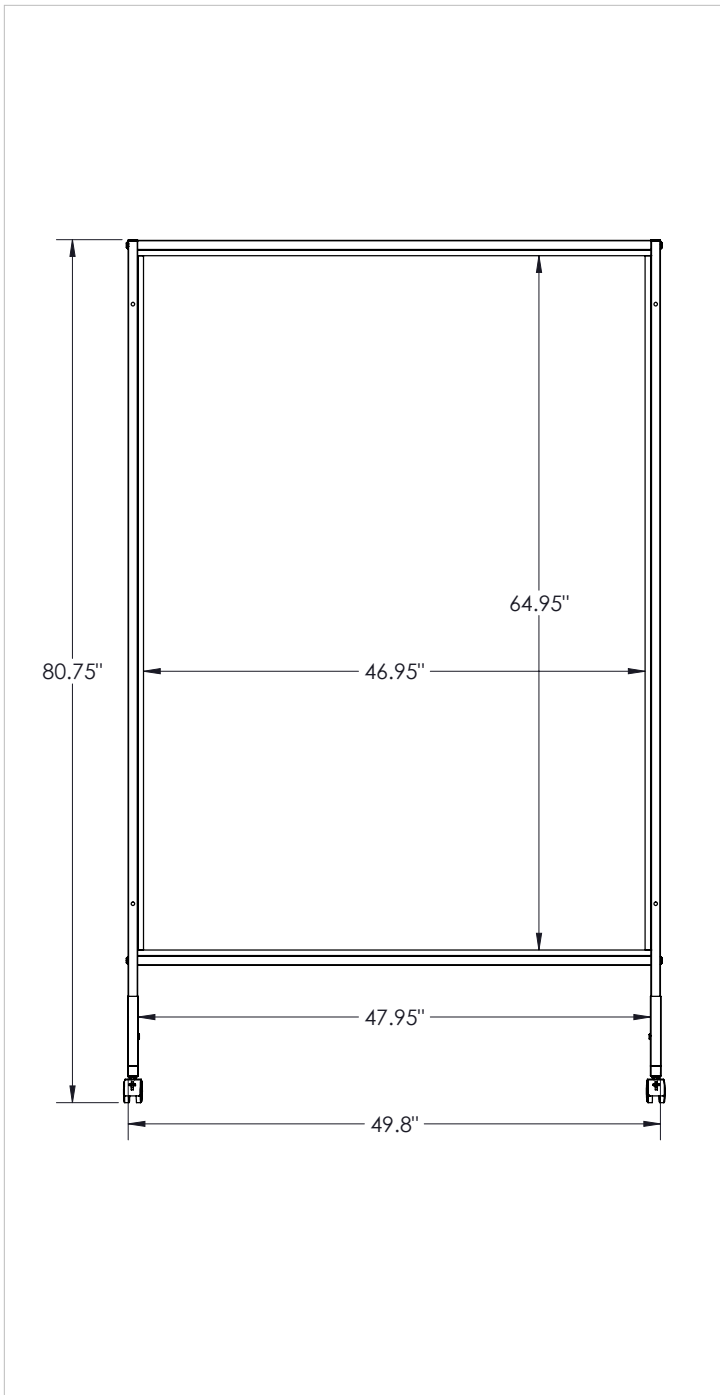

DIMENSIONS:

Base Model No.	Description	Overall Height "	Overall Width "	Overall Depth "
689D-XX	Single Mobile Floor Display Panel	80.75"	49.8"	24.25"