

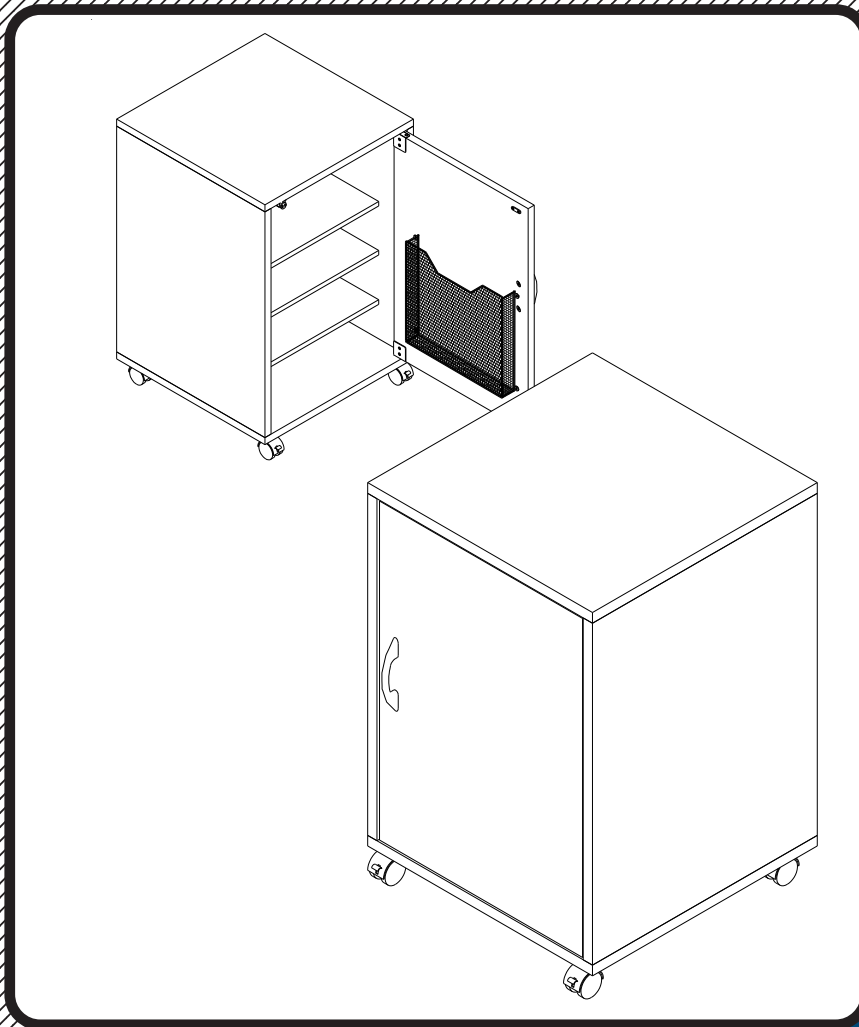









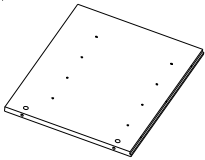
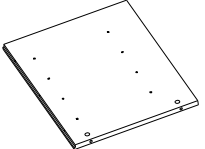

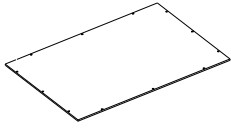
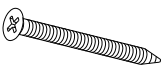
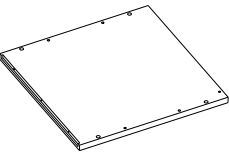

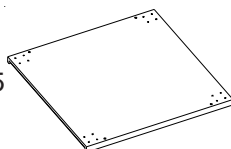
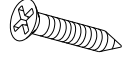
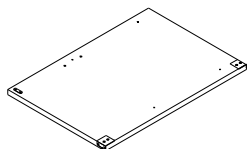

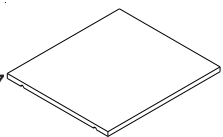
27502

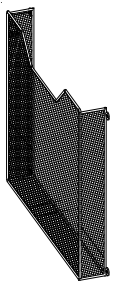
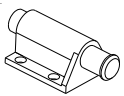
Single Fax Stand W/Paper Storage

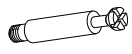

Assembly Instructions

27502

Part	Drawing	Description	Qty	Part	Drawing	Description	Qty
P-1		Left Side Panel	1 EA	Hardware List			
P-2		Right Side Panel	1 EA	A		#6 x 1/2" Wood Screw Pan Head	20 EA
P-3		Back Panel	1 EA	A1		#6 X 1 1/2" Wood Screw (Countersink Head)	4 EA
P-4		Top Panel	1 EA	A2		#6 x 5/8" Wood Screw (Countersink Head)	12 EA
P-5		Bottom Panel	1 EA	A3		#6 X 1" Wood Screw (Countersink Head)	2 EA
P-6		Door	1 EA	A4		#4 x 5/8" Wood Screw (Countersink Head)	4 EA
P-7		Removeable Shelf	3 EA	B		Metal Support Pins	12 EA
P-8		Wire Basket	1 EA	C		Magnetic Door Catch	1 EA
				D		2" Locking Caster (for front)	2 EA
				E		2" Caster (for Back)	2 EA
				F		Cam Lock	4 EA
				G		Cam Post	4 EA
				H		Rubber Washer	2 EA
				J		Wood Dowel	8 EA
				L		Door Handle	1 EA

27502 Assembly Diagram

Tools required: Phillips Head Screwdriver

Illustration # 1

To Assemble:

1. Identify and Separate all the Parts and Hardware.

2. Place the Left Side Panel (P-1) and the Right Side Panel (P-2) with the Predrilled holes facing up and install 2 Cam Locks (F) into the large holes in each Panel as shown in illustration # 1.

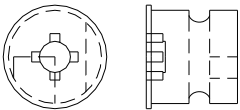
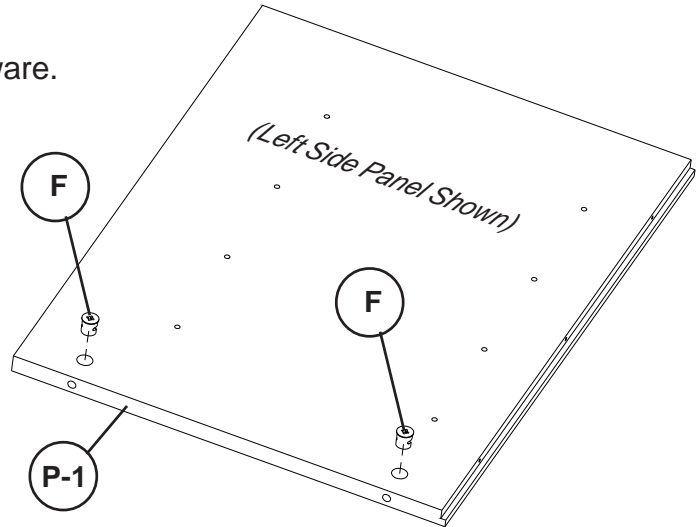

(F) CamLock
For Scale only

3. Place the Top Panel (P-4) with the Holes facing up. Attach 1 Magnetic Door Catch (C) to the Top Panel (P-4) using 4 each Wood Screws (A4) as shown in illustration # 2.

4. Install 4 each Cam Posts (G) in the 4 threaded insert nuts (Pre-installed) as shown in illustration # 2.

5. Install 4 each Wood Dowels (J) into the drilled holes as shown in illustration # 2.

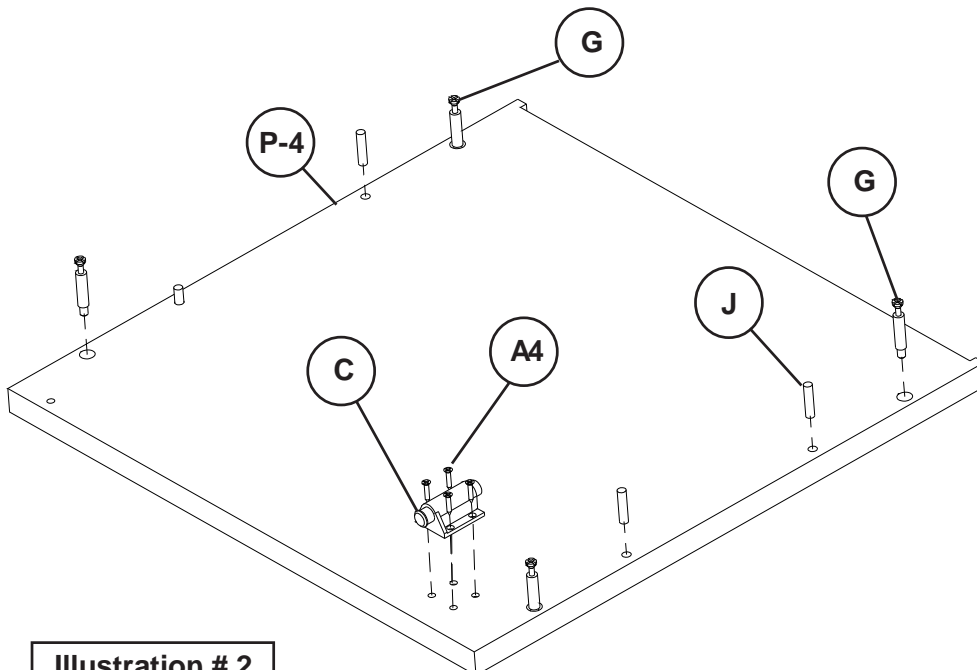
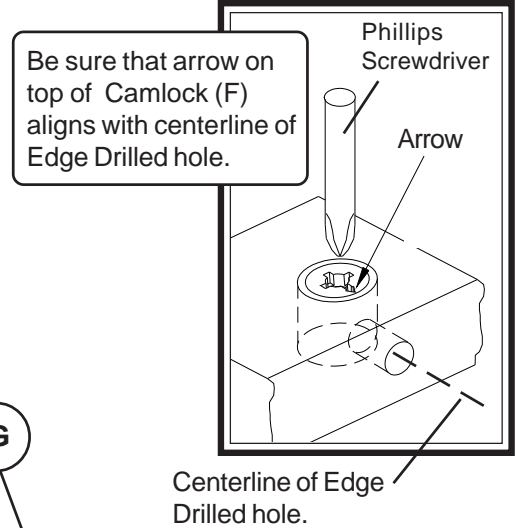
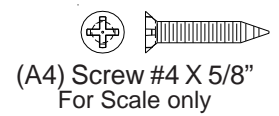

Illustration # 2



Centerline of Edge Drilled hole.



(A4) Screw #4 X 5/8"
For Scale only

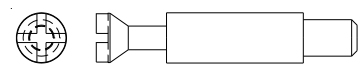

(G) Cam Post
For Scale only



(J) Wood Dowel
For Scale only

6. Attach 2 Locking Plate Casters (D) and 2 Plate Casters (E) to the Bottom Platform (P-5) using 16 screws (A).

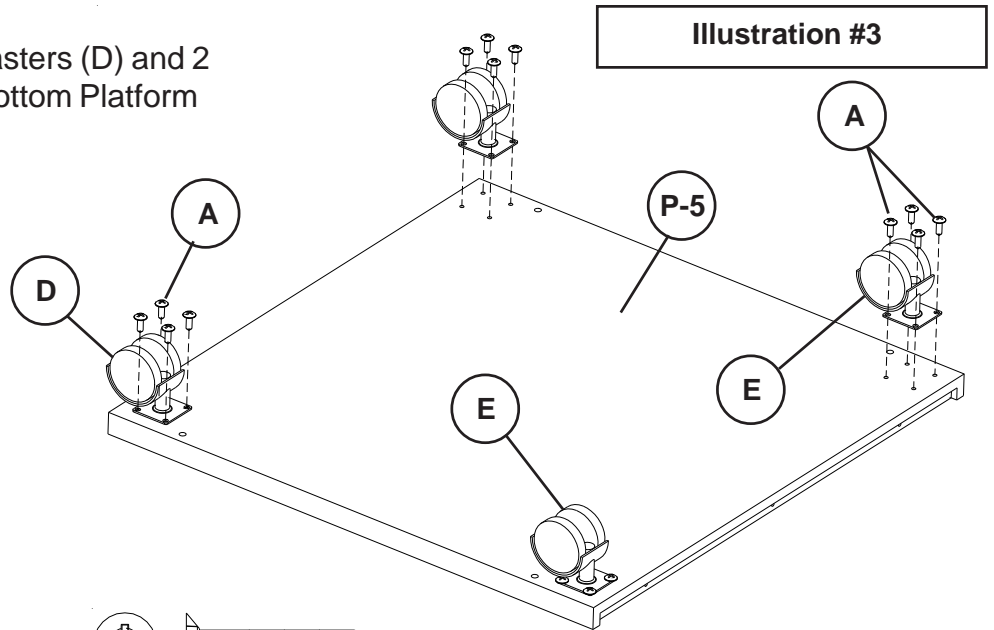
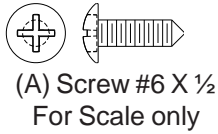

7. Attach Door Handle (L) to Door (P-6) using 2 each (A-3) screw as shown in illustration #4.

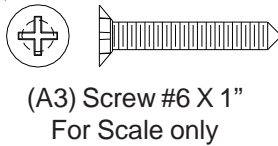

8. Attach the Wire Basket (P-8) to the Door (P-6) using 4 each screws (A) as shown in illustration #4.

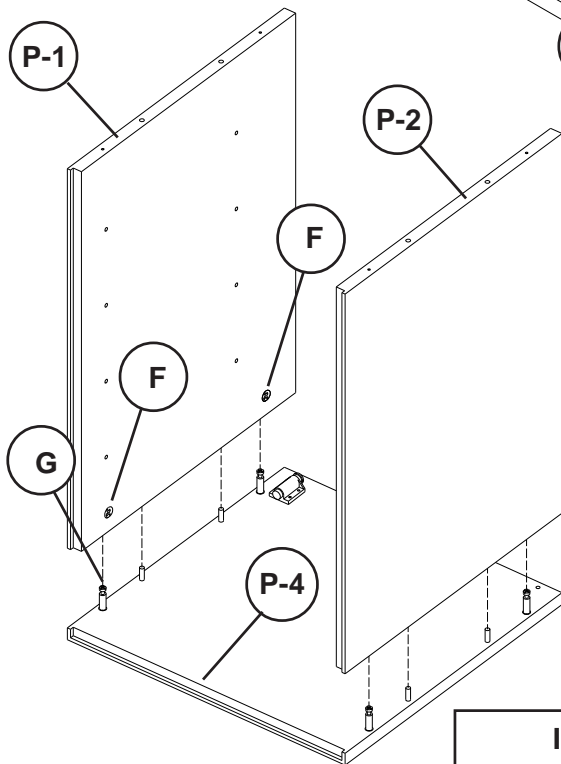
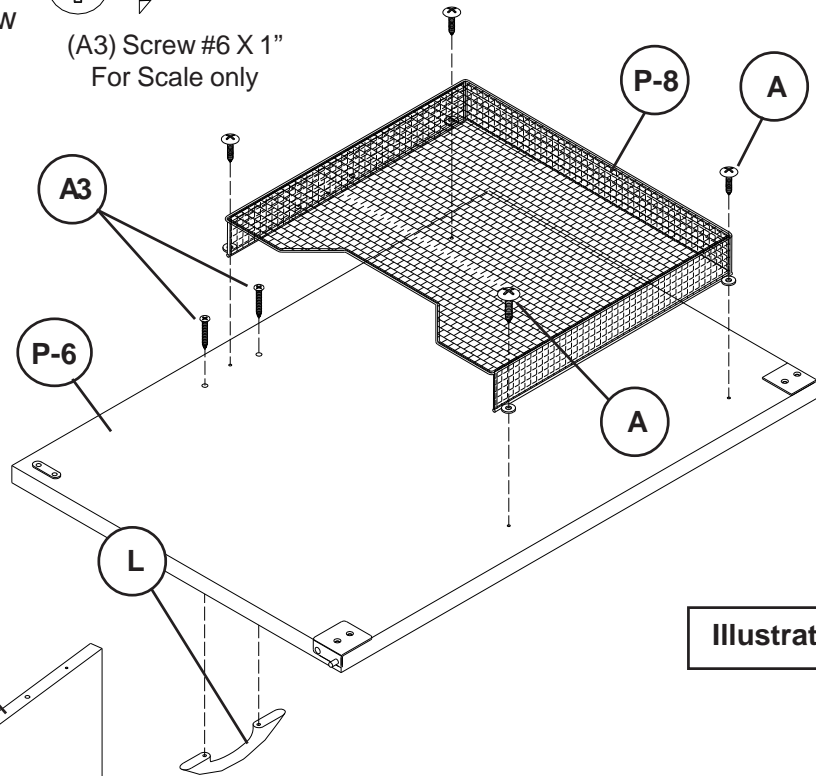
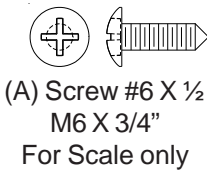

To Secure Cam Locks, Insert Large Phillips Head Screwdriver and turn Cam Lock 1/4 turn (90 degrees) clockwise.

9. Attach Left Side Panel (P-1) and the Right Side Panel (P-2) to the Top Panel (P-4) as shown in illustration #5. Secure by turning the Cam Locks (F) 1/4 turn until they lock.

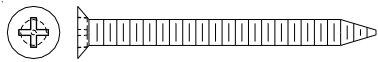

(A1) Screw #6 X 1½"
For Scale only

Illustration #6

10. Install 4 each Wood Dowels (J) into the drilled holes in the Left Side Panel (P-1) and the Right Side Panel (P-2), as shown in illustration # 6.

11. Place 2 Rubber Washers (H) over Steel Pins in bottom and top for Door (P-6) as shown in illustration #6.

12. Slide Bottom Platform (P-5) over the 4 each Wood Dowels(J) and Secure using 4 each Wood Screws (A1) as shown in illustration #6.

13. Place 6 Shelf Support Pins (B) in the Left Side Panel (P-1) and the Right Side Panel (P-2) at desired shelf height.

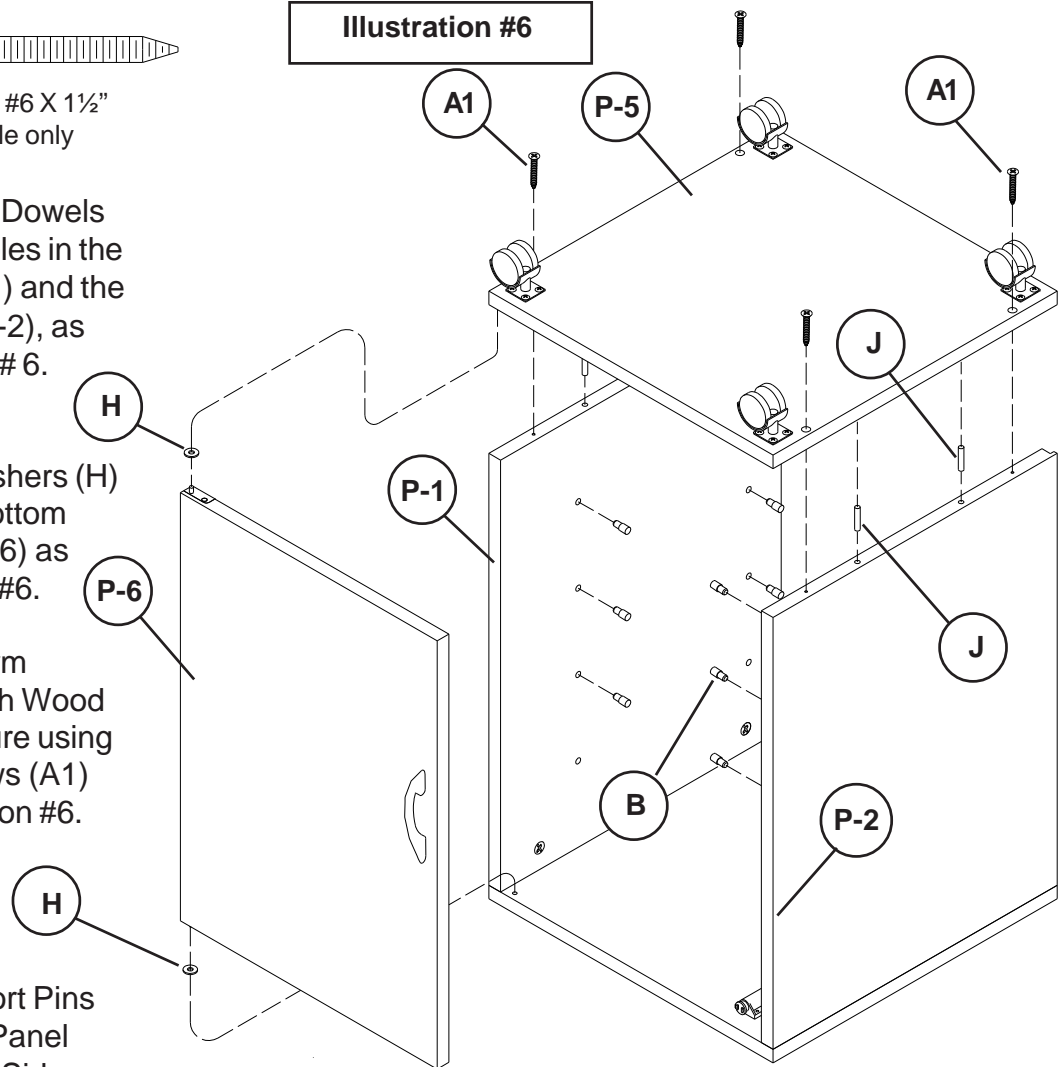

(A2) Screw #6 X 5/8"

14. Insert Back Panel (P-3) in the groove in the Left Side Panel (P-1), the Right Side Panel (P-2), Bottom Panel (P-5), and the Top Panel (P-4). Secure using Back Panel (P-3) using 9 Screws (A2) as shown in illustration #7.

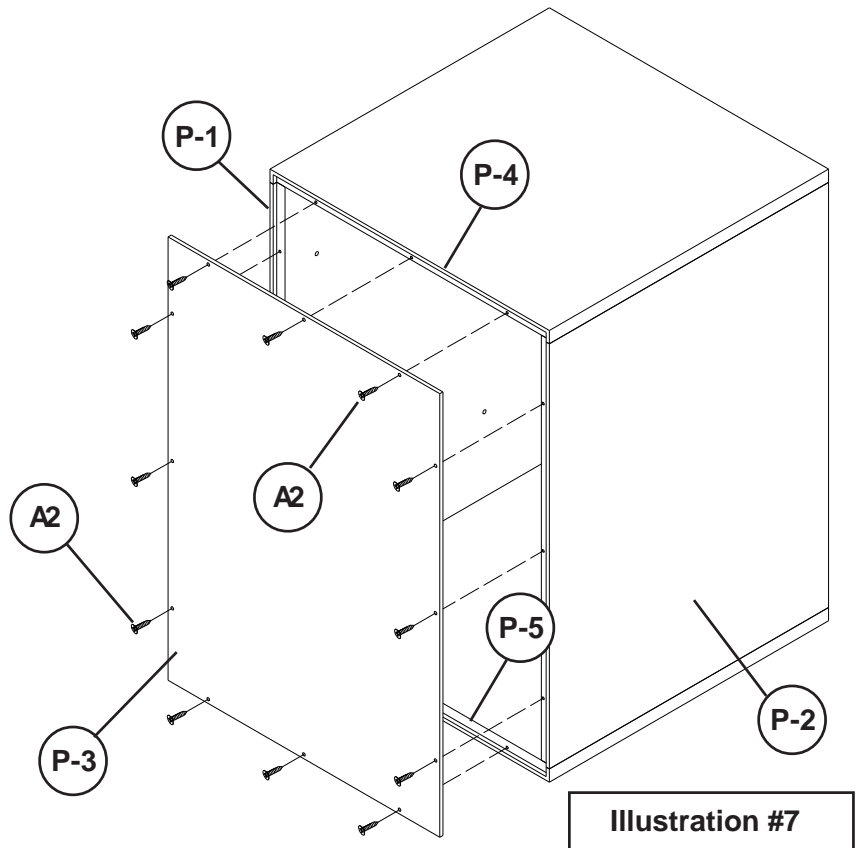

Illustration #7

15. Angle Removable Shelf (P-7) and slide through the front of unit, placing it on four Shelf Support Pins (B) as shown in illustration #9.

16. Repeat Step 17 for 2 other Removable Shelves (P-7).

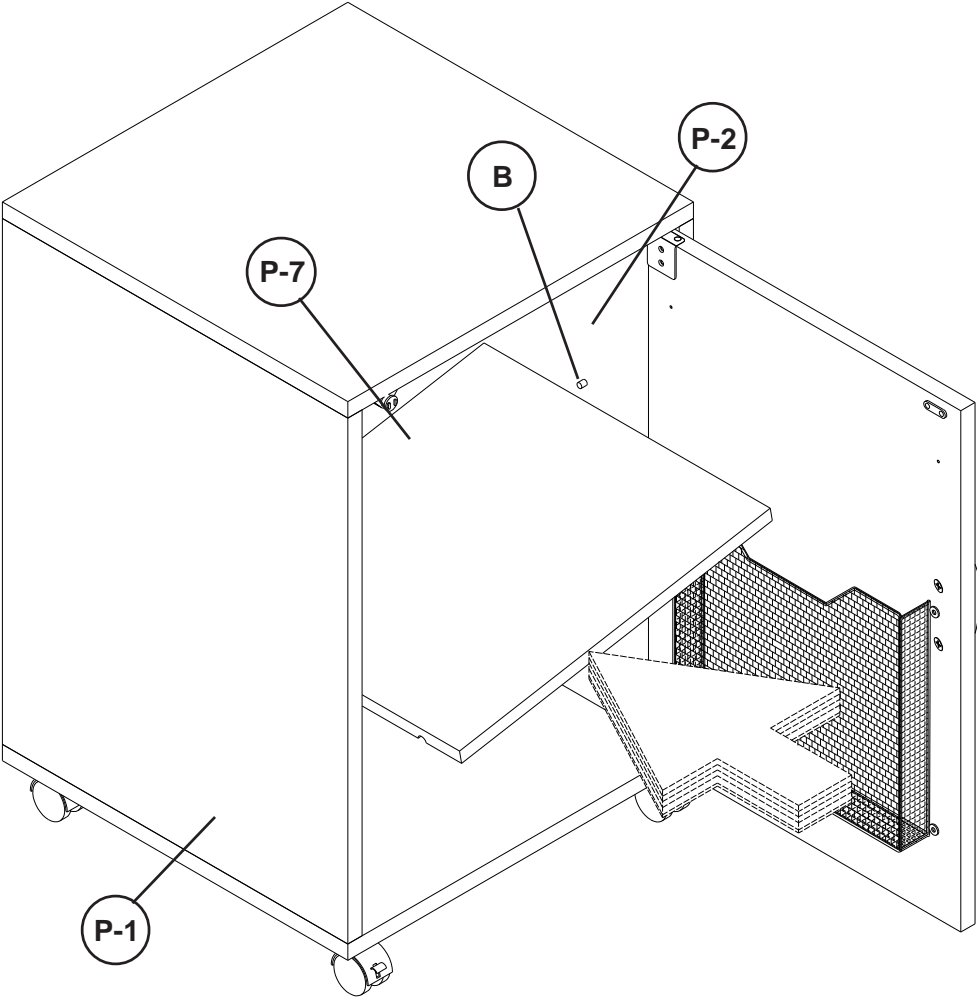
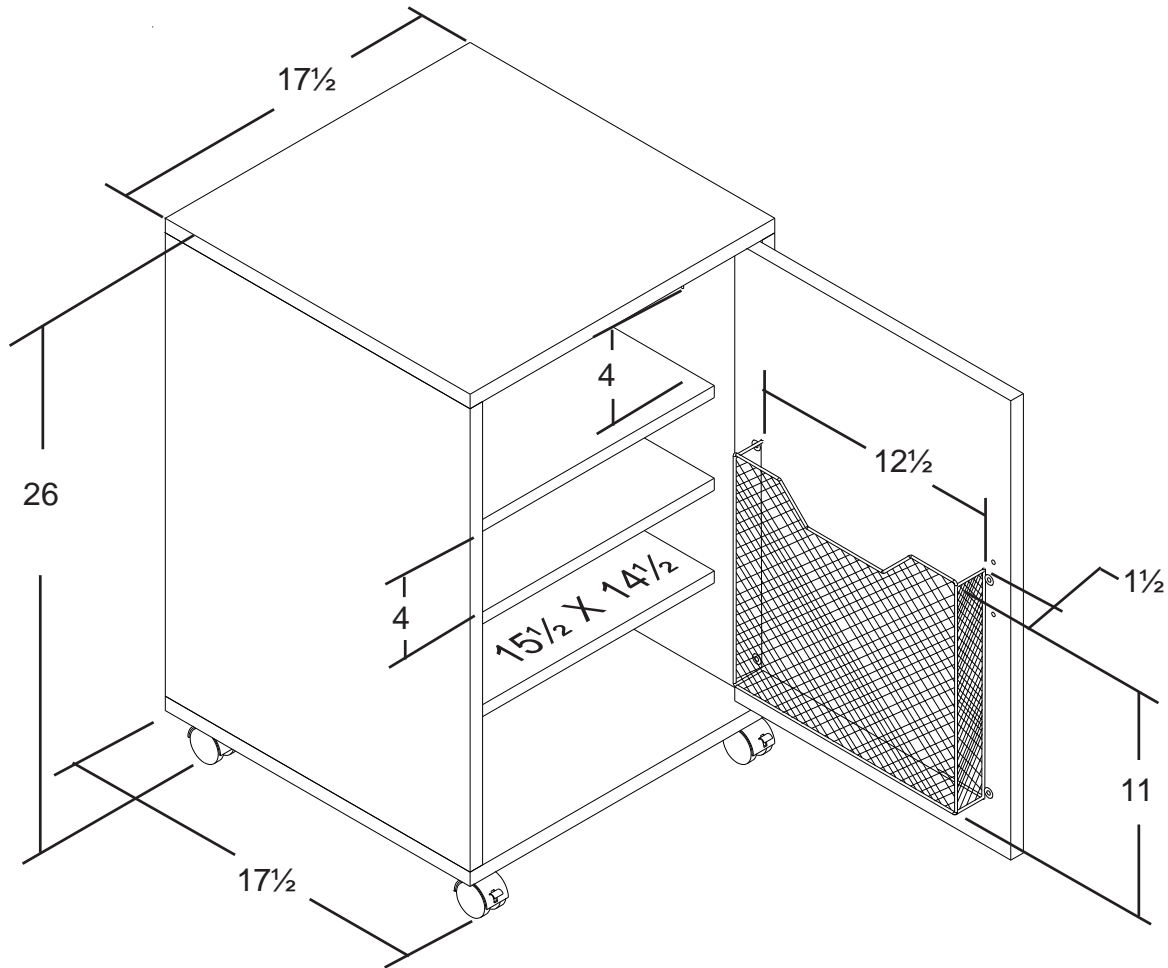

Illustration #9

27502

Single Fax Stand w/Paper Storage



Shipping Information

2.5 Cubic Feet

57 lbs.

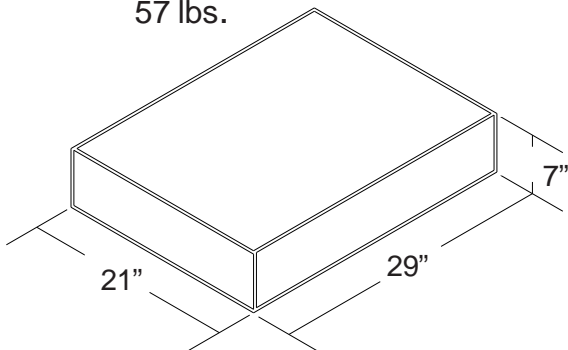

Includes 2" Casters for mobility.

Available in Gray Laminate.

Ships UPS.