

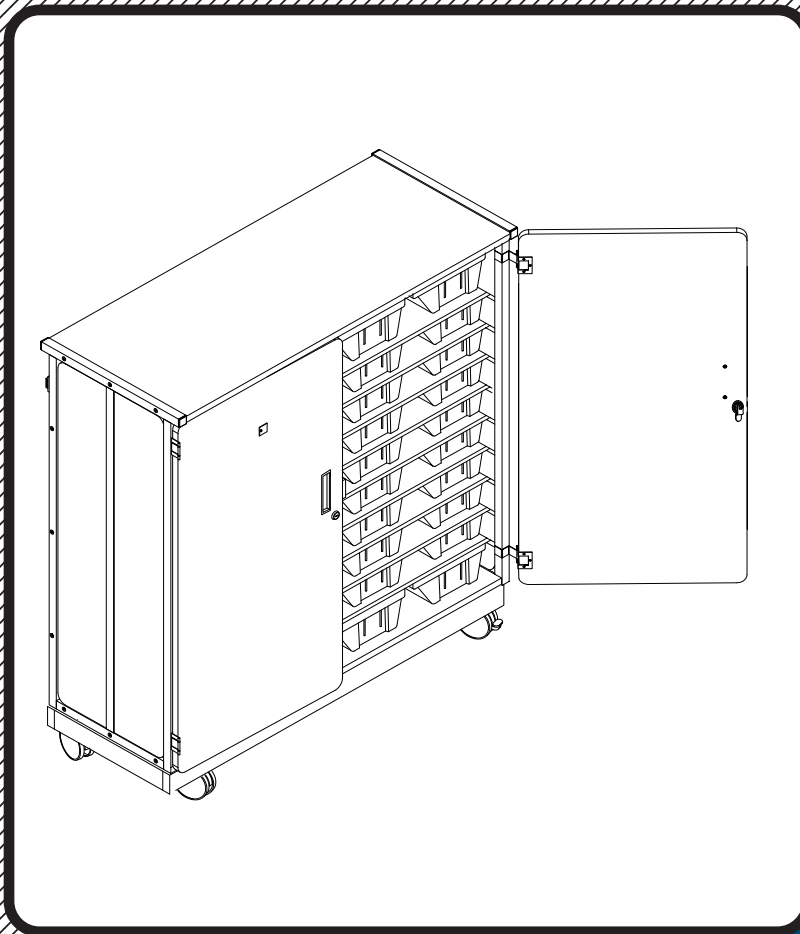

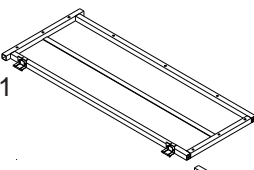

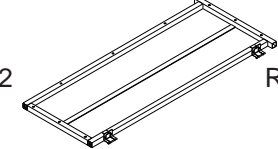

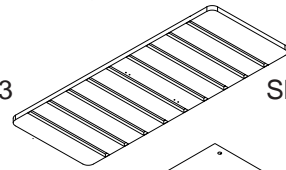

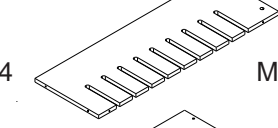
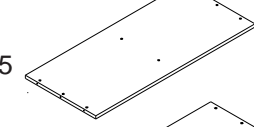
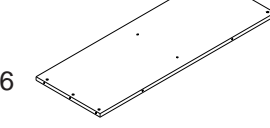
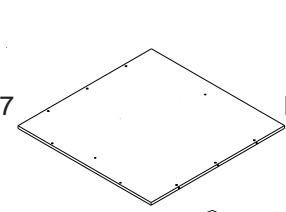
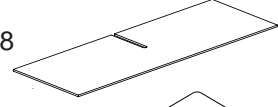
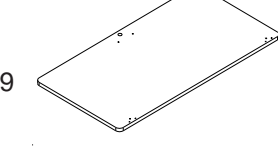
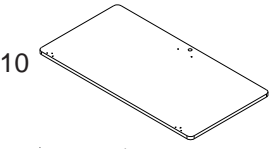
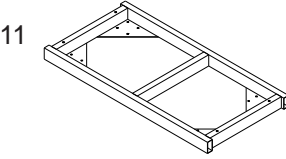

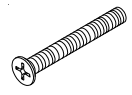
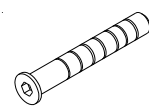

27736



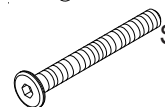

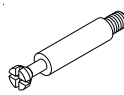
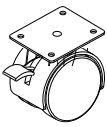
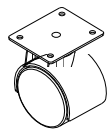
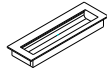

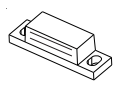

Mobile 40 Tub Storage Cart

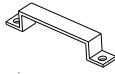
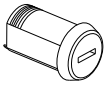

Assembly Instructions

Part	Drawing	Description	Ctn.	Qty
P-1		Left Leg Welded *	1	EA
P-2		Right Leg Welded *	1	EA
P-3		Slotted End Panel *	2	EA
P-4		Middle Panel #	1	EA
P-5		Top Panel #	1	EA
P-6		Bottom Panel #	1	EA
P-7		Back Panel #	1	EA
P-8		Shelf */#	9	EA
P-9		Left Door #	1	EA
P-10		Right Door #	1	EA
P-11		Caster Base *	1	EA

Part	Drawing	Description	Ctn.	Qty
Hardware List				
A		Phil Screw M6X15mm *	16	EA
A1		CS Phil Screw M6X50mm *	18	EA
A2		Wood Screw M7x50mm *	7	EA
A3		CS Wd Screw M3x12mm *	12	EA
A4		Phil Pan Screw M4x12mm *	4	EA
A5		(Door Knobs) Pan Wd Screw M4x18mm *	6	EA
A6		Socket Screw M6x65mm *	4	EA
A7		Small CS Screw *	2	EA
C1		Cam Lock *	2	EA
C2		Cam Post *	2	EA
D		Locking Caster *	2	EA
E		Non-Locking Caster *	2	EA
F		Door Handle *	2	EA
G		Wood Dowel *	1	EA
H		Magnet *	2	EA
I		Metal Plate *	2	EA

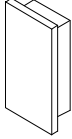
Part	Drawing	Description	Ctn.	Qty
Hardware List				
J		Lock Catch	*	1 EA
K1		Lock Cylinder	*	2 EA
K2		Lock Washer	*	2 EA
K3		Lock Hex	*	2 EA
K4		Lock Retainer	*	2 EA
K5		1/4" Phil Head Lock Screw	*	2 EA
L		Key	*	4 EA
N		Allen Wrench	*	1 EA
O		Small Tube Closure	*	4 EA
P		Large Tube Closure	*	4 EA

NOTE: 27736 Mobile 40 Tub Storage Cart comes in two boxes
58468 Box 1 = #
58469 Box 2 = *

Assembly Diagram

To Assemble:

1. Identify and Separate all the Parts and Hardware.
2. Install 2 each Cam Posts (C2) in the 2 threaded insert nuts in the Top Panel (P5) as shown in illustration #1.

Illustration # 1

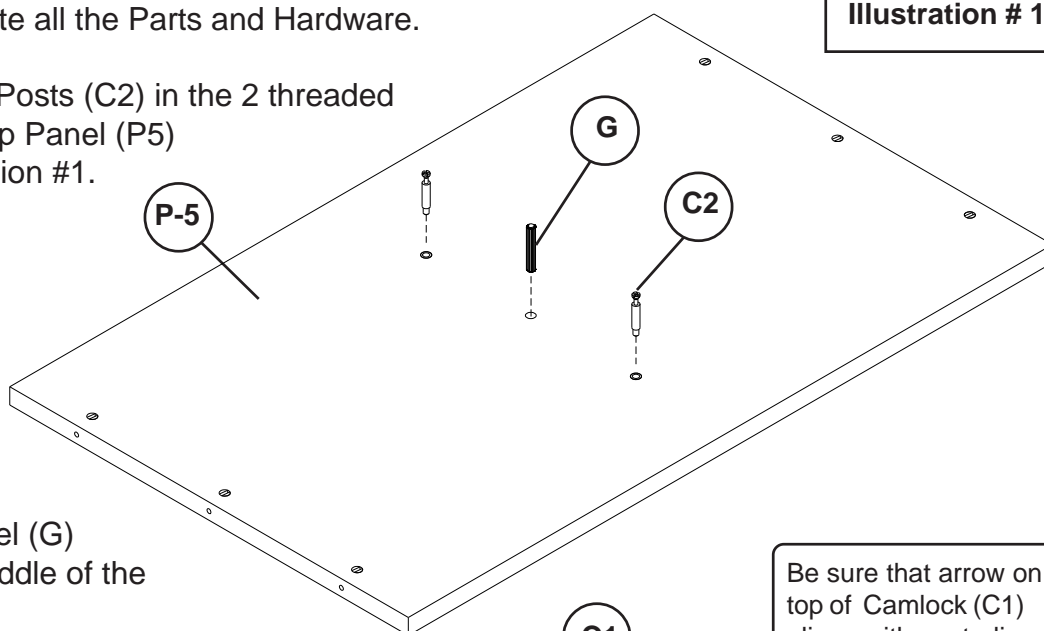

3. Install 1 Wood Dowel (G) in the hole in the middle of the Top Panel (P5)
4. Install 2 Cam Locks (C1) into the 2 large holes in the Middle Panel (P4) as shown in illustration #2

Be sure that arrow on top of Camlock (C1) aligns with centerline of Edge Drilled hole.

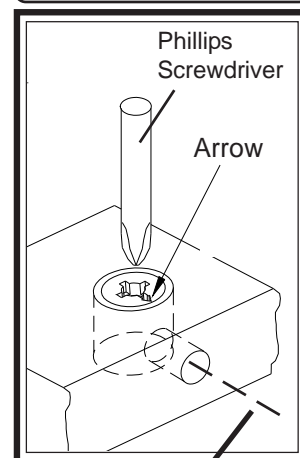

Centerline of Edge Drilled hole.

Illustration # 2

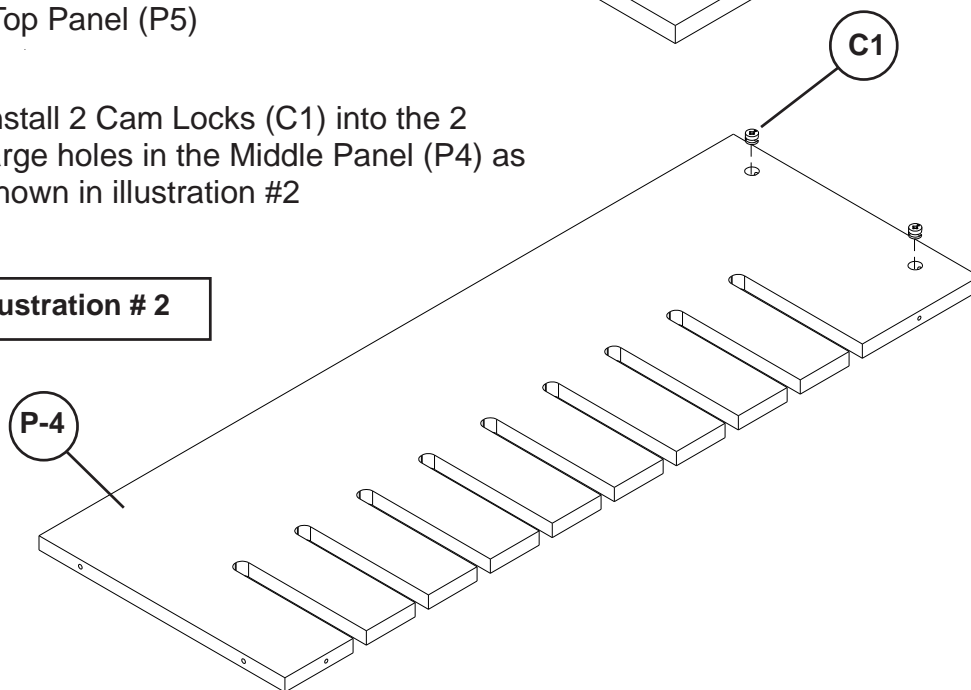

5. Attach Middle Panel (P4) to the Top Panel (P5) as shown in illustration #3. Secure by turning the Cam Locks (C1) 1/4 Turn until they lock.

6. Attach Bottom Panel (P6) to the Middle Panel (P-4) using 2 Wood Screws (A2).

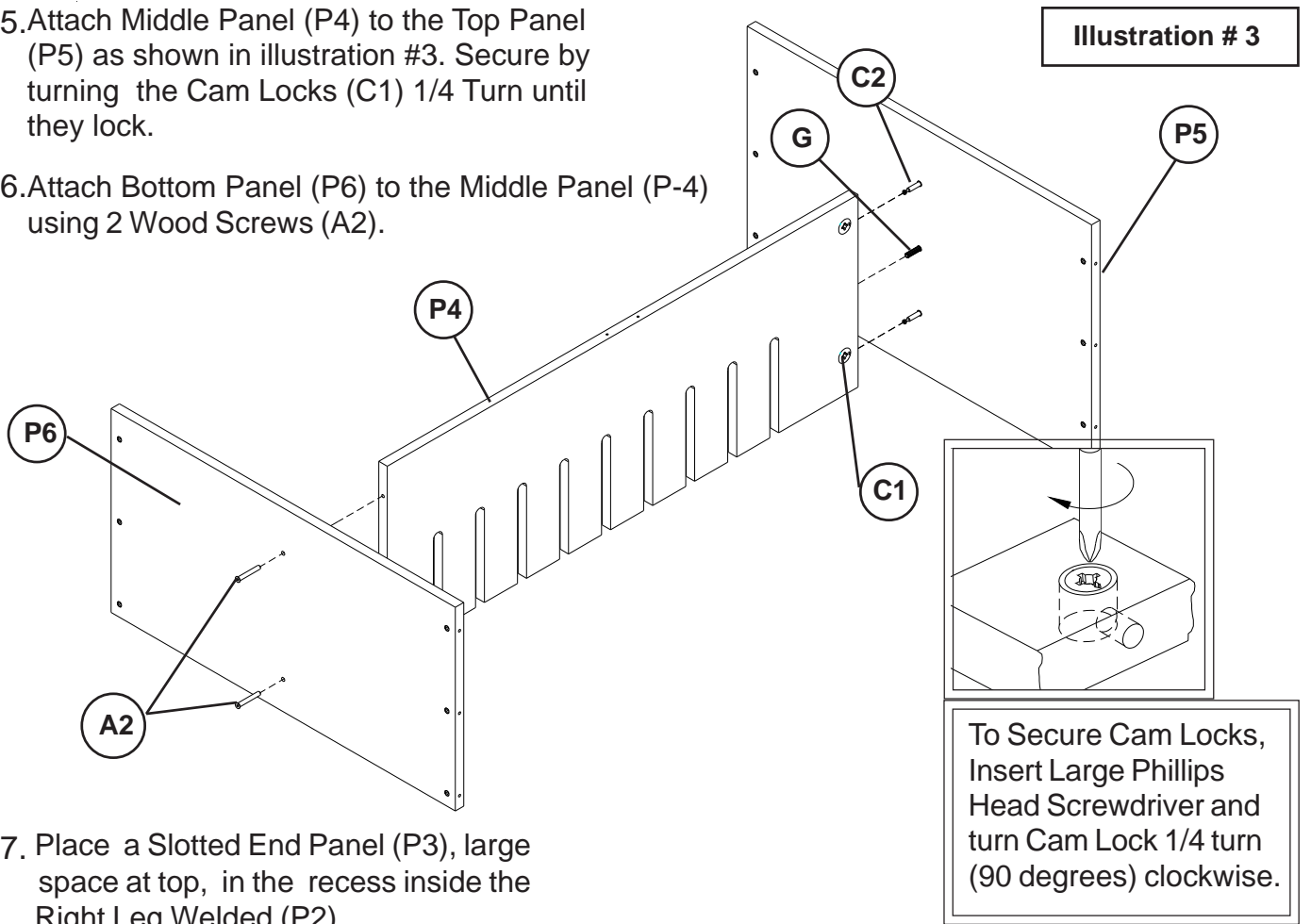

7. Place a Slotted End Panel (P3), large space at top, in the recess inside the Right Leg Welded (P2). Attach Right Leg Welded (P2) to the Top and Bottom Panels (P5 & P6) using 6 CS Phil Screws (A1) as shown in illustration #4. Just start the CS Phillips Screws (A1) at this point and do not tighten.

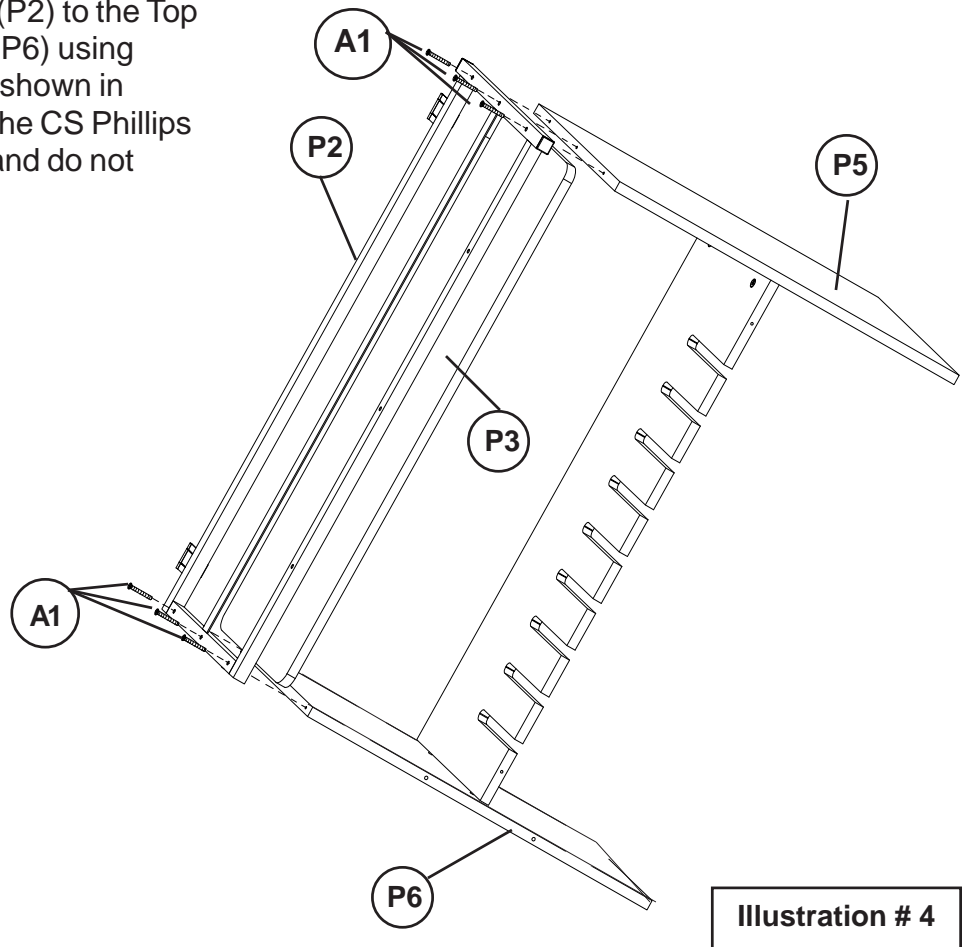

Illustration # 5

8. Slide 9 Shelves (P8) over Middle Panel (P4) and into slots in Slotted End Panel (P3) as shown in illustration #5.

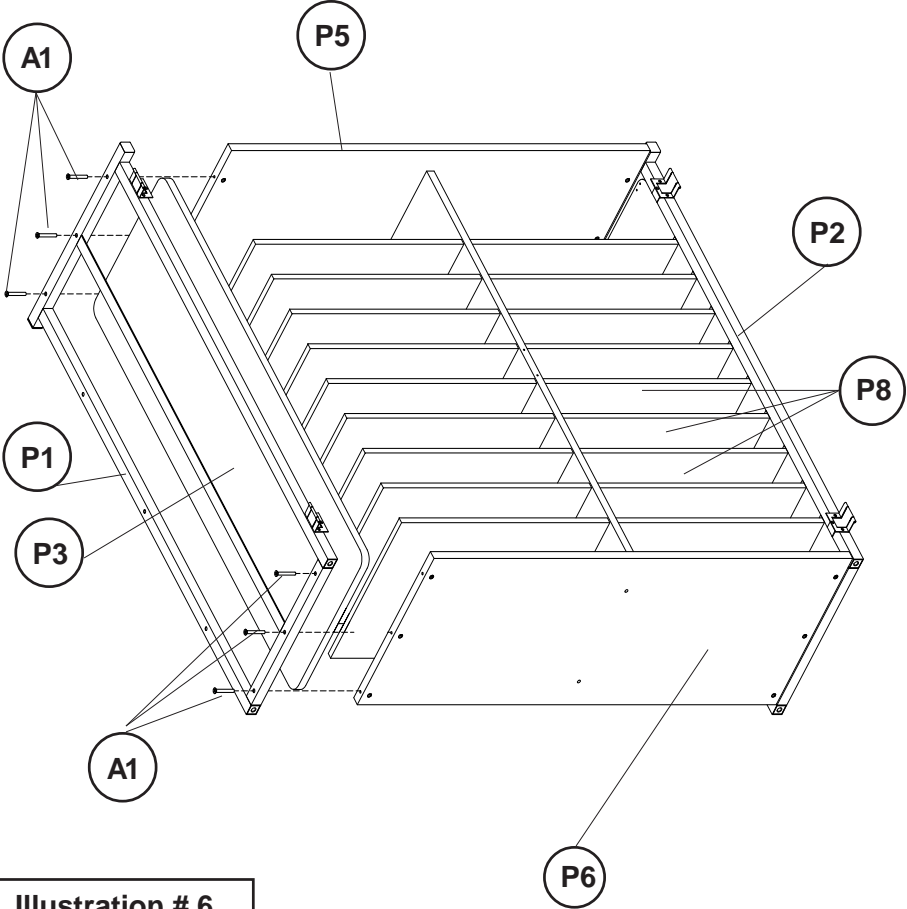
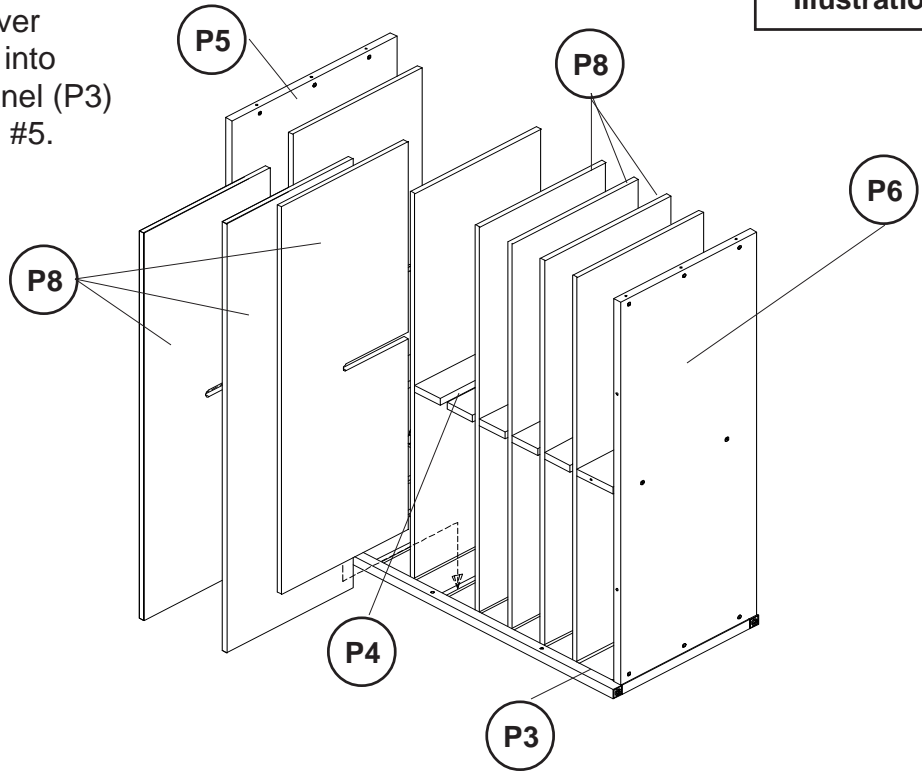

Illustration # 6

9. Place Slotted End Panel (P3) over the end of 9 Shelves (P8) as shown in illustration #6.

10. Attach Left Leg Welded (P1) to the Top and bottom Panels (P5 & P6) using 6 CS Phil Screws (A1) .

13. Place the Left Door (P9) with the Predrilled (for Hinges) holes facing up and Insert 1 each Lock Cylinder (K1) through the hole in the Left Door (P9) as shown in illustration # 7. Secure Lock Cylinder (K1) using the Lock Washer (K2) and the Lock Hex (K3).
(FINGER TIGHTEN ONLY.)

14. Slide Lock Retainer (K4) over the square end of Lock Cylinder (K1). Secure using the ¼" Phil Head Lock Screw (K5).

Illustration # 7

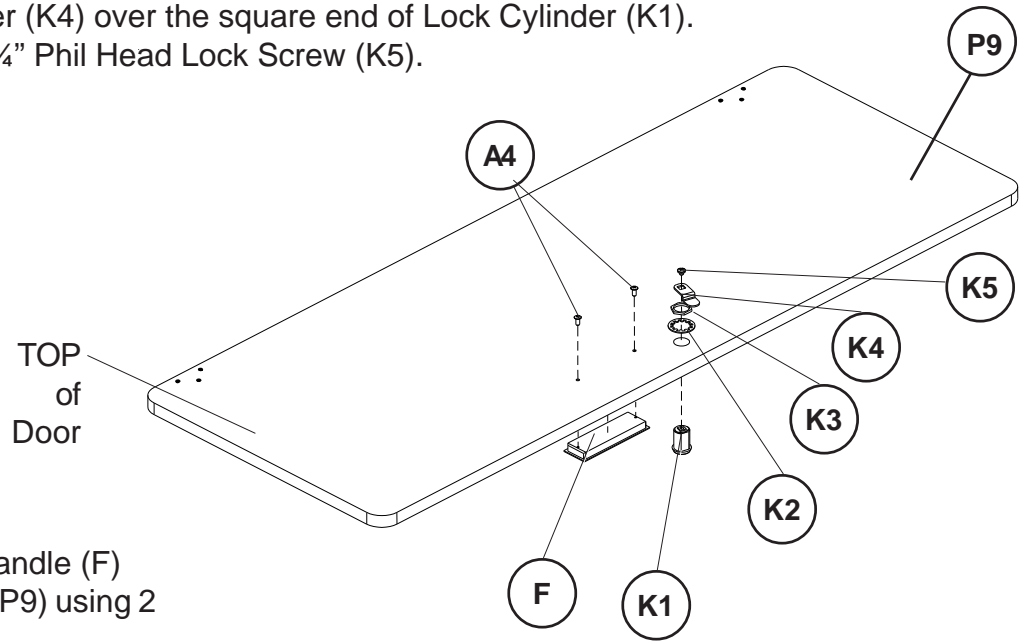

15. Attach 1 Door Handle (F) to the Left Door (P9) using 2 Screws (A4).

16. Place the Right Door (P10) with the Predrilled holes facing up and Insert 1 each Lock Cylinder (K1) through the hole in the Right Door (P10). Secure Lock Cylinder (K1) using the Lock Washer (K2) and the Lock Hex (K3).
(FINGER TIGHTEN ONLY.)

17. Slide Lock Retainer (K4) over the square end of Lock Cylinder (K1). Secure using the ¼" Phil Head Lock Screw (K5).

Illustration # 8

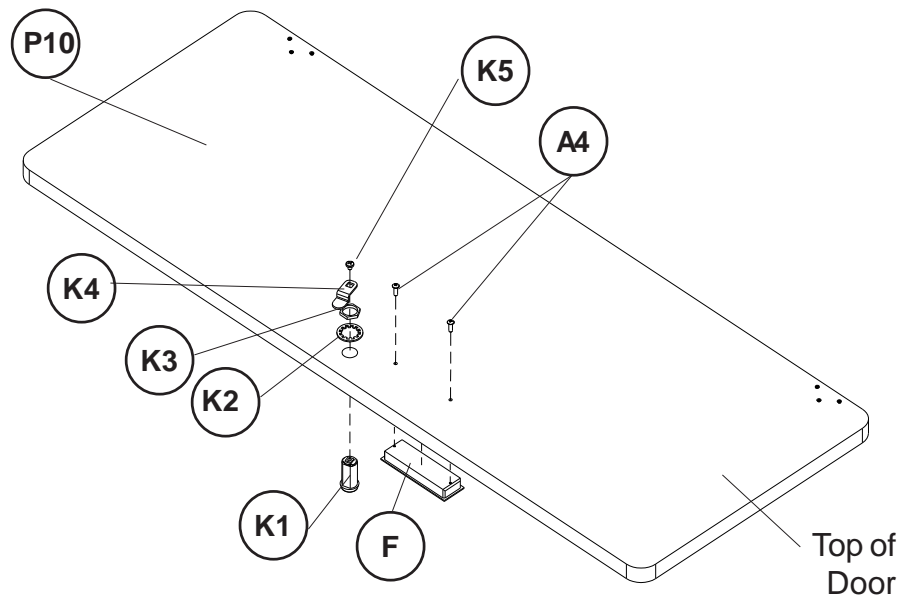

18. Attach 1 Door Handle (F) to the Right Door (P10) using 2 Screws (A4).

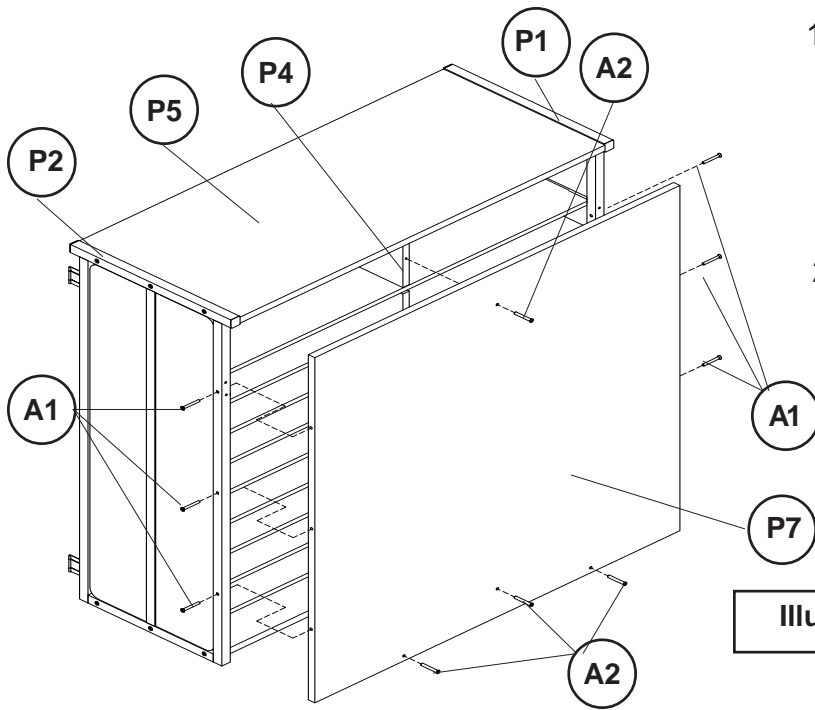

19. Attach Back Panel (P7) to the Left Leg Welded (P1), and the Right Leg Welded (P2) using 6 screws (A1) as shown in illustration #9.
20. Secure Back Panel (P7) to the Middle Panel (P4) and the Bottom Panel (P6) using 4 Screws (A2).

Illustration # 9

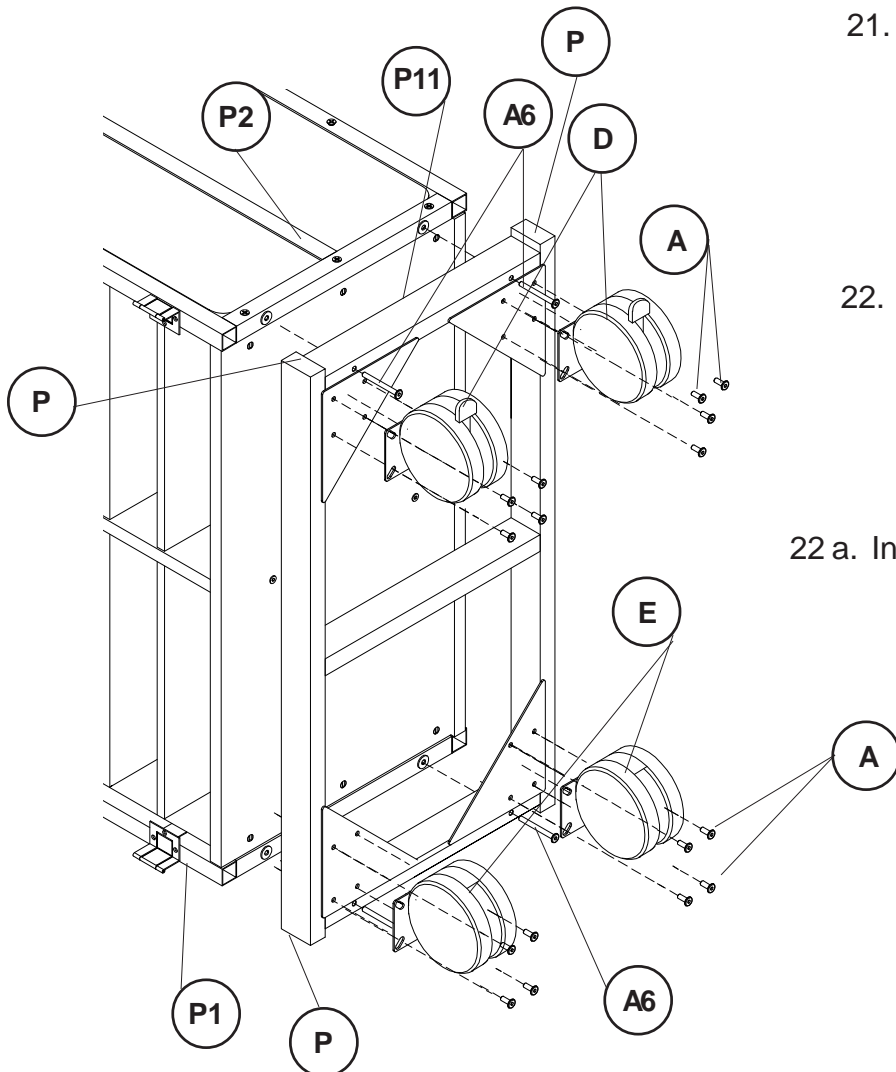

21. Attach Caster Base (P11) to the Welded Legs (P1 & P2) using 4 each screws (A6) as shown in illustration #10. *Tighten these 4 Screws using Allen Wrench (R).*

22. Attach 2 locking Casters (D) and 2 Inline Casters (E) to metal base (P-1) using 16 screws (A). Tighten Screws Allen Wrench (N) as shown in illustration #10.

- 22 a. Install four Large Tube Closures (P) into the Base (P-11) as shown.

Illustration # 10

23. Attach Left Door (P9) to Left Leg welded (P1) using 6 screw (A3) as shown in illustration #11 and Detail #11A.

Illustration # 11

24. Attach Lock Catch (J) to Middle Panel (P4) using 2 screw (A5) . See Detail #15A.

25. Attach Right Door (P10) to Right Leg Welded (P2) using 6 screw (A3) as shown in illustration #12 &12A.

Detail # 11A

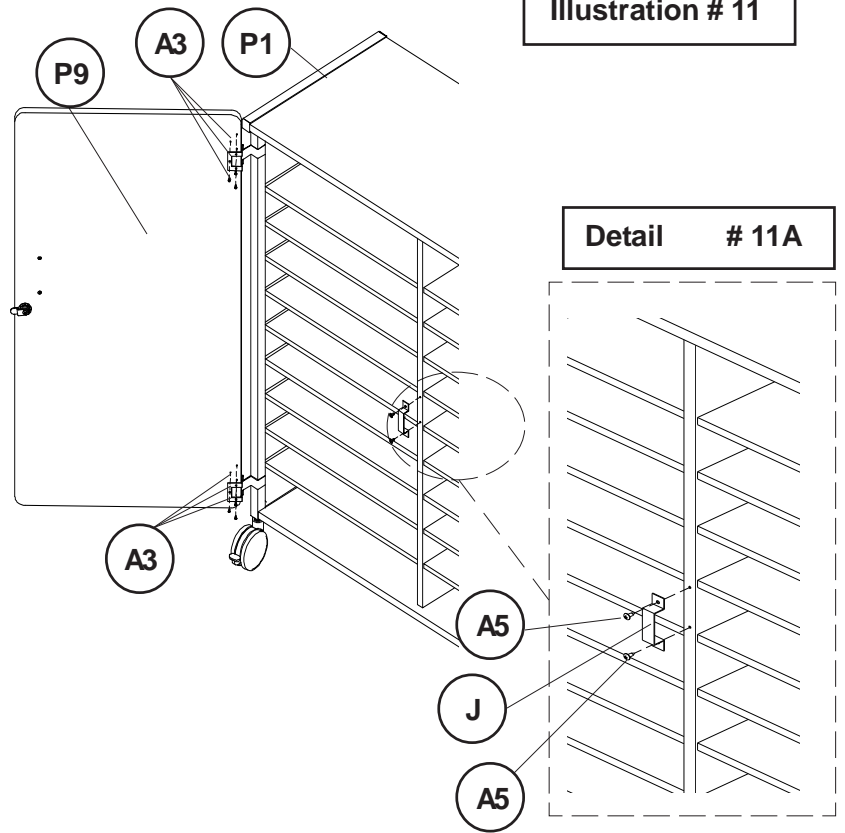

26. Before tightening the Lock Hex (K3) on either door, insert the Key (L) and turn lock. Be sure that Lock Retainer (K4) turns 90 degrees and rotates behind Door Stop (J).

TIGHTEN LOCK HEX (K3). SEE ILLUSTRATION # 7 & # 8.

26 a. Install four Small Tube Closures (O) into the ends of the top Leg tubes.

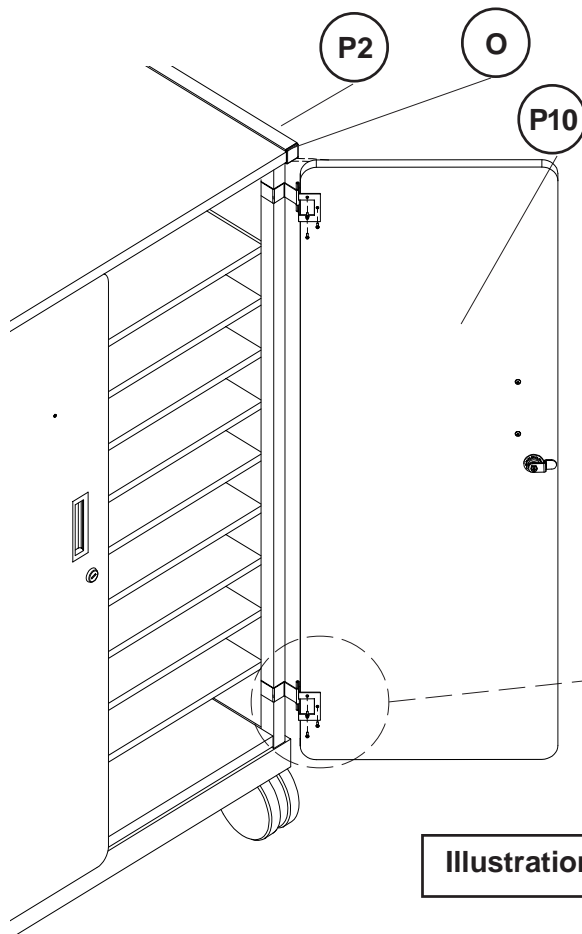
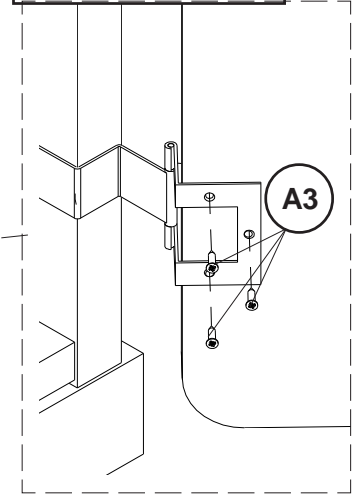

Illustration # 12

Detail # 12A



27. Attach Magnet (H) on the back at the top of each Leg Weld assembly using two Screws (A5) and into the punched holes. Attach a Metal Plate (I) to the front of each Door using a CS Screw (A7) as shown in illustration #13.

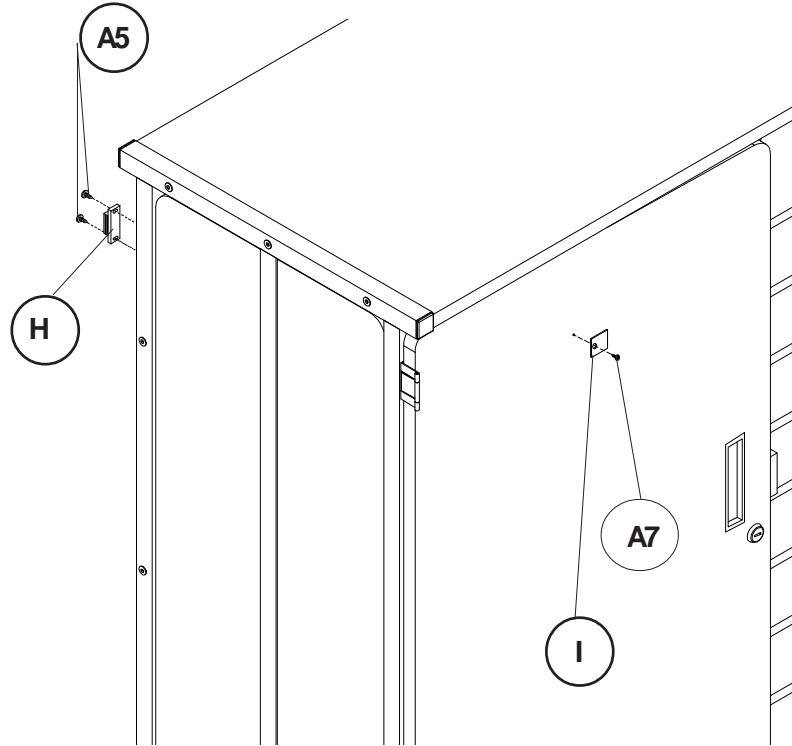

Illustration # 13

27736

Mobile 40 Tub Storage Cart

