

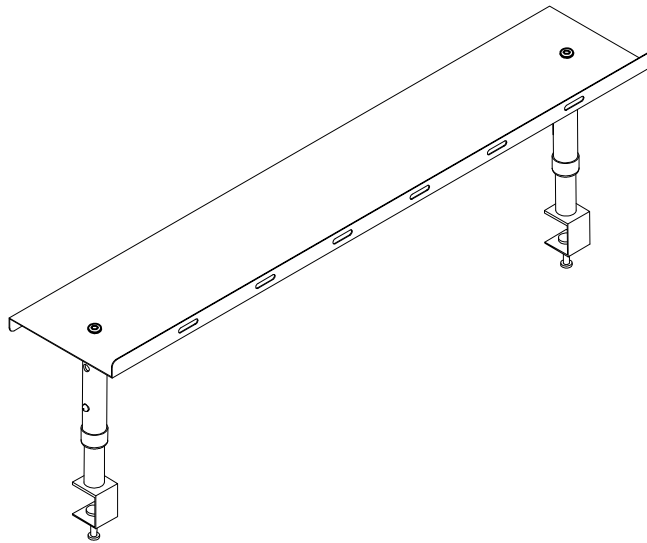

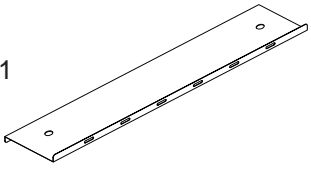







# 66635 Accessory Shelf



## Assembly Instructions

# Accessory Shelf

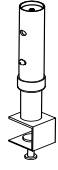
Part	Drawing	Description	Qty	Part	Drawing	Description	Qty												
P1		Shelf	1 EA	<div style="border: 2px solid black; border-radius: 15px; padding: 10px; text-align: center;"> <h3>Hardware List</h3> <table border="0"> <tr> <td>A</td> <td></td> <td>Screw M6X28mm</td> <td>2 EA</td> </tr> <tr> <td>B</td> <td></td> <td>Allen Wrench</td> <td>1 EA</td> </tr> <tr> <td>C</td> <td></td> <td>Velcro Straps</td> <td>2 EA</td> </tr> </table> </div>				A		Screw M6X28mm	2 EA	B		Allen Wrench	1 EA	C		Velcro Straps	2 EA
A		Screw M6X28mm	2 EA																
B		Allen Wrench	1 EA																
C		Velcro Straps	2 EA																
P2		Adjustable Post	2 EA																

# Assembly Instructions

**READ THROUGH INSTRUCTIONS FROM BEGINNING TO END BEFORE STARTING TO ASSEMBLE UNIT.**

- 1.) Identify and Separate all the Parts and Hardware.
- 2.) Attach the Shelf (P1) to each Adjustable Post (P2) using one Screw (A) in each as shown in Illustration #1. Tighten the Screws (A) using Allen Wrench (B).

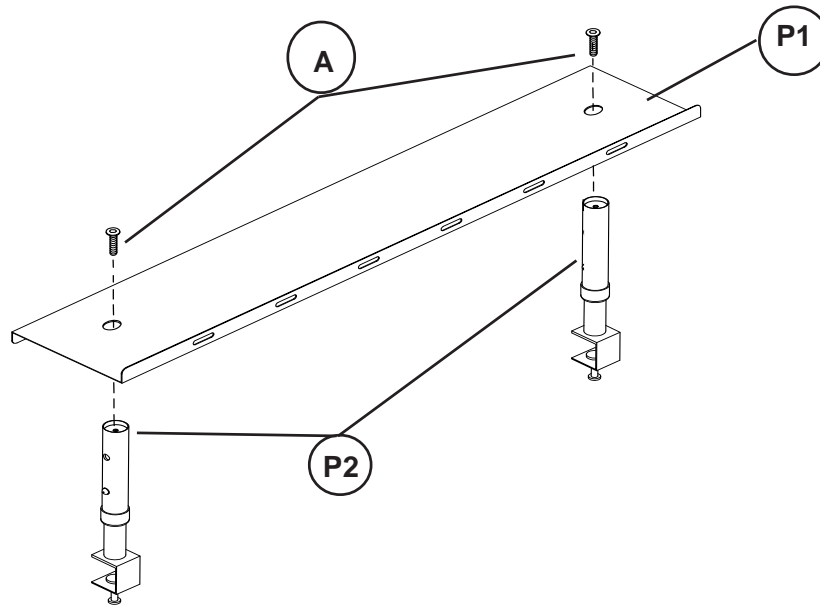

- 3.) Hook the clamps on the bottom of the Adjustable Posts (P2) over the top tube on the back frame. Tighten the screw clamps with Allen Wrench (B). Place the Straps (C) through the slots in the Shelf (P1) to secure your equipment in place on the shelf.

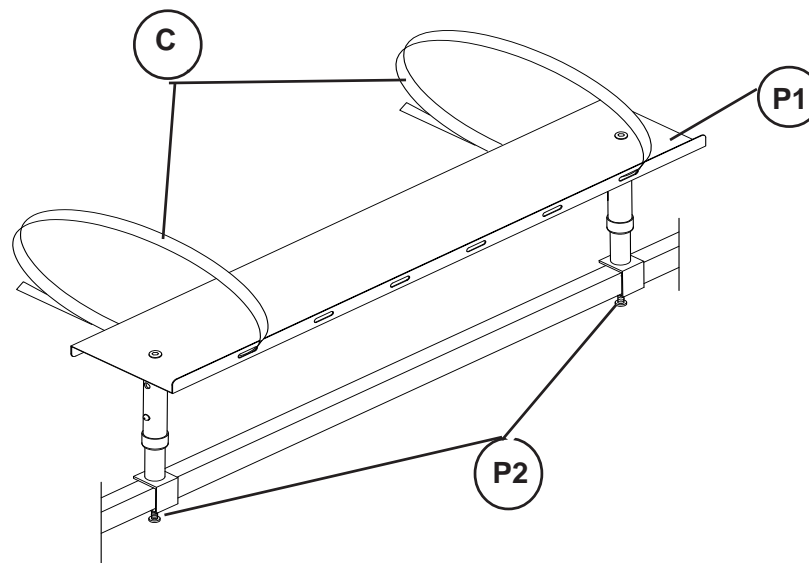

**Illustration # 2**