

#89815

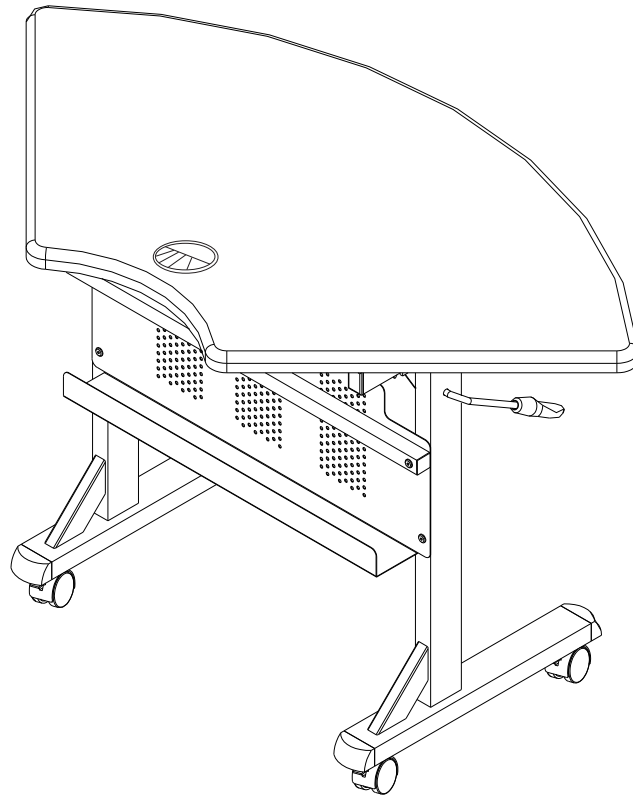









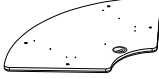
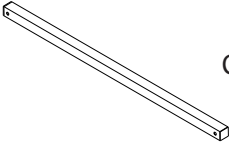
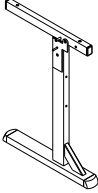

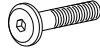
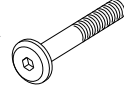

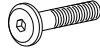
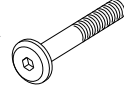

Flipper-1/4 Round

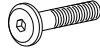
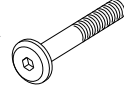

Assembly Instructions

89815

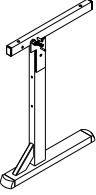
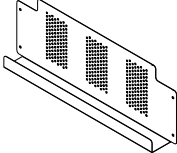
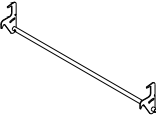
1/4 Round Conference Table

Part	Drawing	Description	Qty	Part	Drawing	Description	Qty																								
P1		Top Platform	1 EA	P8		Crossbrace	1 EA																								
P2		Left Leg	1 EA	<div style="border: 2px solid black; border-radius: 15px; padding: 10px; text-align: center;"> <h3>Hardware List</h3> <table style="width: 100%; border-collapse: collapse;"> <tr> <td style="width: 5%;">A</td> <td style="width: 15%;"></td> <td style="width: 60%;">9/16" Socket Screw</td> <td style="width: 20%;">4 EA</td> </tr> <tr> <td>A1</td> <td></td> <td>1-3/8" Socket Screw</td> <td>2 EA</td> </tr> <tr> <td>B</td> <td></td> <td>1-7/8" Socket Screw</td> <td>4 EA</td> </tr> <tr> <td>D</td> <td></td> <td>2" Locking Caster</td> <td>4 EA</td> </tr> <tr> <td>E</td> <td></td> <td>Allen Wrench</td> <td>1 EA</td> </tr> <tr> <td>F</td> <td></td> <td>Caster Wrench</td> <td>1 EA</td> </tr> </table> </div>				A		9/16" Socket Screw	4 EA	A1		1-3/8" Socket Screw	2 EA	B		1-7/8" Socket Screw	4 EA	D		2" Locking Caster	4 EA	E		Allen Wrench	1 EA	F		Caster Wrench	1 EA
A		9/16" Socket Screw	4 EA																												
A1		1-3/8" Socket Screw	2 EA																												
B		1-7/8" Socket Screw	4 EA																												
D		2" Locking Caster	4 EA																												
E		Allen Wrench	1 EA																												
F		Caster Wrench	1 EA																												
P3		Right Leg (with Spring)	1 EA																												
P4		Metal Stability Panel	1 EA																												
P5		Welded Rod Assembly	1 EA																												
P6		Left Side Handle	1 EA																												
P7		Right Side Handle	1 EA																												

Flipper-1/4 Round Assembly Diagram

READ THROUGH INSTRUCTIONS FROM BEGINNING TO END BEFORE STARTING TO ASSEMBLE UNIT.

- 1.) Identify and Separate all the Parts and Hardware.
- 2.) Slide the Right Side Handle (P7) Through the Right Leg (P-3) and into the Welded Rod (P5) as shown in illustration #1. Rotate Right Side Handle (P7) until holes are aligned (See illustration#1). Secure using 1 Screw (A).
- 3.) Slide the Left Side Handle (P6) Through the Left Leg (P-2) and into the Welded Rod (P5) as shown in illustration #1. Rotate Left Side Handle (P6) until holes are aligned (See illustration #1). Secure using 1 Screw (A).

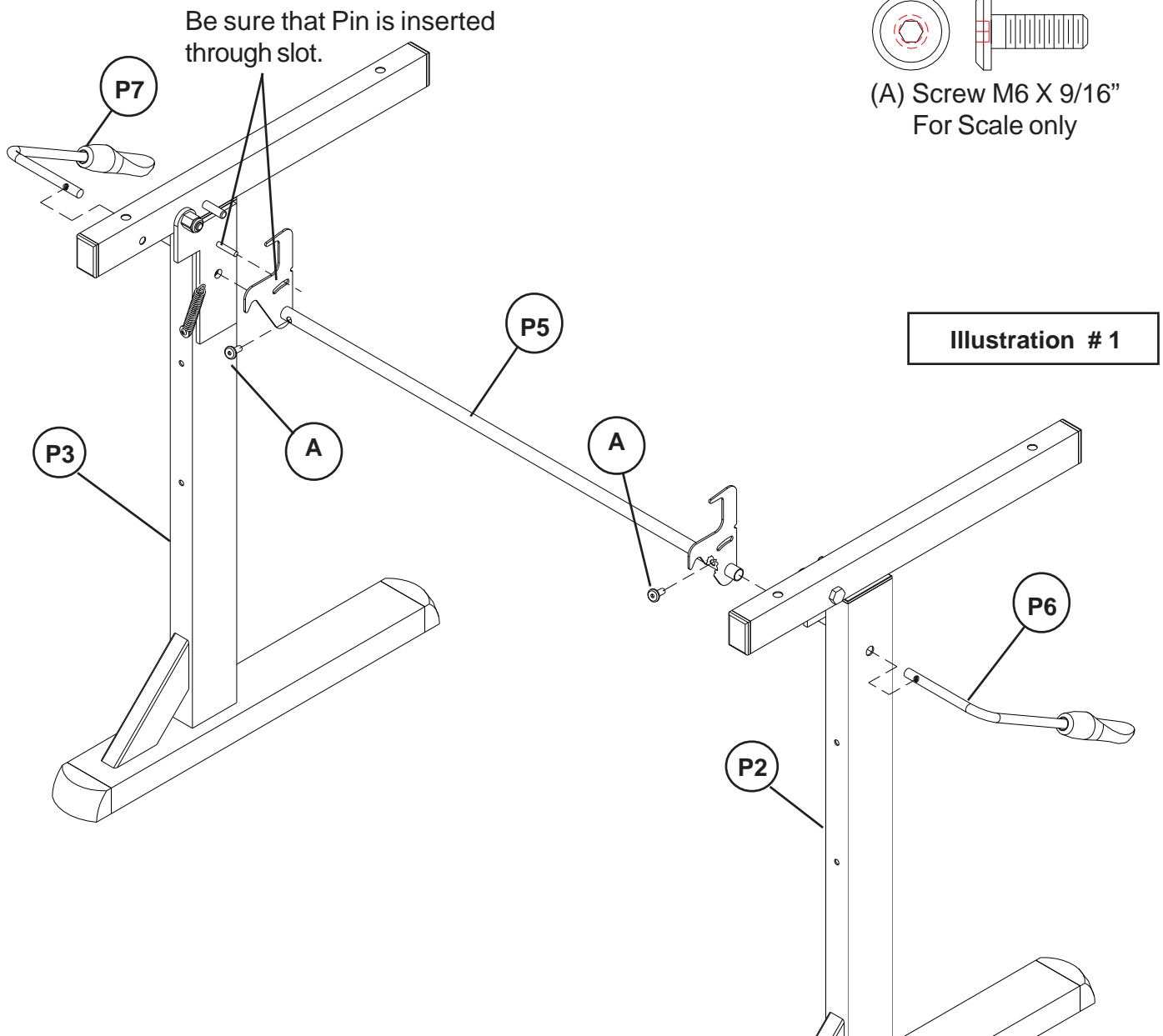
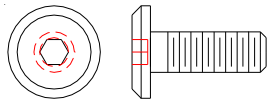

Illustration #2

4.) Attach Metal Stability Panel (P4) and Crossbrace (P-8) to the Right Leg (P-3) and Left Leg (P2) using 2 Screws (A) and 2 Screws (A1) as shown in illustration #2.



(A) Screw M6 X 9/16"
For Scale only



(A1) Screw M6 X 1-3/8"
For Scale only

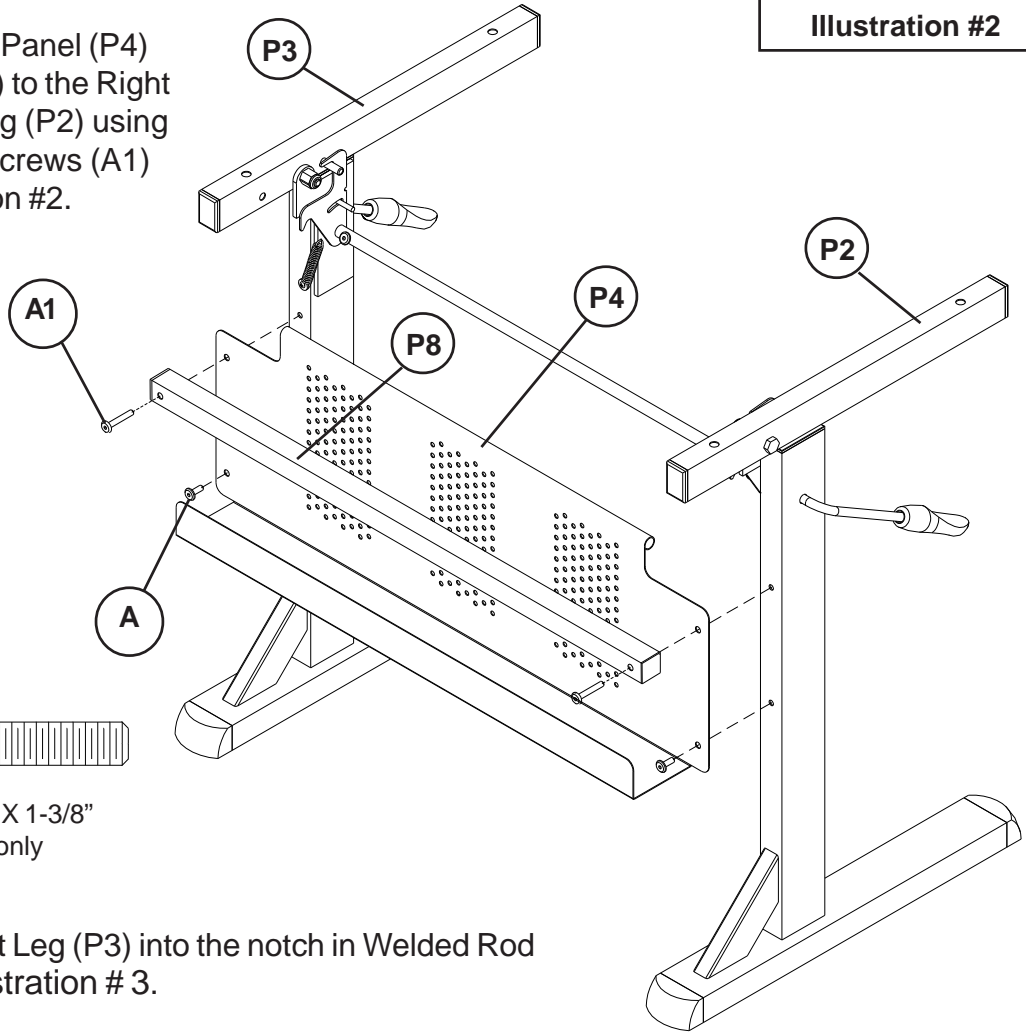

5.) Insert Spring on Right Leg (P3) into the notch in Welded Rod (P5) as shown in illustration # 3.

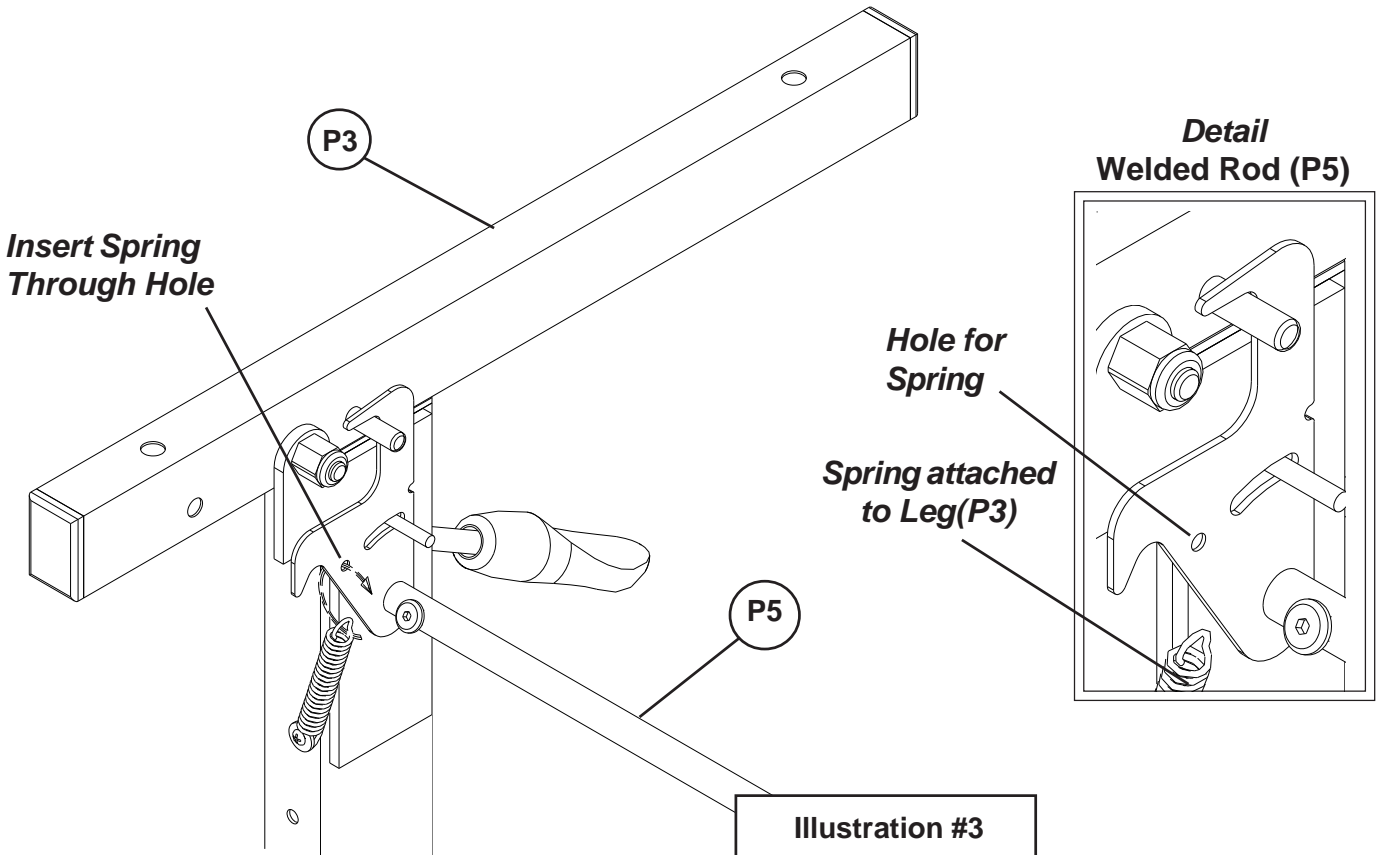

Illustration #3

6.) Place the Top Platform (P1) with the insert nuts facing up. Attach Right Leg (P-3) and Left Leg (P2) using 4 each (B) screws as shown in illustration #4.
(Finger tighten only)

7.) Attach 4 each (D) Locking Casters to the front and back of the Right Leg (P-3) and Left Leg (P2). Tighten Casters using Caster Wrench (F).

(Tighten all screws using Allen Wrench (E).)



(B) Screw M6 X 1-7/8"
For Scale only

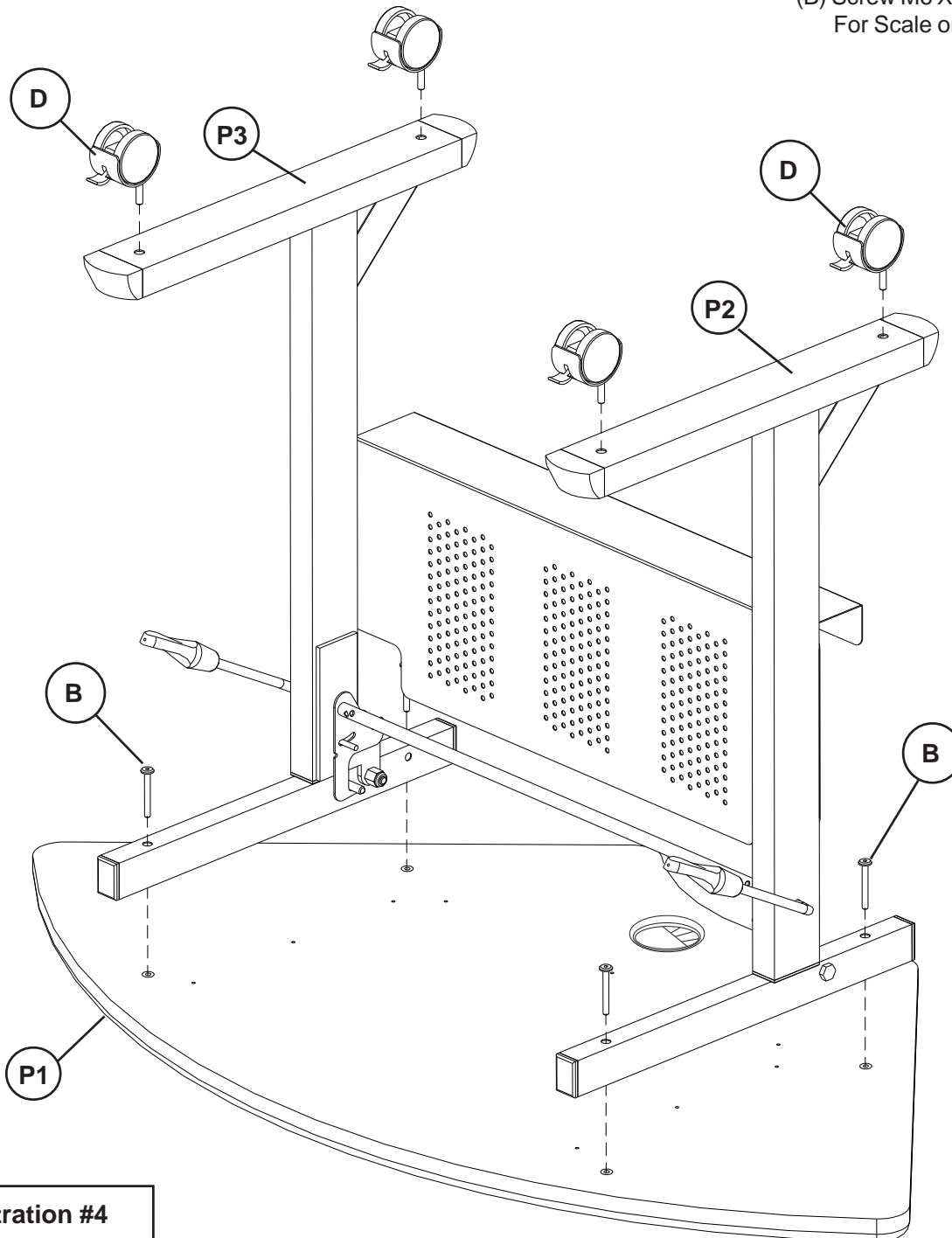
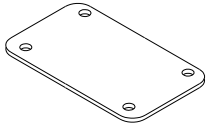
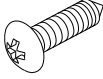

Illustration #4

TT-Connect Plates- Connecting Flipper Tables

Part	Drawing	Description	Qty	Part	Drawing	Description	Qty
P-1		Connecting Plate	1 EA	Hardware List			
A		Wood Screw 1/2"	4 EA				

READ THROUGH INSTRUCTIONS FROM BEGINNING TO END BEFORE STARTING TO ASSEMBLE UNIT.

- 1.) Identify and Separate all the Parts and Hardware.
- 2.) Place 2 Flipper tables end to end, or other configuration as desired. Attach TT- Connecting Plate to both tables using 4 Wood Screws (A) as shown in illustration # 1.

TT-Connect - Flipper Tables Illustration # 1

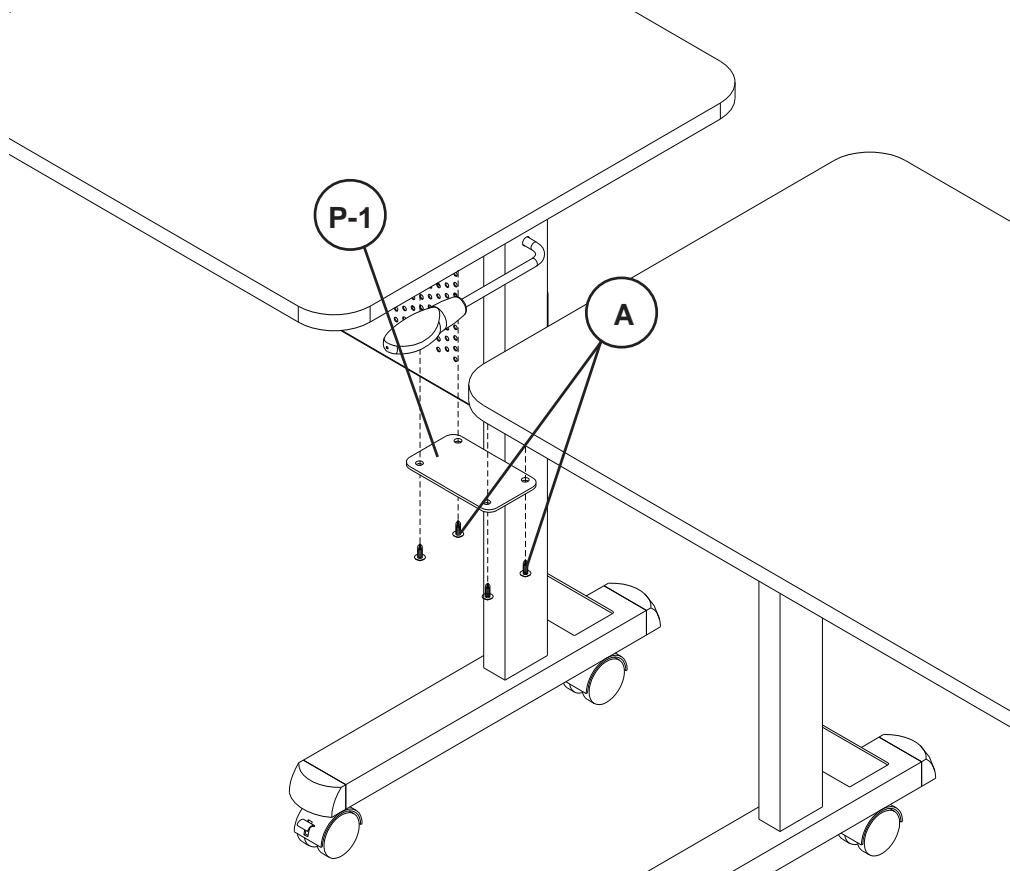

89815 1/4 Round Conference Table

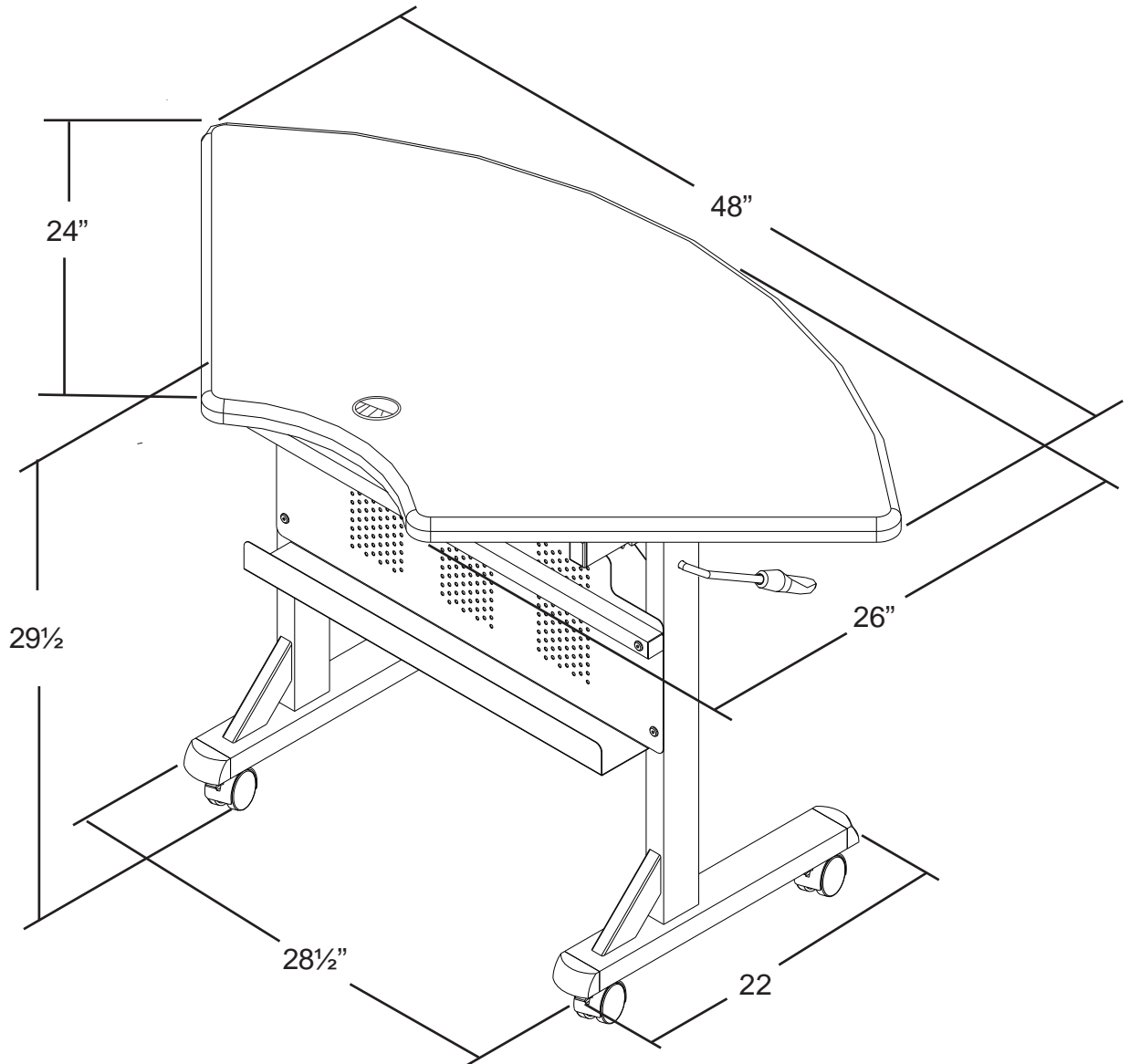

Shipping Information

4.8 Cubic Feet

57 lbs.

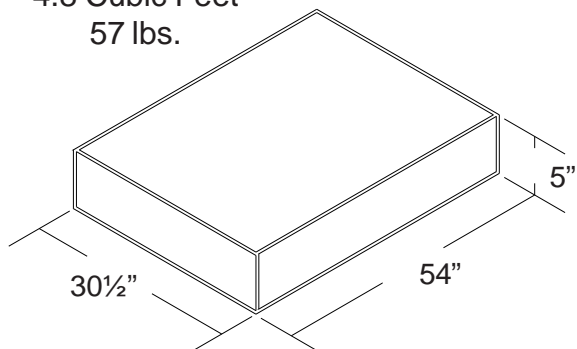

89815-06-30-14