

Motic®

Touchboards

205 Westwood Ave, Long Branch, NJ 07740
Phone: 866-94 BOARDS (26273) / (732)-222-1511
Fax: (732)-222-7088 | E-mail: sales@touchboards.com

PSM-1000

Laser Ready Modular Microscope



PSM-1000 Features

Ergonomic Design

The design of the PSM-1000 encourages the optimal amount of usability without sacrificing comfort.

Ergonomically constructed for all major forms of image adjustment to be accessible within the span of your hand.

- ① Diopter
- ② Aperture Diaphragm
- ③ Beam Splitter
- ④ Changeover Turret
- ⑤ Analyser/Polariser



Laser Work¹

The PSM-1000 is standard equipped for laser work covering the spectrums ranging from 355nm [UV] to 532nm [Green] to 1064nm [IR]. Conveniently positioned, the beam splitter switches the PSM-1000 from a visual unit [50:50 split between binocular eyetubes and trinocular port] to a laser work unit. Through the specially coated optical system, the PSM-1000 produces an infrared [1064nm] efficiency of 82%².

Central to the PSM-1000's high laser efficiency and functionality is the changeover turret, which consists of three specialised lenses. 1XUV/VIS for the spectrum of 355nm - 532nm; 1XIR/VIS for the 532nm - 1064nm spectrum; and a 2XVIS magnifier to achieve optimal magnification of 2000X [with 100X objective]. The turret base design provides the convenience of rapid switching between spectrums to complete the task.

With safety in mind, the PSM-1000 includes a laser safety pin to shut down the laser to avoid accidents, as well as shims to securely mount and hold the laser provider's safety filter.



Focusing Block

Rated for load weights up to 45lbs., image focal planes can be adjusted at 1mm resolutions within the total 50mm stroke. Reversible for space conscious applications in addition to extra mounting slots for placement on other manufacturers' microscopes, adaptability is the key with the PSM-1000 focusing block.



Adjustable Nosepiece

Forward facing and equipped for four M26 x 1/36" (0.706) type objectives, the PSM-1000's nosepiece is dovetail mounted for moulding to different types of research and usage. Complementing the versatility of the nosepiece is Motic's hassle-free parcentration. With the standard centering keys [pictured on the right], parcentration of individual ports can be achieved while remaining focused on the sample.



1. Motic assumes no responsibility whatsoever for the performance and/or safety of the laser system used with the Motic PSM-1000 microscope.

See laser manufacturer for proper operation.

2. Tested by New Wave Research [Fremont, California, USA]. For detailed information, contact your local Motic supplier.

SPECIFICATION OF LASER READY MODULAR MICROSCOPE PSM-1000

Purpose	Quick and Surface Inspection, Quality Control, Laser Repairs and Device Research
Observation Tube	Widefield trinocular tube, 50 : 50 and 0 : 100 optical observation angle Siedentopf infinity, 55 - 70mm Interpupillary distance
Eyepiece	Widefield High-eyepoint, Infinity Corrected 10x/24mm Accepts Ø25mm reticules
Turret	3-lens changeover turret 1x IR tube lens, 1x UV tube lens, 2x Visible magnifier
Laser Work	Pull out beam splitter, Laser Safety Pin, Shims
Wavelengths Coverage*	355nm [UV] to 532nm [Green] to 1064nm [IR]
Nosepiece	Quadruple, outward-facing Spring-loaded, Adjustable parcentration Dovetail mounted for easy removal
Objectives (Optional)	Extra and Ultra Long Working Distance Plan Apochromat objectives Range of magnifications from 2x to 100x, M26 x 1/36" (0.706) thread size Adjustable parfocality available
Microscope Magnification Range	20x - 2000x
Aperture Diaphragm	Adjustable field of depth and contrast, Adjustment range : Ø0.8 - Ø6mm
Focusing Block	50mm Stroke Coaxial operation system Coarse 4mm per rotation Fine 0.1mm per rotation 1 mm resolution 45 lbs. Mountable weight
Illumination	Reflective illumination for brightfield
Optional Contrast	Polarisation Spectrum range: 400nm - 700nm Adjustable Polariser available
Fiber Optic Illumination (Optional)	Switchable power input [115V - 220V] 150W / 21V output 1,600,000 lux Colour Temperature Range: 500K - 3700K Flexible light guide with Ø15mm distal end
Weight [Head only]	16lbs.
Dimensions	372mm (h) x 218mm (w) x 333mm (d) - with focusing block

* Designed around the New Wave Research line of lasers

PSM-1000 DIMENSIONS

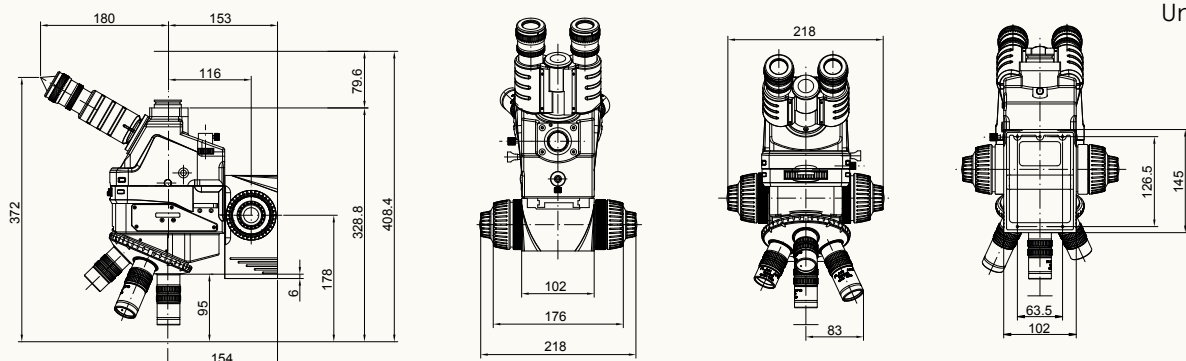

PSM-1000 Accessories

Eyepieces

Employing adjustable, high-eyepoint, Widefield 10x/24mm eyepieces, the PSM-1000 ensures the optimal amount of visual inspection. Each eyepiece can have diopter adjustments of $\pm 5^\circ$. An additional versatility is the acceptance of reticules [Ø25mm].

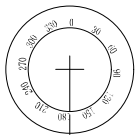

Reticule
360° : 10°
SG060314

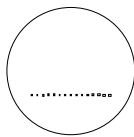

Reticule
14mm : 0.2mm
SG060320

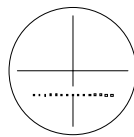

Reticule
14mm : 0.1mm
SG060315

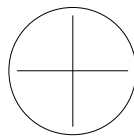

Plain Cross
Hair Reticule
SG060342



WF15x and 20x eyepieces

Plan Apochromat Objectives

Motic's Plan Apochromat objectives provide the working distances at the numerical aperture values needed. Covering magnification ranges from 2x to 100x, the Plan Apochromat objectives are also available with the unique option of parfocality adjustment. Furthermore, Motic also provides you Plan Apo NIR 20X and 50X to fit a wide range of laser applications, such as laser-cutting fine-films of semiconductors and of liquid crystal substrates and much more. Designed to focus within the depth of focus, even when the laser wavelength used changes from the visible radiation (wavelength 532nm) to the near-infrared radiation range (wavelength 1064nm). The mounting thread is M26 x 1/36" (0.706) for integration to existing systems. Please refer to Motic's Plan Apochromat catalogue for further information.



Digitalisation

Utilising a Moticam digital application camera with the corresponding optional camera adapters, the PSM-1000 becomes an analysing, documentation, teaching, and training system.



0.3x
Camera Adapter
[1/3" chip sensors]



0.4x
Camera Adapter
[1/2" chip sensors]



0.5x
Camera Adapter
[2/3" chip sensors]



1x
Camera Adapter
[1" and 2/3" chip sensors]



PSM-1000 with Moticam 3000 attached

Tilting Head

With 300mm wafer fabrications coming online in addition to ergonomic requests, the PSM-1000 is offered with an optional tilting head format. The tilting head has an observation angle adjustment of 3° to 30° as well as being laser ready. A further beneficial option is the ability to retrofit existing PSM-1000s with a tilting head without the requirement of a factory return. Schematic diagram is located below.



Stand/Stage

Equipping the PSM-1000 for simple and quick inspection, and/or laser work is achieved by opting for the stand/stage. The compact footprint allows for installation into space conscious work environments. The mechanical stage has a travel range of 75mm [X-axis] and 50mm [Y-axis].

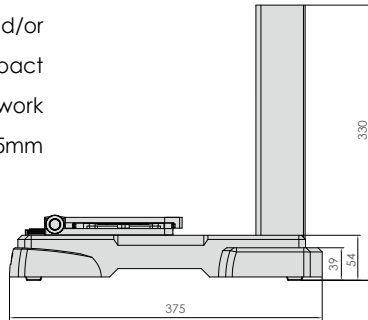

PSM-1000 Tilting Head Dimensions

Unit : mm

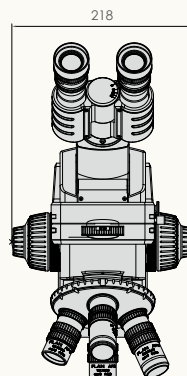
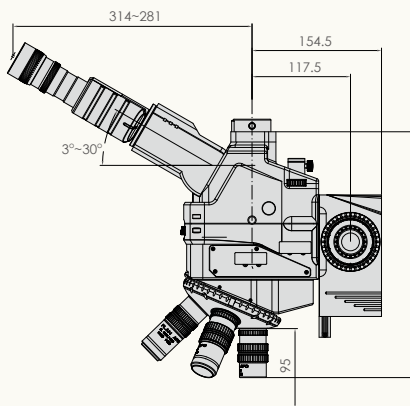

PSM-1000 Applications

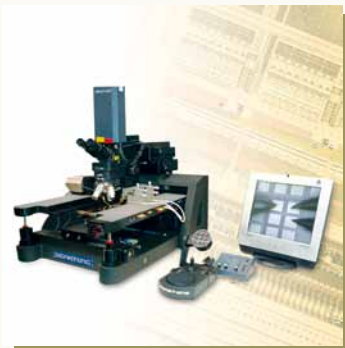

Failure analysis of wafers

Measuring microscope applications with addition of reticules



Digital documentation, analysis, and/or device testing

Modular Surface Inspection utilising parcentering nosepiece and parfocality adjustable objectives



Beam Splitter allows for Emission microscopy setup

Medical Research Applications with long working distance Plan Achromat objectives

Polarisation with universal adaptable cassette sliders for device research



Engineer station for quick inspection



FPD laser repairs and laser machining

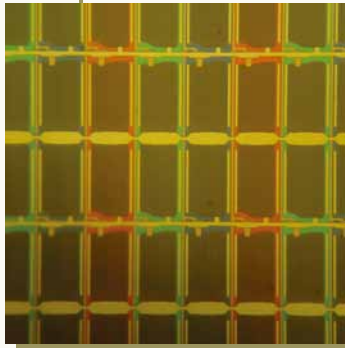

High magnification inspection

System Diagram

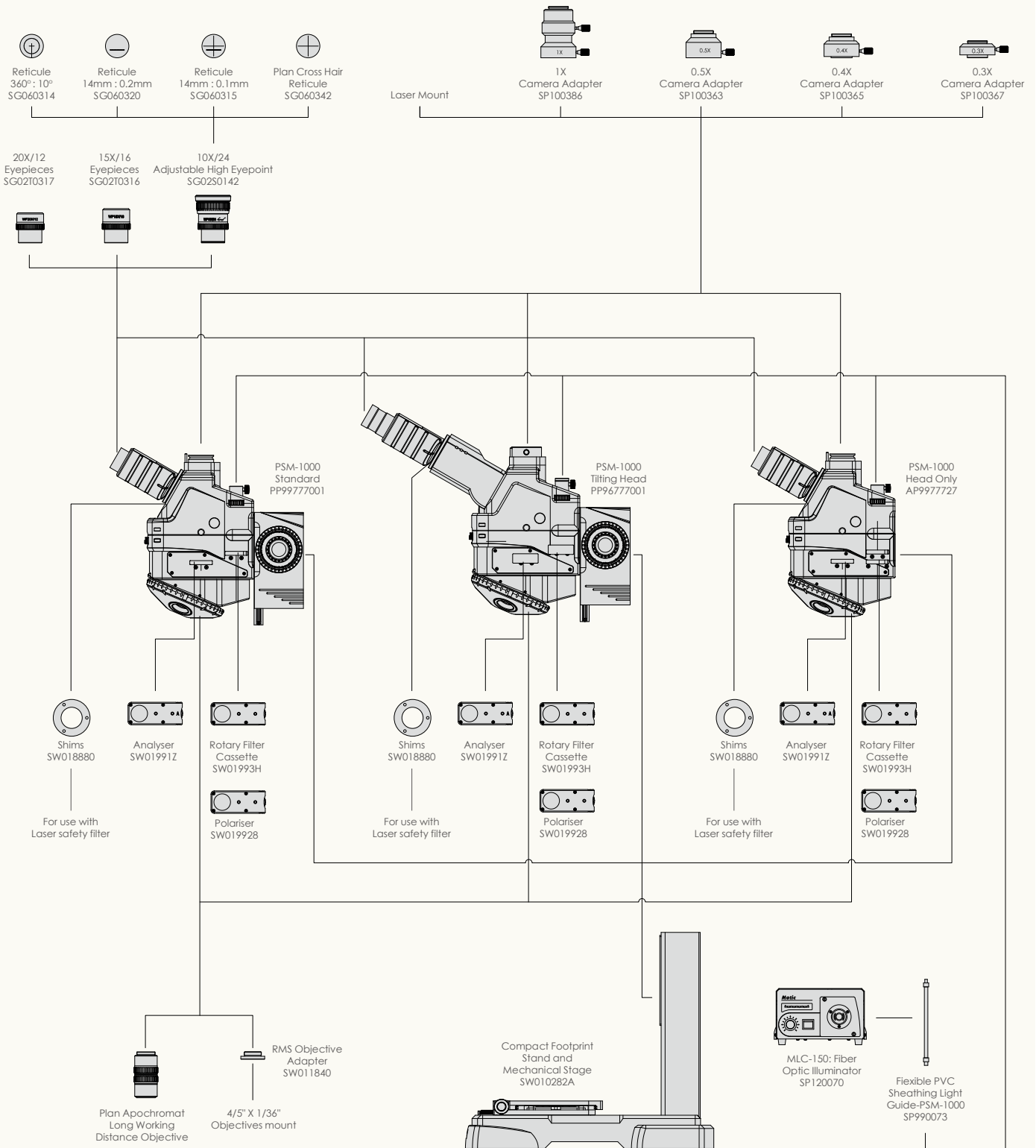

Motic[®] Microscopes

Motic[®]

Touchboards

205 Westwood Ave, Long Branch, NJ 07740
Phone: 866-94 BOARDS (26273) / (732)-222-1511
Fax: (732)-222-7088 | E-mail: sales@touchboards.com

CE



Motic Incorporation Ltd. Copyright © 2002-2011. All Rights Reserved
Design Change: The manufacturer reserves the right to make changes in instrument design in accordance with scientific and mechanical progress, without notice and without obligation.

Code: 1300901301671
Updated: 2011.01