

Technical Specifications

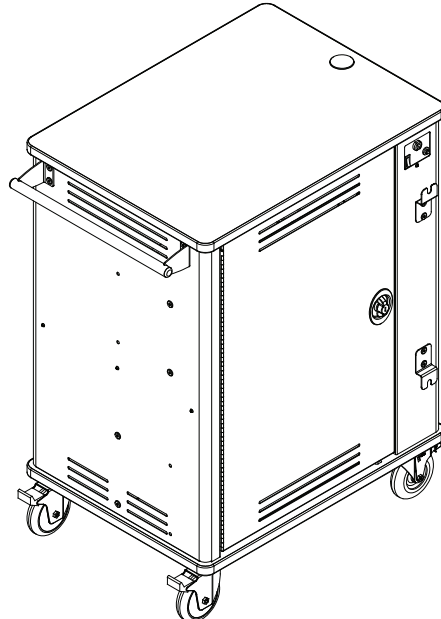

205 Westwood Ave, Long Branch, NJ 07740
Phone: 866-94 BOARDS (26273) / (732)-222-1511
Fax: (732)-222-7088 | E-mail: sales@touchboards.com

available configurations:	
55480DW	base cart
55481DW	base cart + 8 wire dividers (for 8 units)
55482DW	base cart + 16 wire dividers (for 16 units)
55483DW	base cart + 24 wire dividers (for 24 units)
55484DW	base cart + 32 wire dividers (for 32 units)

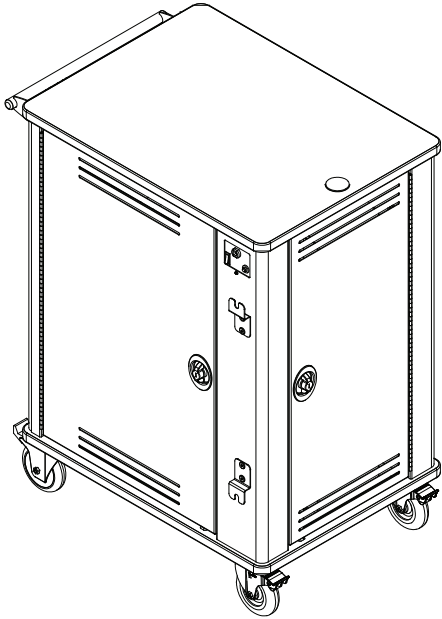

How can you be sure that a specific mobile technology is what is best for your students' ultimate development? Some students progress more rapidly with smart phones, others with tablets, and yet others prefer the larger format of a laptop. Moreover, recent advancements with student response clickers have greatly increased student involvement in the classroom. It would be great to expand your curriculum to include all of these technologies, but how could you keep the different devices organized, and how would you make sure each mobile technology is ready for use when your class needs them? The eVolve is set up as a modular system with each module set up to specifically support laptops, tablets, smart phones, or netbooks. Use any combination of available technologies, charged and ready to distribute to students. Be able to develop your students and your curriculum with the best available technology. Everything is in one place. Ready when you need it. Progress with the Spectrum eVolve Multi-Tech Cart.

Features and Benefits

- Durable powder coated steel chassis
- Two storage shelves/bays support up to 16 full-size laptop computers, or 32 tablets or netbooks
- Coated wire dividers protect devices from damage and can be installed to provide storage for tablets, laptops, netbooks, or a combination of all three
- Locking third door electrical compartment isolates and separates electrical line voltage from students
- Two 16-outlet power units with externally accessible on/off switches and reset buttons
- Overhead cord management bars keep charge cords organized and routed to each storage slot
- One standard handle provides control and mobility
- Padded shelves protect devices from damage
- Ventilated doors provide "chimney effect" airflow keeping equipment cool
- Cable grommets keep wires and cords organized
- External cord wraps keep power cords together
- Electrical system consists of UL-listed components
- Double-bolt, keyed locking doors provide security and easy-access
- Scratch and impact-resistant 1 1/8" high-pressure laminate worksurface
- Four 5" balloon wheels (2 swivel directional locking) roll easily and quietly on uneven surfaces
- Additional wire dividers are available to provide future expansion or reconfiguration
- Optional power cord organizer manages power cords and transformers
- Optional small device foam module/organizer provides storage for up to 16 small devices (like smart phones)
- Optional power supply tray
- Warranted to be free of all defects in materials and workmanship for 10 years

DW - 5" balloon wheels
(2 rigid, 2 swivel directional locking)

Options & Accessories
Page 10

Color Options

Standard laminate / color combinations

White Fiesta / Cool White (WFCW)

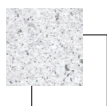

Standard color combination refers to the quickest deliverable product color combination. Custom laminates and color combinations are available-additional lead-times and up-charges may apply. Call 1-800-235-1262 for further information.

Construction

- The worksurface and base panel is constructed from 1 $\frac{1}{16}$ " thick NAUF (no added urea formaldehyde) composite board with .030 high-pressure laminate on one face, and a balancing phenolic backer on the opposing face
- Metal components consist of 16-gauge steel
- Worksurface edges are covered with 3mm vinyl
- All metal components are finished with a scratch-resistant powder coat epoxy
- Each eVolve Multi-Tech Cart is factory-assembled with casters, packaged, and shipped on its own skid

Specifications

Internal area	23"W x 21"D x 35 $\frac{1}{2}$ "H - device storage compartment 15 $\frac{1}{2}$ "W x 4 $\frac{15}{16}$ "D x 35 $\frac{3}{8}$ "H - electrical compartment																					
Total device capacities (maximum per cart)	up to 16 full-size laptop/notebook computers up to 32 netbooks up to 32 tablets																					
Device storage shelves/bays	2																					
Wire divider slot sizes	<table border="1"> <thead> <tr> <th>Width</th> <th>Depth</th> <th>Height</th> <th>Max units per storage shelf</th> <th></th> </tr> </thead> <tbody> <tr> <td>2$\frac{5}{8}$"</td> <td>16$\frac{7}{8}$"</td> <td>15$\frac{1}{16}$"</td> <td>8</td> <td>Full-size laptop</td> </tr> <tr> <td>2"</td> <td>10$\frac{5}{16}$"</td> <td>15$\frac{1}{16}$"</td> <td>20 (10 per side)</td> <td>Netbook</td> </tr> <tr> <td>1$\frac{1}{4}$"</td> <td>10$\frac{5}{16}$"</td> <td>15$\frac{1}{16}$"</td> <td>32 (16 per side)</td> <td>Tablet (iPad®)</td> </tr> </tbody> </table>		Width	Depth	Height	Max units per storage shelf		2 $\frac{5}{8}$ "	16 $\frac{7}{8}$ "	15 $\frac{1}{16}$ "	8	Full-size laptop	2"	10 $\frac{5}{16}$ "	15 $\frac{1}{16}$ "	20 (10 per side)	Netbook	1 $\frac{1}{4}$ "	10 $\frac{5}{16}$ "	15 $\frac{1}{16}$ "	32 (16 per side)	Tablet (iPad®)
Width	Depth	Height	Max units per storage shelf																			
2 $\frac{5}{8}$ "	16 $\frac{7}{8}$ "	15 $\frac{1}{16}$ "	8	Full-size laptop																		
2"	10 $\frac{5}{16}$ "	15 $\frac{1}{16}$ "	20 (10 per side)	Netbook																		
1 $\frac{1}{4}$ "	10 $\frac{5}{16}$ "	15 $\frac{1}{16}$ "	32 (16 per side)	Tablet (iPad®)																		
Electrical	<p>The eVolve cart has two 16-outlet (32 total available outlets) 125V power units, each with a 15-amp breaker, on/off switch, and a 15' nominal 14 AWG 3-wire power cord. A locking third door compartment isolates and separates electrical line voltage from students. UL listed components.</p> <p><i>Note: The eVolve Multi-Tech Cart features two separate 16-outlet charging circuits on separate cords. The customer should be aware of the amp draw of the devices used with this cart-especially when maxing out the storage capacity with laptops or netbooks. Amp draw can vary considerably between different computing devices. Exceeding 15 amps per 16-outlet power unit will trip the circuit breaker, making a separate wall circuit for each power strip necessary in some extreme circumstances. Please consult the owners manual of your specific device for further information.</i></p>																					
5" balloon wheels	weight capacity 325 lbs each	Four 5" balloon wheels (2 rigid, 2 directional swivel locking)																				
Power cord organizer (optional accessory)	shelf dims: 7 $\frac{7}{8}$ "W x 2 $\frac{3}{8}$ "D x 4"H	3 shelves each, max two organizers per cart																				
Small device slotted foam module (optional accessory)	space available per slot: 1 $\frac{1}{2}$ "W x 5 $\frac{1}{2}$ "D x 15 $\frac{1}{16}$ "H	16 slots available																				
Power supply tray (optional accessory)	21 $\frac{15}{16}$ "W x 3 $\frac{15}{16}$ "D x 1 $\frac{15}{16}$ "H																					
Unit weight (nominal)	221 lbs																					
Shipping weight (nominal)	271 lbs																					
Meets or exceeds applicable ANSI-BIFMA test standards																						

Specifications subject to change without notice

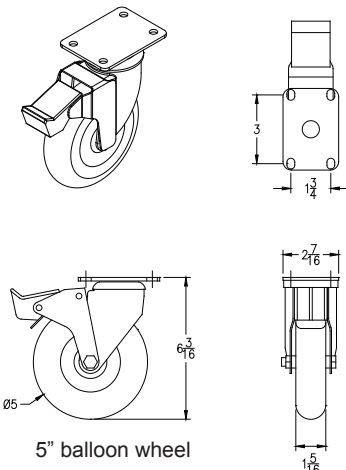

Note: Two swivel directional locking 5" balloon wheels can be rotated and locked at 180° intervals to be rigid, or unlocked to be swivel, and allow the unit to be extremely mobile for easy transport between classrooms.

Note: Wire dividers can be positioned to accommodate tablets, laptops, netbooks, or a combination of all three.

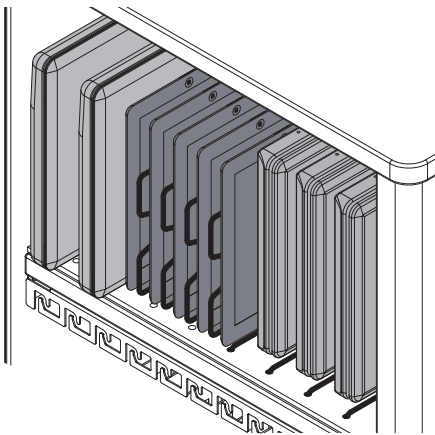

eVolve Multi-Tech Cart

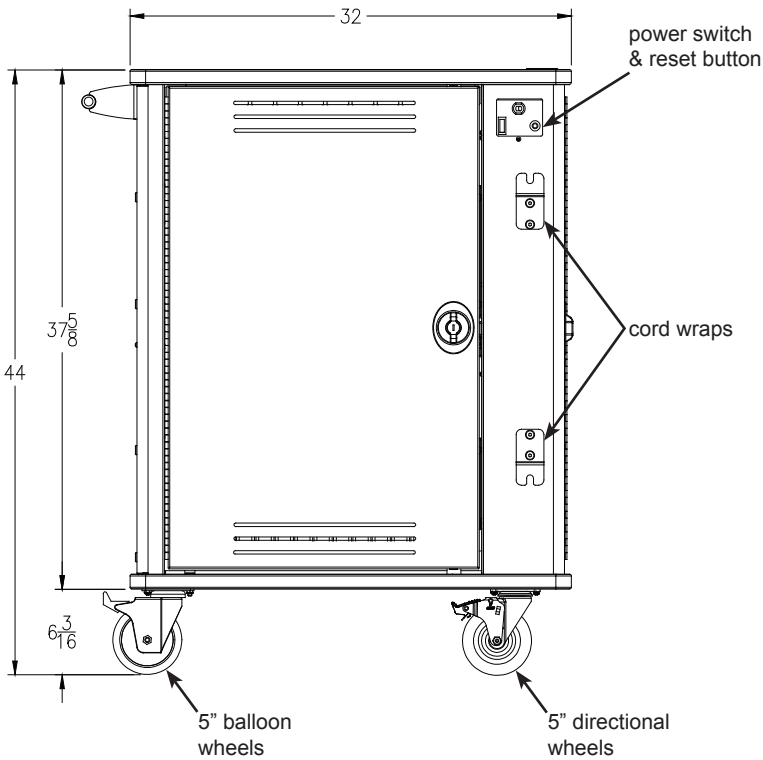
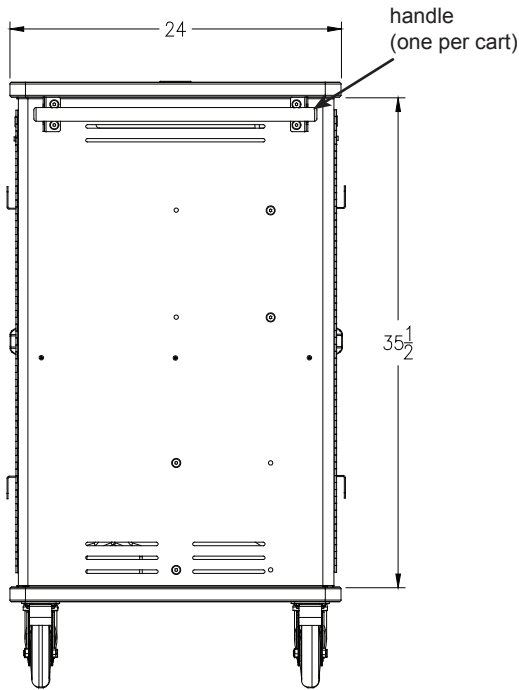
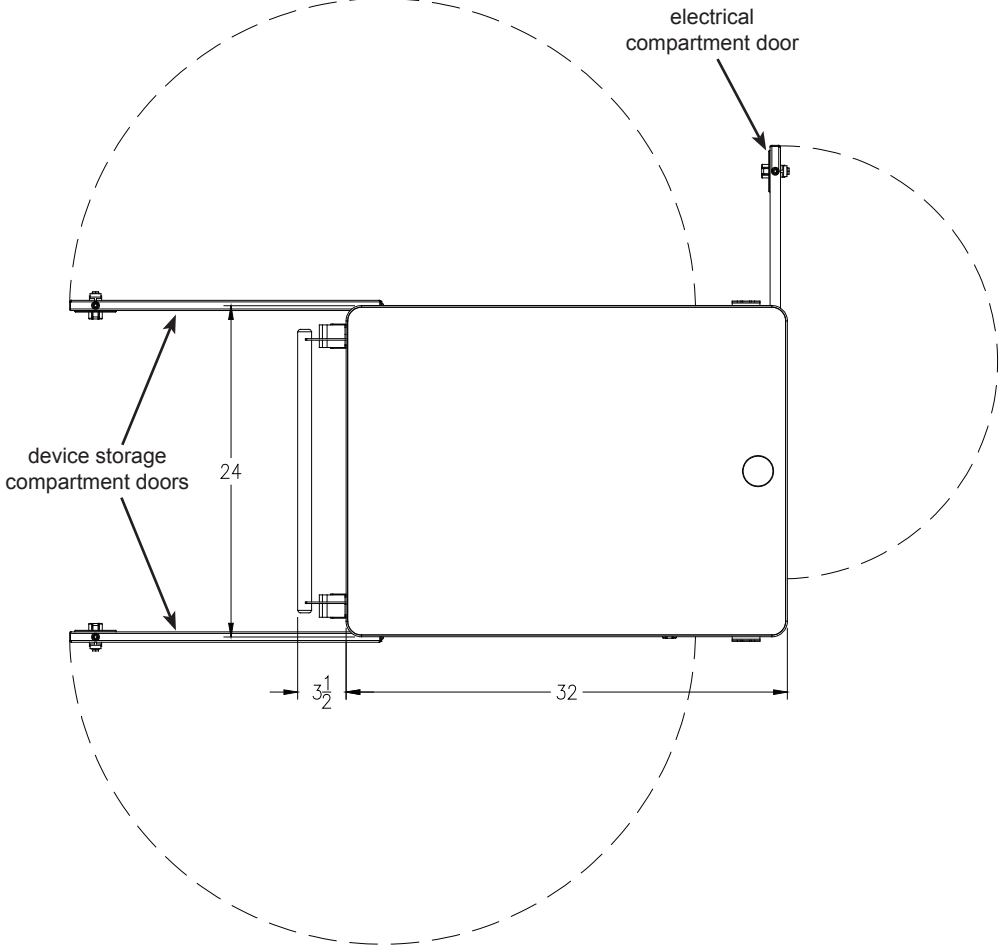
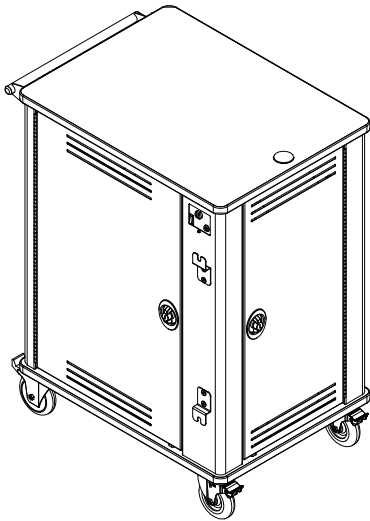

Full-Size Laptops
 up to 8 full-size laptops per shelf
 8 wire dividers configured for full-size laptops
 with divider panel located in full-depth position

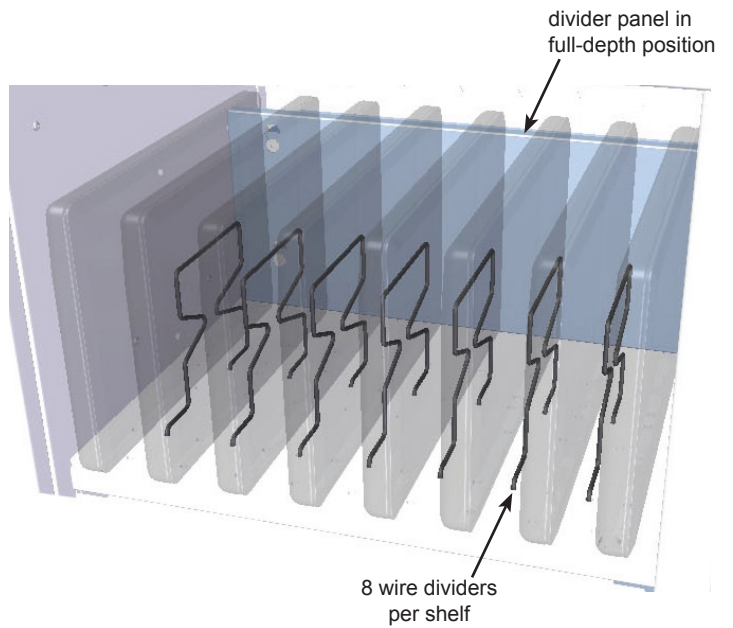
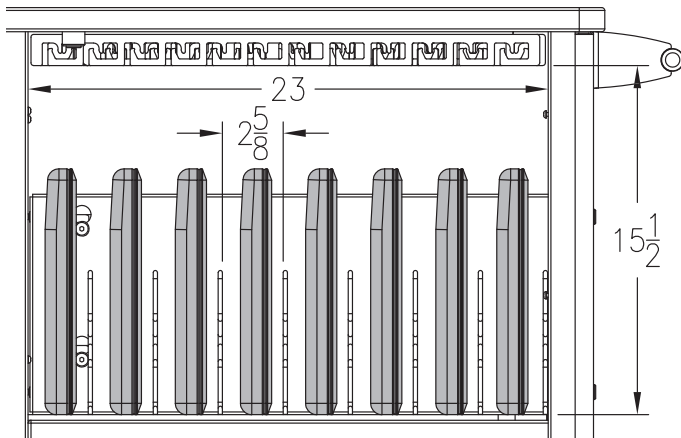

Netbooks
 up to 20 netbooks per shelf (10 per side)
 10 wire dividers configured for netbooks
 with divider panel located in mid position

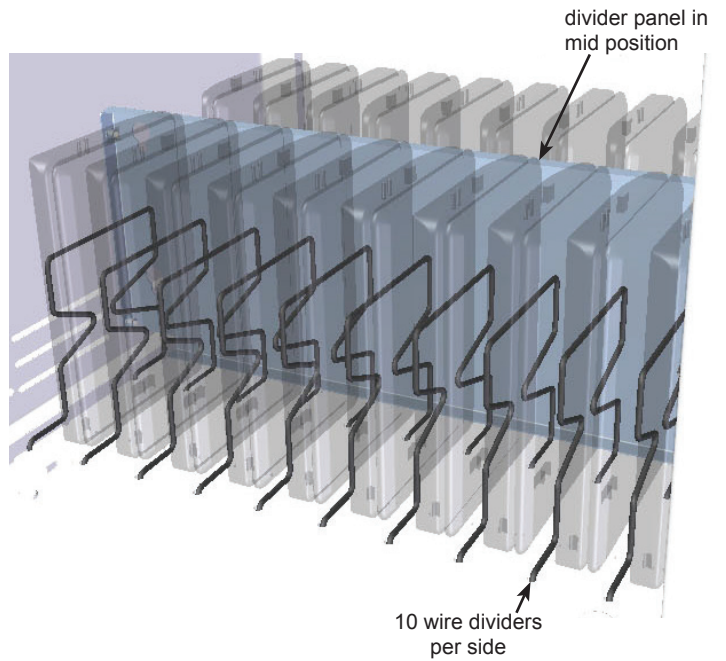
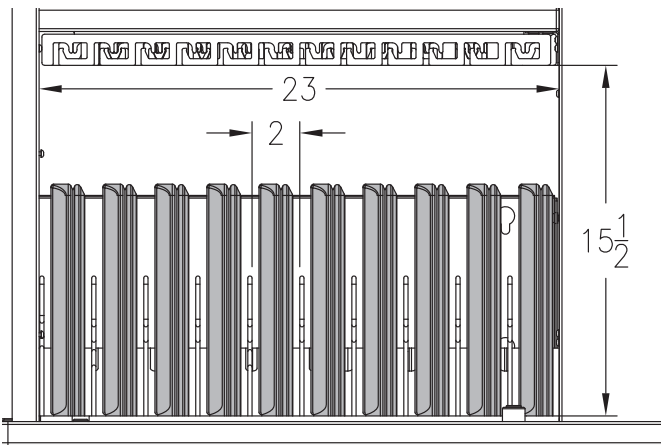

Tablets
 up to 32 tablets per shelf (16 per side)
 16 wire dividers configured for tablets (iPads®
 shown) with divider panel located in mid position

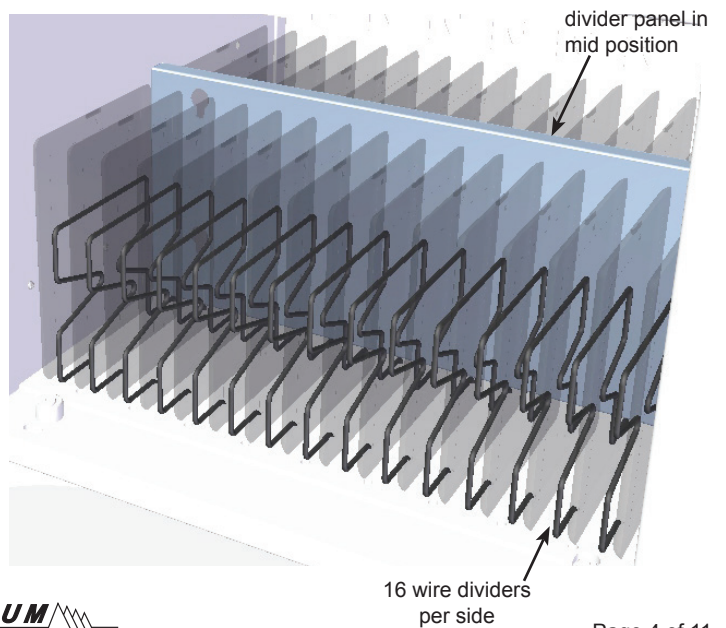
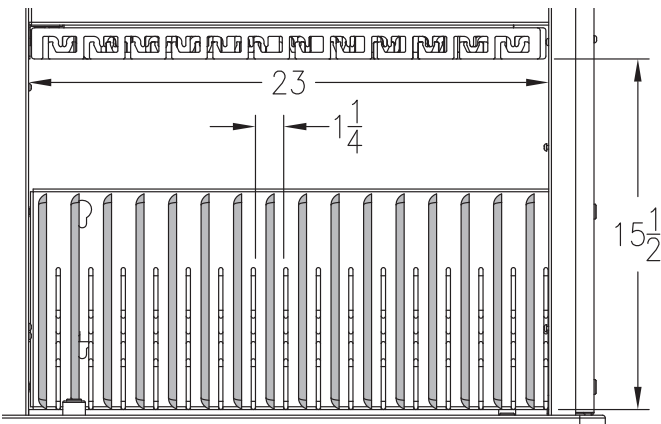

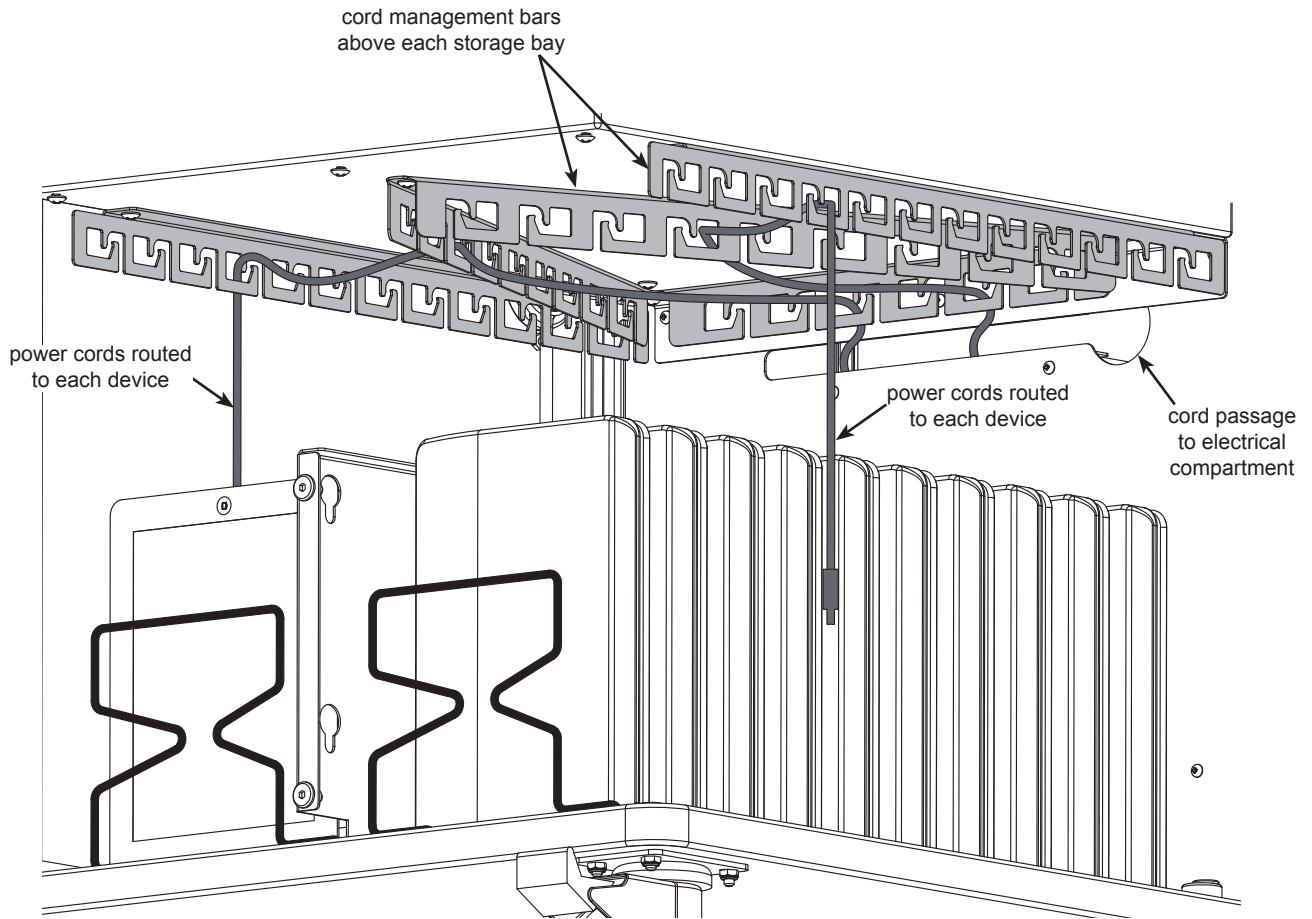

Top view of cord management bars and power cord routing from electrical compartment to computers

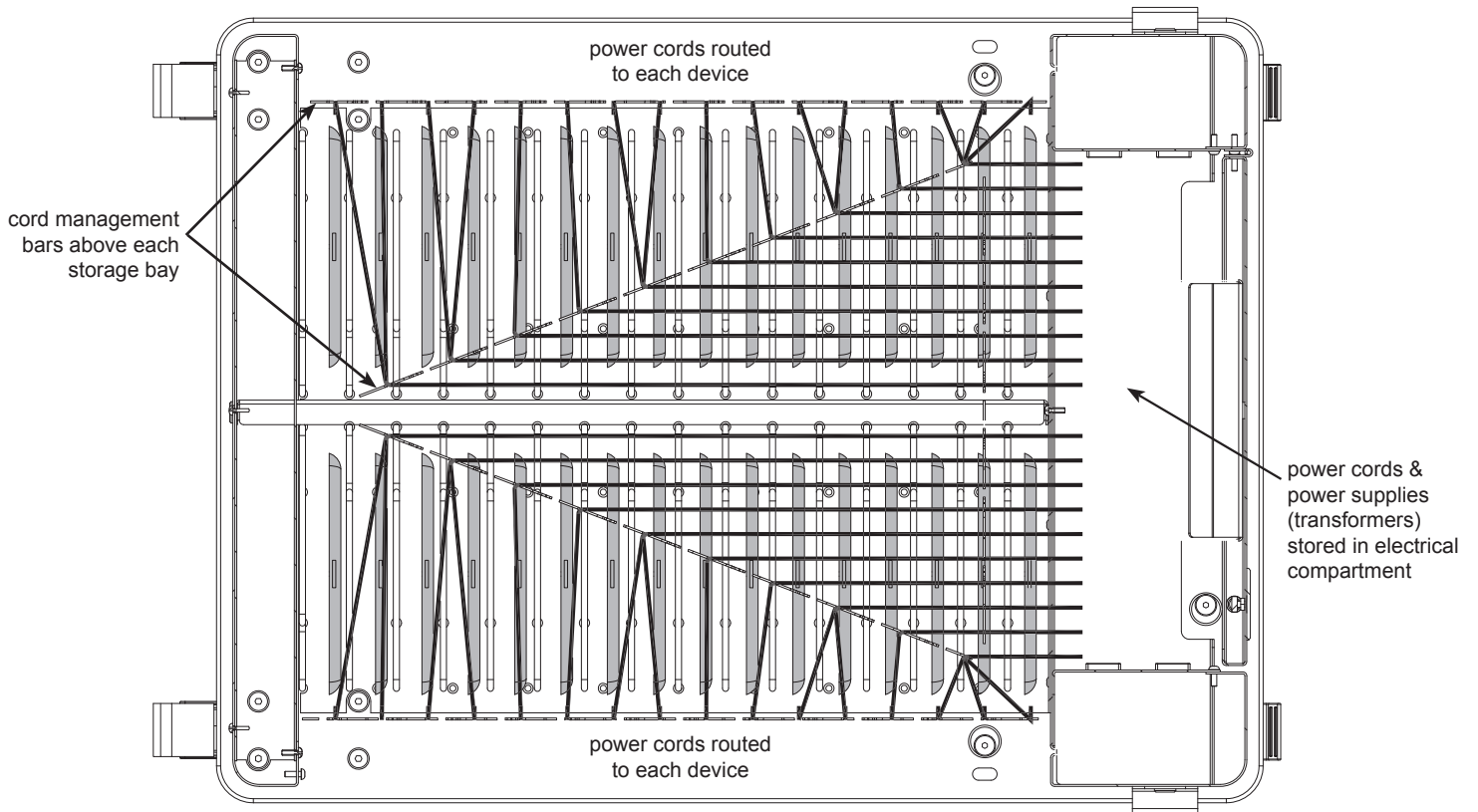

section view of device
storage section

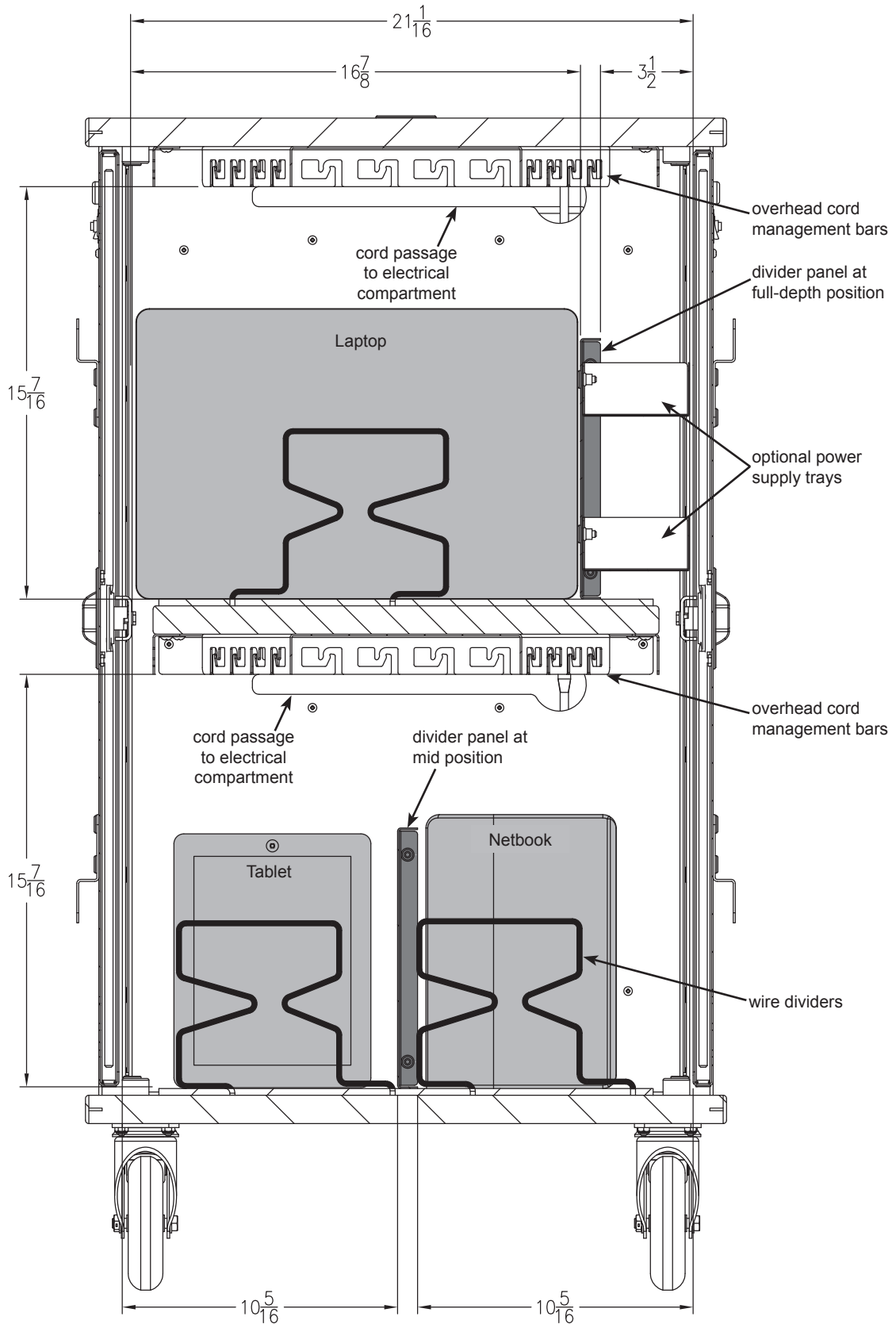

electrical compartment
(shown without door)

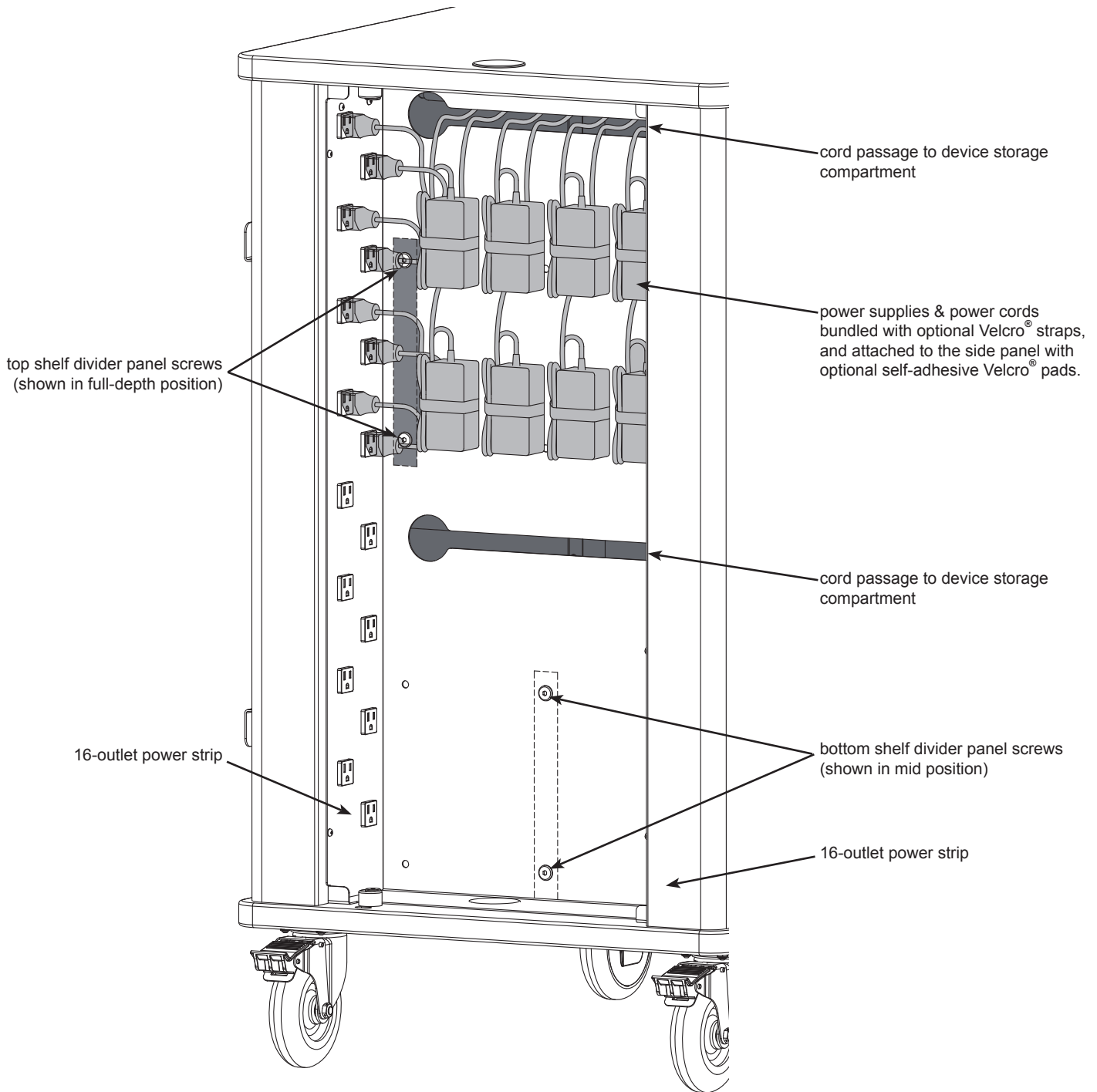

CAUTION

The eVolve Multi-Tech Cart features two separate 16-outlet charging circuits on separate cords. The customer should be aware of the amp draw of the devices used with this cart—especially when maxing out the storage capacity with laptops or netbooks. Amp draw can vary considerably between different computing devices. Exceeding 15 amps per 16-outlet power unit will trip the circuit breaker. Please consult the owners manual of your specific computer for further information.

outlet spacing on each
16-outlet power strip

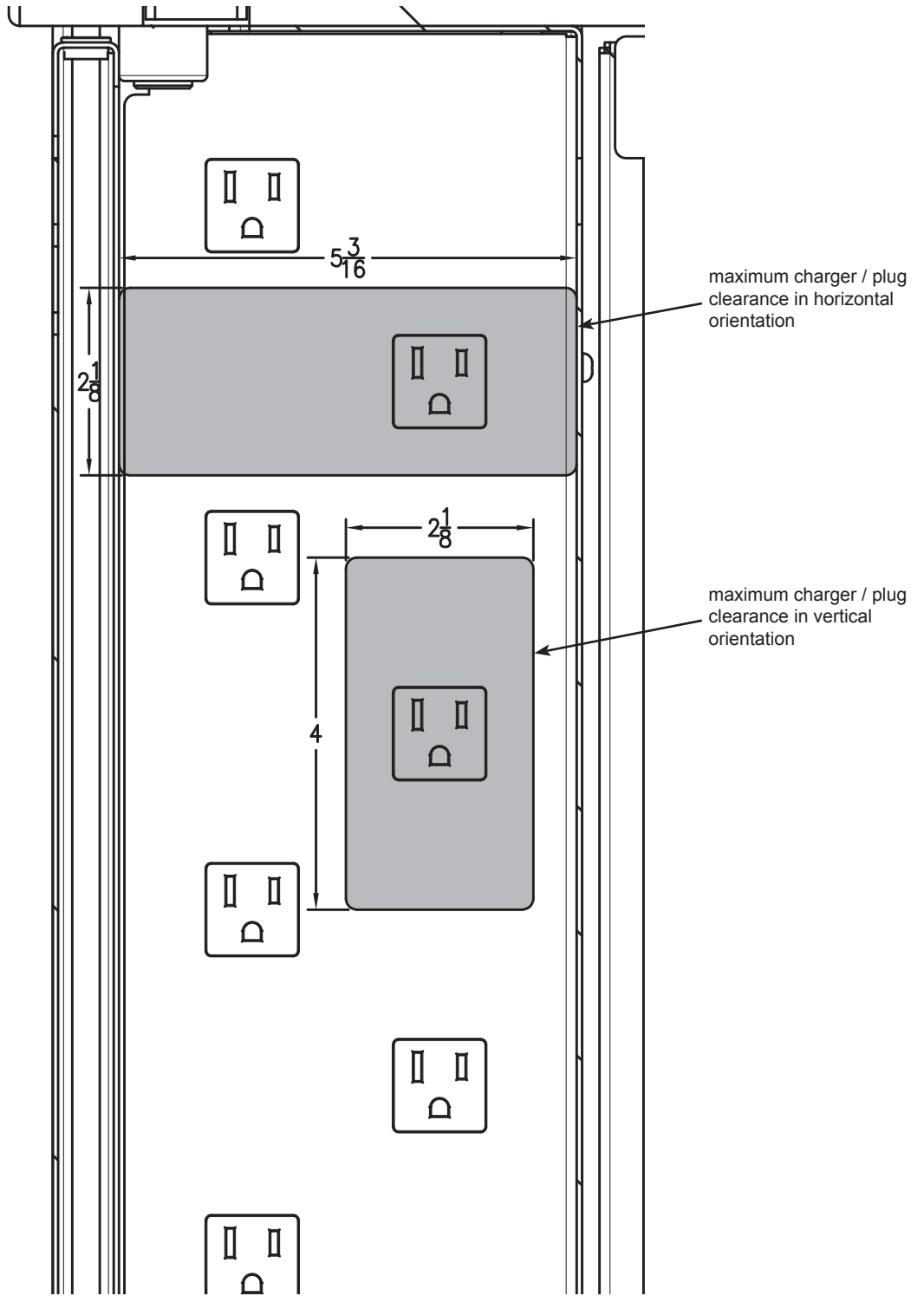

electrical compartment with two optional power cord organizers (shown without door)

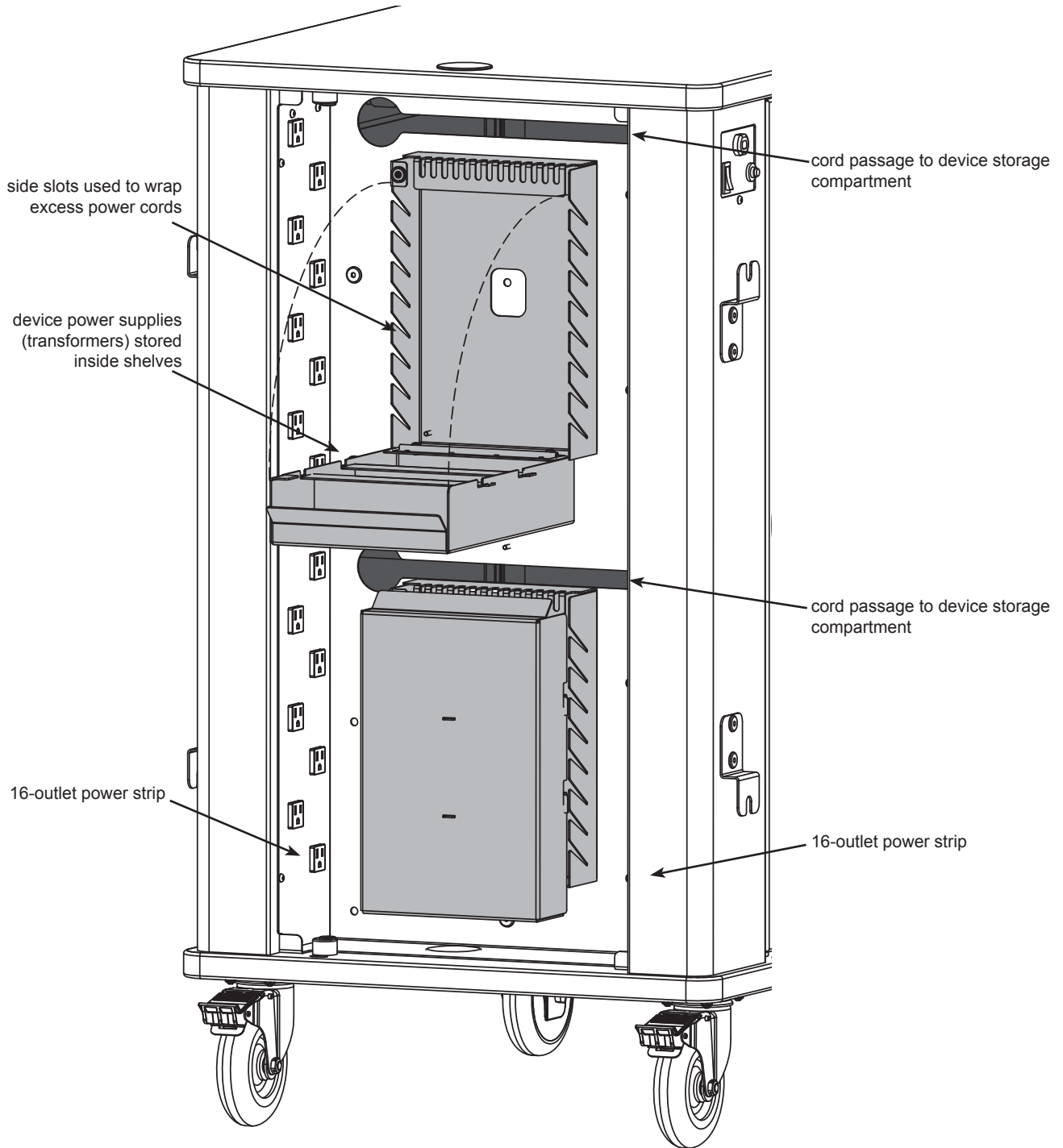

Note: The optional power cord organizers are used to manage and conceal power cords and (transformers). The side slots are used to wrap the cords, and three shelves in each flip-up panel store the power supplies.

Options

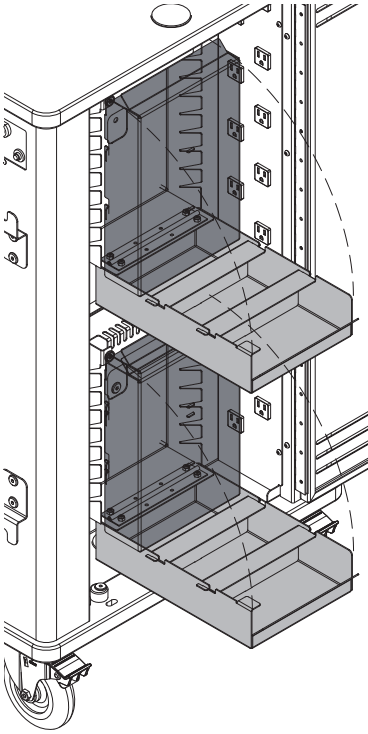

Power Cord Organizer
 (2 shown-max 2 per cart)
 8"W x 5¹/₁₆"D x 13"H
 55488

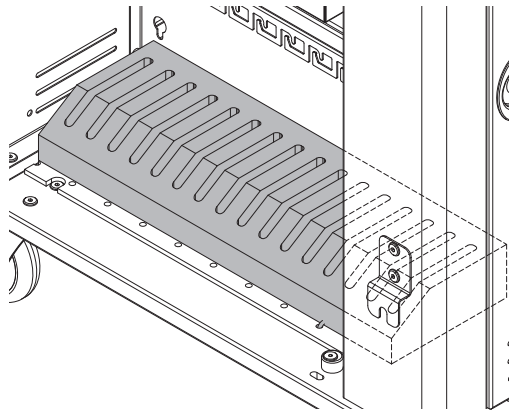

Small Device Foam Module
 stores smart phones & other small devices
 (16 slots)
 overall size: 23"W x 7¹/₂"D x 3"H
 slot size: 1/2"W x 5¹/₂"D x 1⁵/₁₆"H
 55486

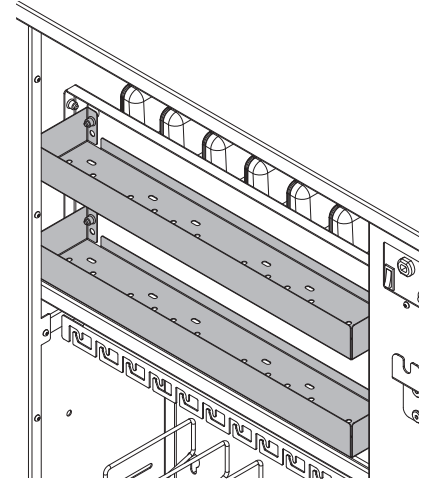

Power Supply Tray
 storage for cords, power supplies,
 or additional items
 21¹⁵/₁₆"W x 3¹⁵/₁₆"D x 1¹⁵/₁₆"H
 (max 2 per divider panel)
 55487

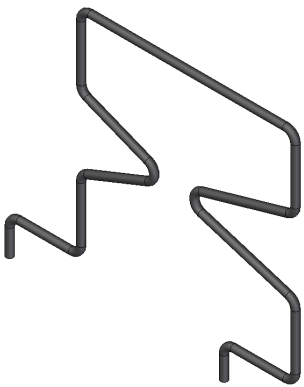

Wire Divider Kit
 8 included
 55485



Velcro® Strap Kit
 (16) 3/4" x 12"
 (32) 3/4" x 5" straps
 95004

Warranty

WE WILL MAKE IT RIGHT FOR YOU!

Spectrum is committed to provide complete customer satisfaction. Each of our products are manufactured from the best materials available and each product is stringently monitored throughout the production process through our P.A.C.E. program (Product Assurance to meet Customer Expectations). Our Customer Service Help Line 1-800-235-1262 is ready to provide immediate attention to any questions, comments or concerns. We are available to answer your calls Monday through Friday from 7 am to 5 pm CST, excluding observed holidays. In addition your product comments or concerns are welcome via e-mail at: spectrum@spectrumfurniture.com.

Warranty Statement

We guarantee all Spectrum products to be free of all defects in materials and workmanship, for the original owner, for a period of ten years. Any item deemed defective by Spectrum or the original manufacturer, under normal use conditions, will be repaired or replaced at Spectrum's discretion. This warranty applies to all products manufactured and distributed by Spectrum except the products listed below.

Items that have a varying warranty include, but are not limited to, the following:

- Adjustable Crank/Electric Desk Legs (1 yr)
- Flat Panel Desk Gas Cylinders (1 yr)
- Upholstered Soft-Goods (5 yrs)
- Adjustable Height & Stacking Chair Parts – including frames, gas cylinders, wood and plastic parts, and control handles (7 yrs)
- Adjustable Height & Stacking Chair Casters (2 yrs)
- Chair Upholstery & Textiles (2 yrs of normal use of Soft Goods, Adjustable Height, Stacking, Wood and Metal Chairs)
- Chair Upholstery - Graded-In Fabrics and C.O.M (no warranty)
- Height Adjustable Columns and Lifts (1 yr)
- General Use Casters (1 yr)
- Electrical – Electri-Pak, Power Communication Modules, and special order ECA electrical items (1 yr)
- Electrical - Power Strips & Electrical Timers (1 yr)
- Electrical Surge Suppressors (lifetime)
- Electrical - Retractable Power Cords (1 yr)
- Keyboard/Mouse Trays (1 yr)
- Flat Panel Monitor Arm – General Parts (5 yrs)
- Flat Panel Monitor Arm – Gas Cylinders (2 yrs)
- CRT Monitor Arm (1 yr)

Warranty is void if product is not used for its intended purpose or subjected to an unusual application, multiple-shift use, alteration, accident, abuse or abnormal wear and tear. Representations of colors on-line and in printed materials are meant to be a close reference to the actual colors but not an exact match. Slight variations in color and texture of wood stains, powder coating, laminates, fabrics and other materials are normal in different manufacturing lots; as such these variations are not considered defects.

DESIGNED FOR INDOOR USE ONLY – Unless specifically stated in the product specifications, Spectrum's products have been designed and constructed for indoor use only. Moving or using outdoors, or on excessively rough surfaces, may cause damage to the products and will void the warranty. If an outdoor application is desired please contact us to discuss potential custom design solutions.

The warranty, as stated above, supersedes any previous warranties and is effective as of 9/1/2010



205 Westwood Ave, Long Branch, NJ 07740
Phone: 866-94 BOARDS (26273) / (732)-222-1511
Fax: (732)-222-7088 | E-mail: sales@touchboards.com



INDOOR AIR QUALITY
Indoor Advantage | Furniture

