

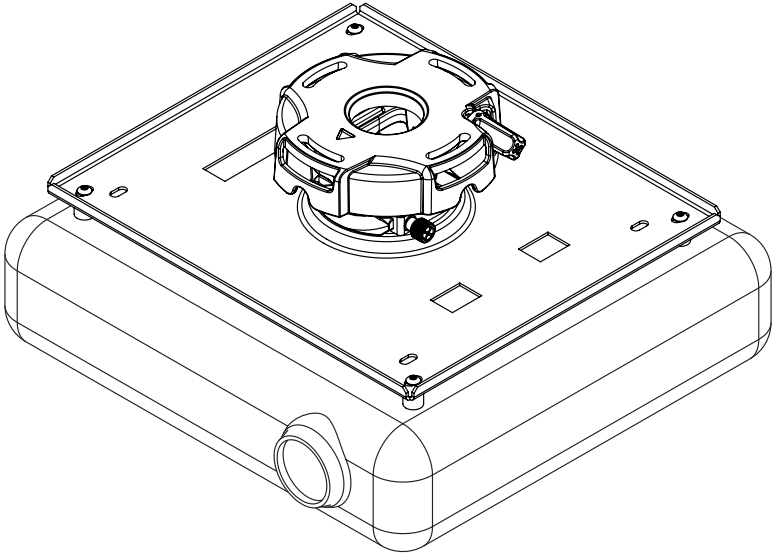

NEC Display Solutions of America, Inc.

Ceiling Mount for NEC NP1150, NP2150, NP3150, NP3151W, NP1250, NP2250, NP3250, NP3250W, NP-PA500U, NP-PA500X, NP-PA600X, NP-PA550W, NP-P502WL, NP-P502HL, NP-PA521U, NP-PA571W, NP-PA621X, NP-PA622U, NP-PA672W, and NP-PA722X Projectors

PA600CM

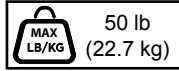

ENG	Compatible model/series*	AEC*, ALU*, EXT*, SCP200
-----	--------------------------	-----------------------------------



⚠ WARNING

ENG - This product is designed to be installed on wood joist/beam or solid concrete ceilings. Hardware is included for wood joist/beam and solid concrete installation. Before installing make sure the supporting surface will support the combined load of the equipment and hardware. Screws must be tightly secured. Do not overtighten screws or damage can occur and product may fail. Never exceed the Maximum Load Capacity. Always use an assistant or mechanical lifting equipment to safely lift and position equipment. This product is intended for indoor use only. Use of this product outdoors could lead to product failure or personal injury. Be careful not to pinch fingers when operating the mount. For support please call customer care at 1-800-865-2112.

ENG Symbols



ENG WARNING



ENG Skip to step.



ENG Screws must get at least three full turns and fit snug.

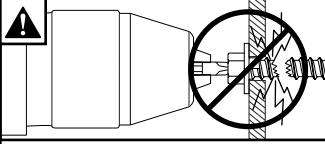

ENG Do not overtighten screws.



ENG Front of mount.

ENG Tools Needed for Assembly.

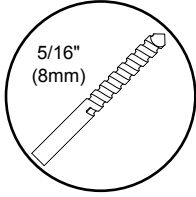
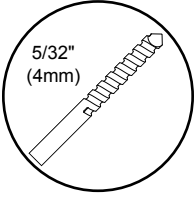
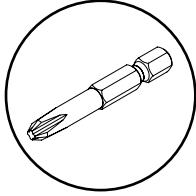
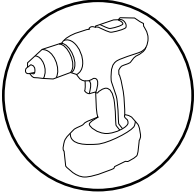
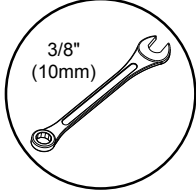
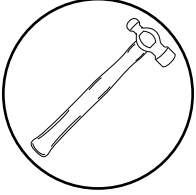
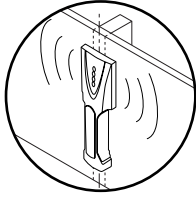
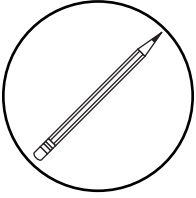

ENG To properly tighten screws: Tighten until screw head makes contact, then tighten another 1/2 turn. Do not overtighten screws.

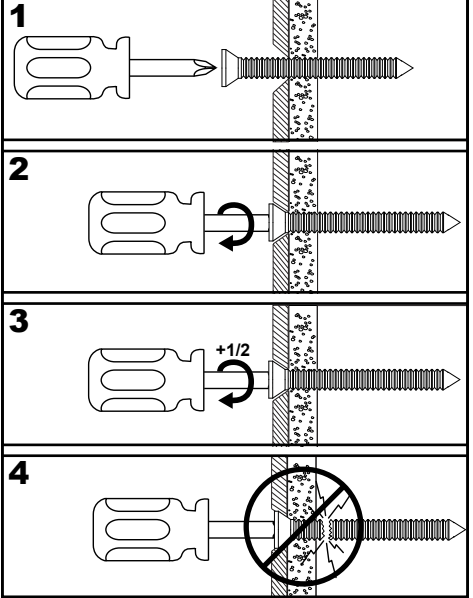

ENG Parts (Before beginning, make sure you have all parts shown below).

Parts List		
Description	Qty	Part #
A projector mount assembly	1	054-2171
B connection block	1	580-4400
C 4 mm security allen wrench	1	560-9646
D concrete anchor	2	590-0320
E #14 x 2.5 phillips hex head wood screw	2	5S1-015-C04
F #10-32 x 3/8" serrated socket pin screw	2	520-2151
G #10-32 x 1/4" socket pin screw	1	520-2196
H flat washer	2	540-2078
I 2 mm security allen wrench	1	560-1097
J adapter plate	1	055-2999
K M4 x 25 mm serrated socket pin screw	4	510-2082
L spacer	4	590-2106

A (1)

projector mount assembly

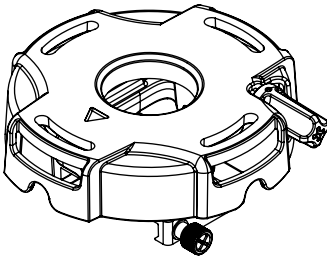

B (1)

connection block

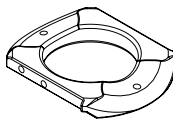

C (1)

4mm security allen wrench



I (1)

2mm security allen wrench



D (2)

8mm concrete anchor

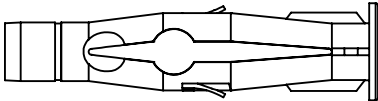

E (2)

#14 x 2-1/2" wood screw

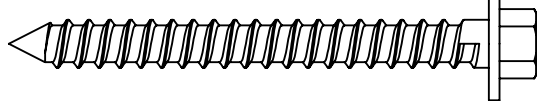

F (2)

#10-32 x 3/8"

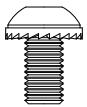

G (1)

#10-32 1/4"



H (2)

washer

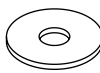

J (1)

adapter plate

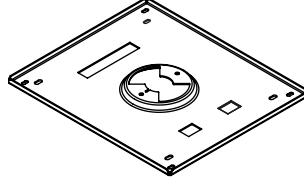

K (4)

M4 x 25mm



L (4)

spacer

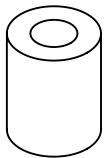

1

ENG Wood joist/beam

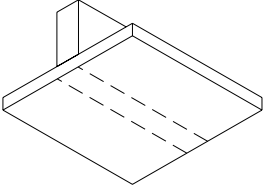

2a

ENG Extension Column (not included)

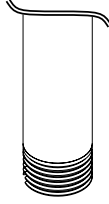

2b-1

ENG Concrete Ceiling

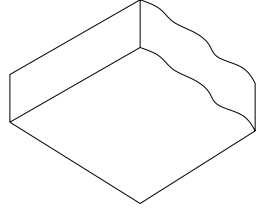

2c

2a

▲ WARNING

ENG - When installing Peerless ceiling mounts on a wood joist/beam covered with gypsum board (drywall), verify that the joists or beams are a minimum of 2" x 4" nominal size. Do not install over gypsum board thicker than 5/8".

2a-1

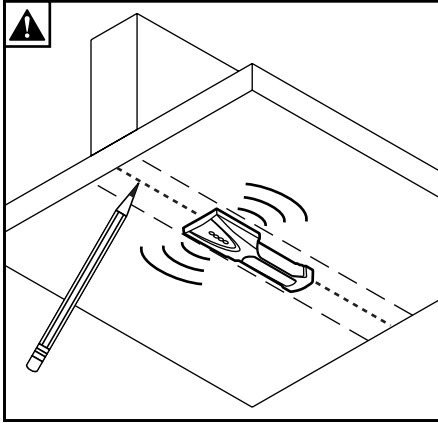
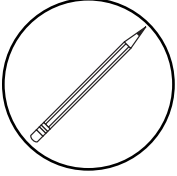
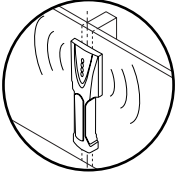

ENG Use stud finder to locate and mark stud center lines.

2a-2



ENG Mark mounting holes on stud center lines.

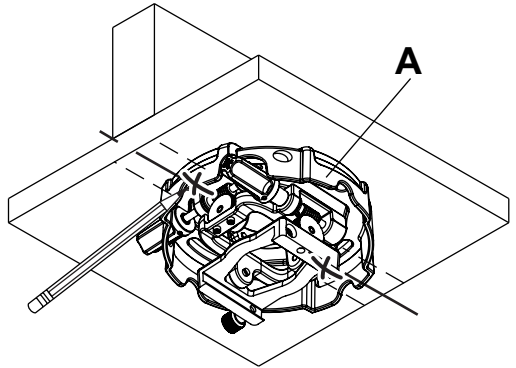

2a-3

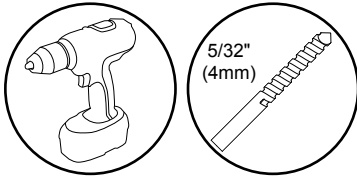

ENG Drill mounting holes into supporting surface (2.5" (64 mm) minimum depth required).

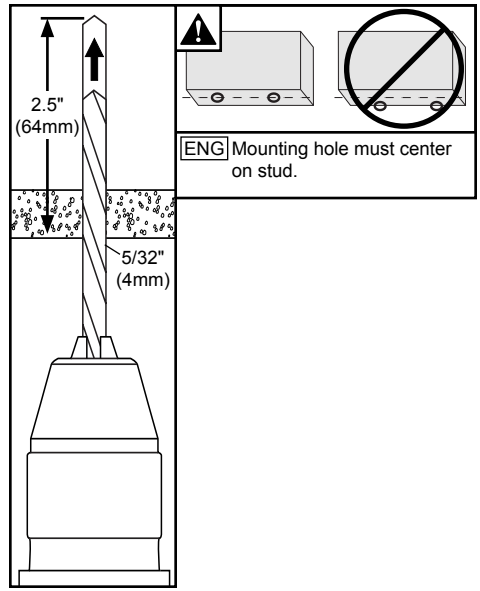

2a-4

ENG Install using wood screws provided.

ACCESS SLOT FOR OPEN END WRENCH ALLOWS TIGHTENING OF WOOD SCREW (E).

WOOD JOIST

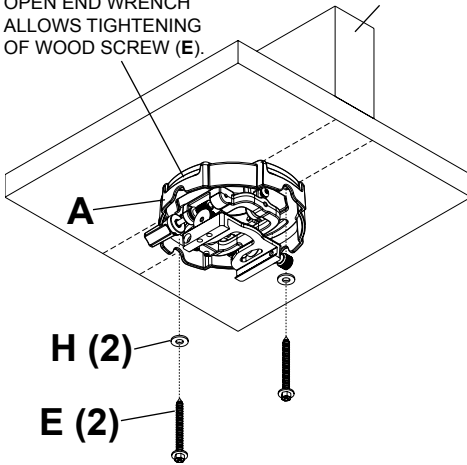

WOOD JOIST

ACCESS SLOT FOR OPEN END WRENCH ALLOWS TIGHTENING OF WOOD SCREW (E).

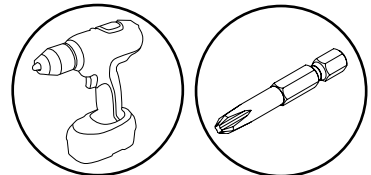
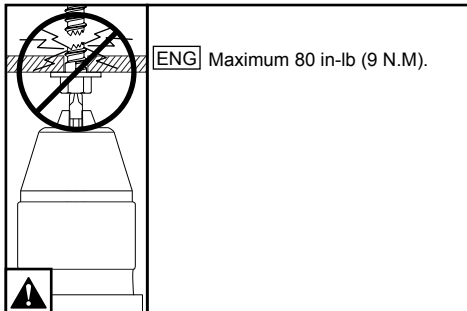
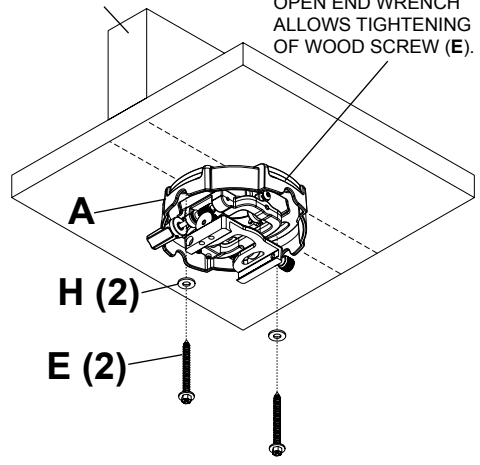

2b-1

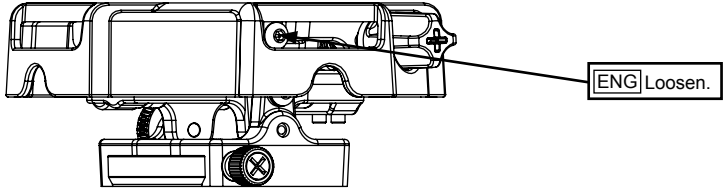
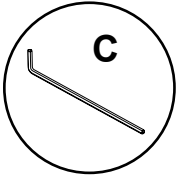

2b-2

ENG Rotate mount at least three full turns onto UL listed EXT, AEC or ALU series extension column (sold separately).

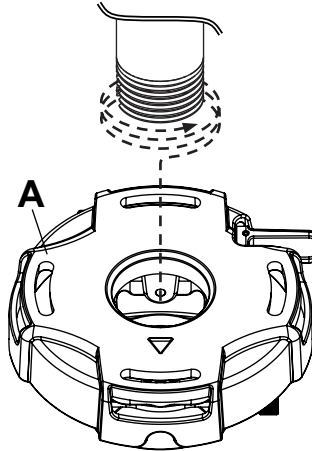

2b-3

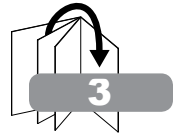
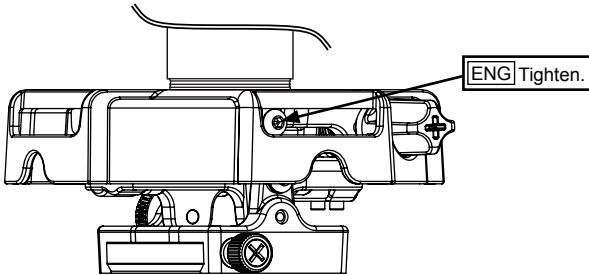
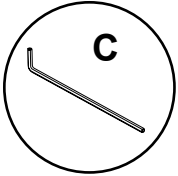

2c

▲ WARNING

ENG - When installing Peerless ceiling mounts on a concrete ceiling, the ceiling must be at least 8" thick with a minimum compressive strength of 2000 psi. Never attach concrete expansion anchors to concrete covered with plaster, drywall, or other finishing material.

2c-1



ENG Mark mounting holes.

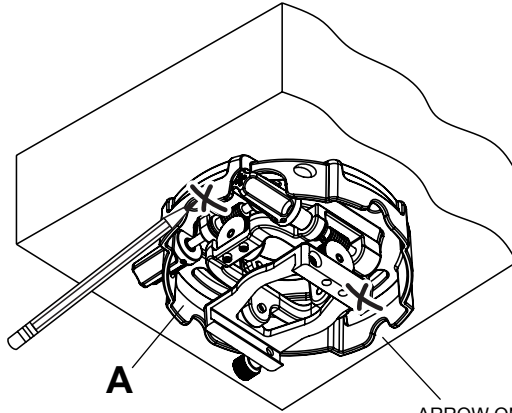

ARROW ON TOP OF
PROJECTOR MOUNT
ASSEMBLY INDICATES
FRONT OF MOUNT.

2c-2

ENG Drill mounting holes into supporting surface (2.5" (64 mm) minimum depth required).

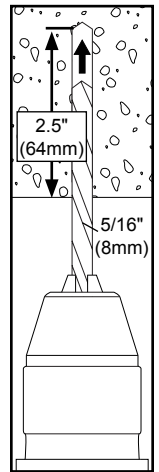
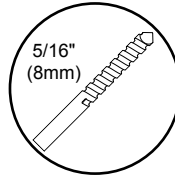

2c-3

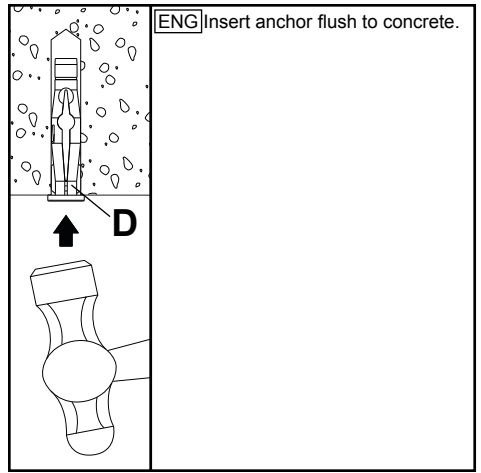
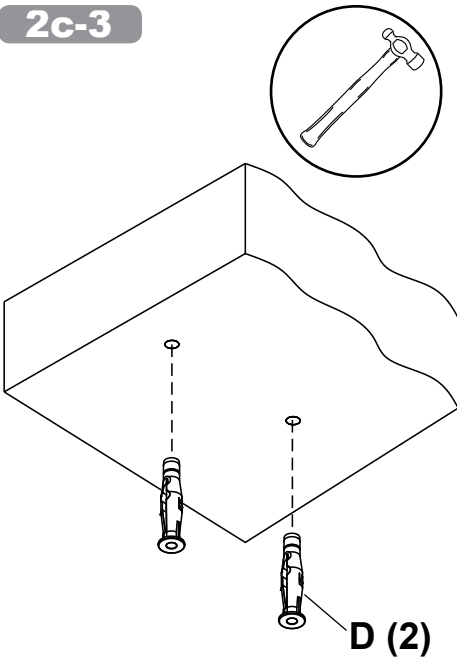

2c-4

ENG Install using concrete anchors and wood screws provided.

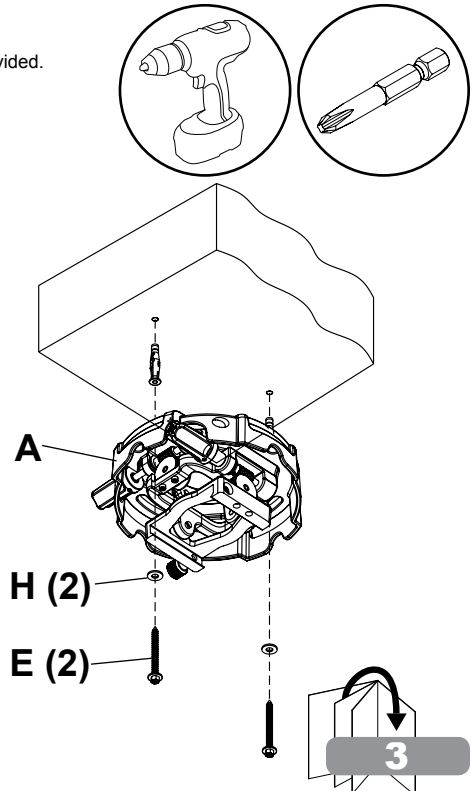
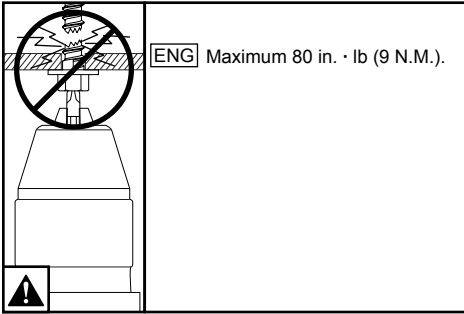

3

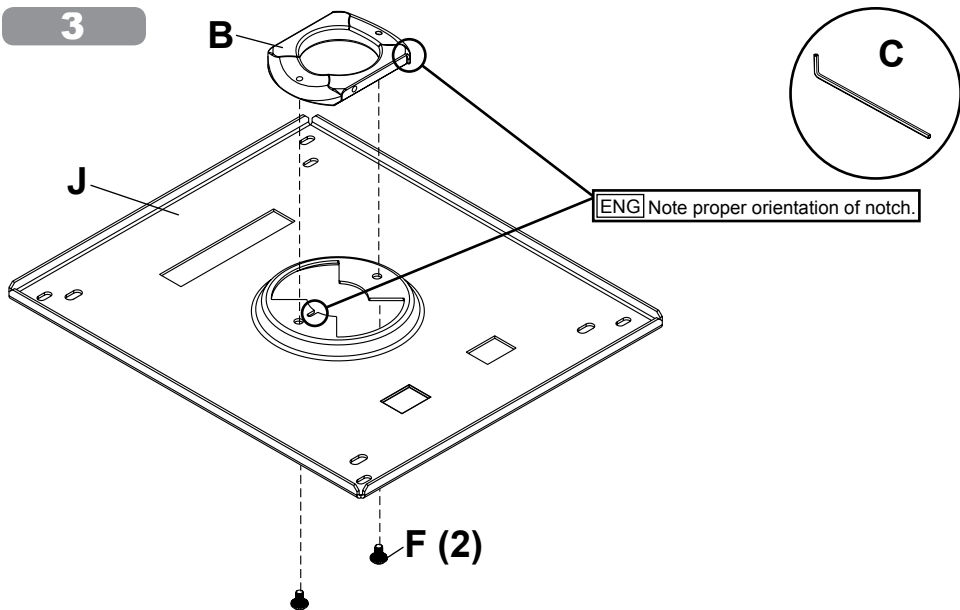

3-1

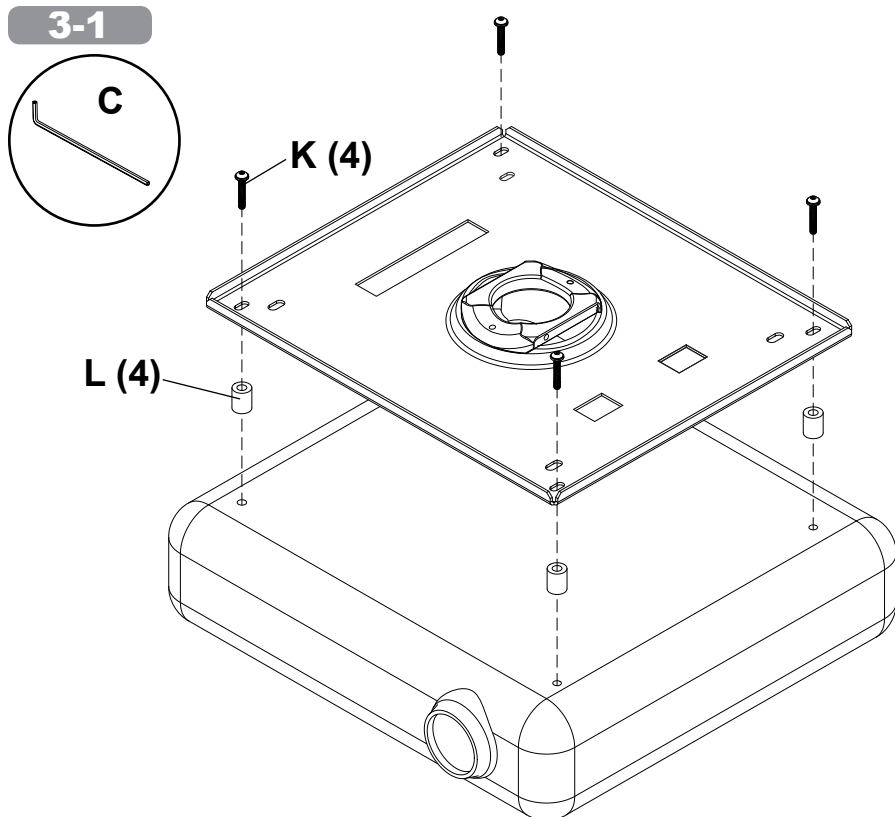

4-1

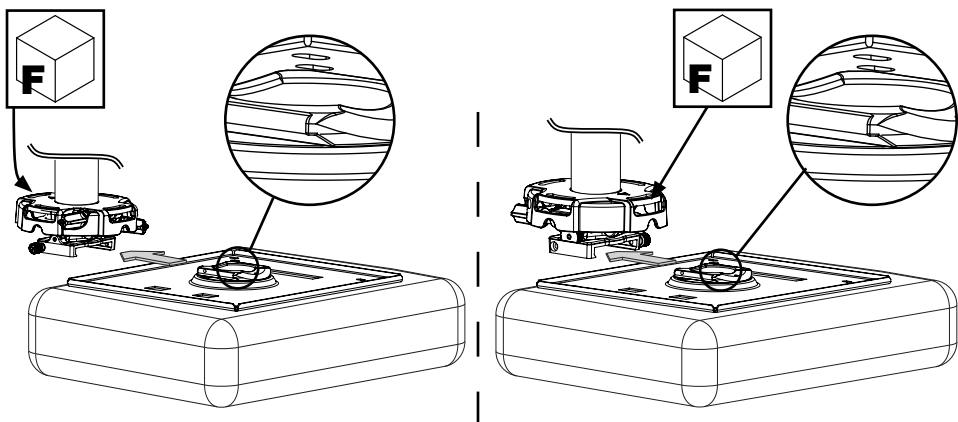

4-2

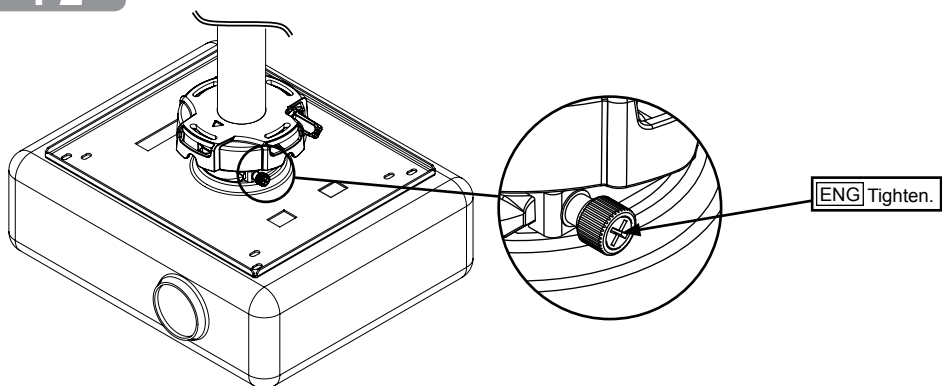

4-3

ENG Optional security screw.

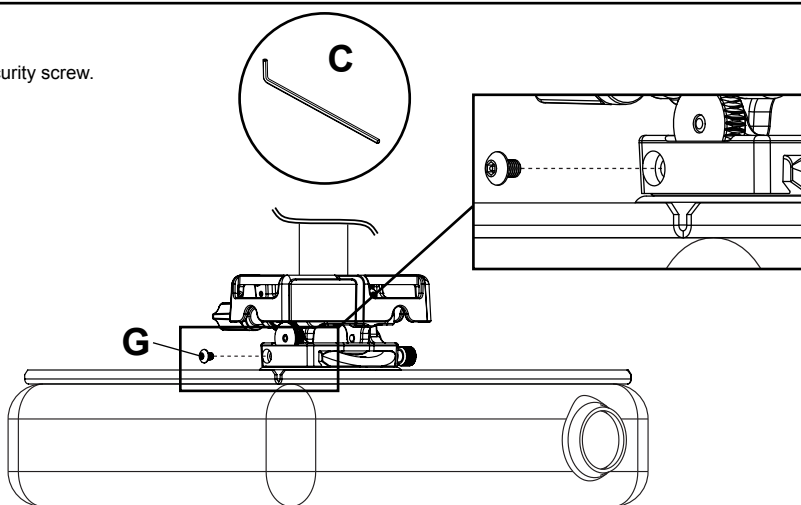

5

ENG Cable management: adjust pitch then route cables as shown.

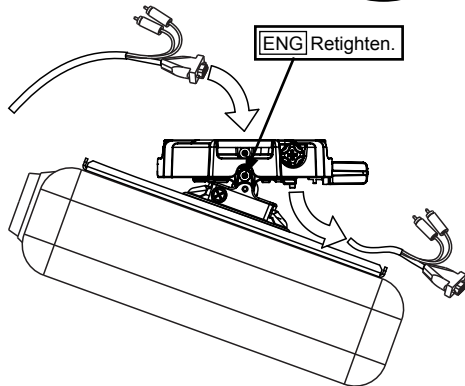
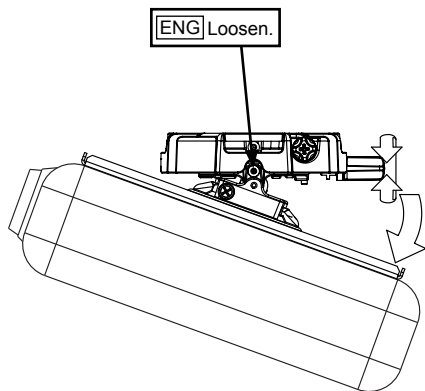
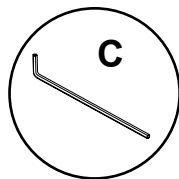

6-1

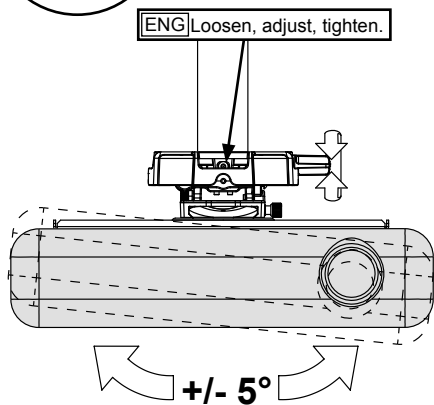
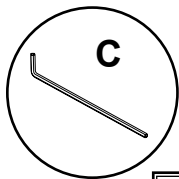

6-2

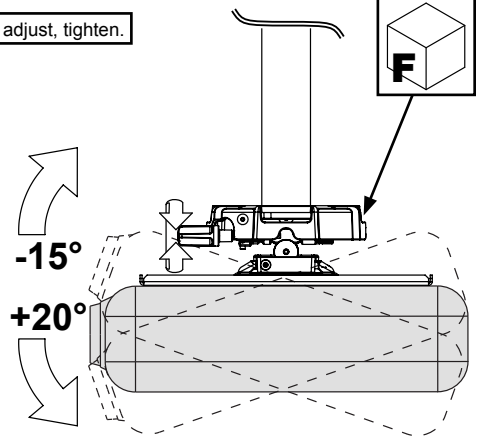
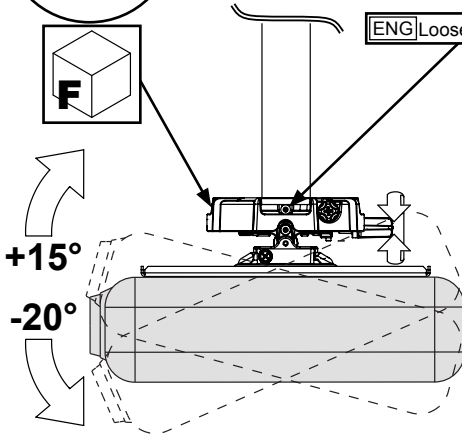
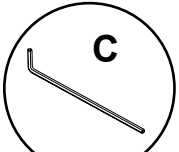

6-3

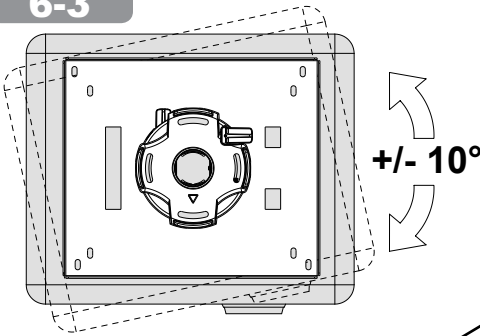

ENG Loosen, adjust, tighten.

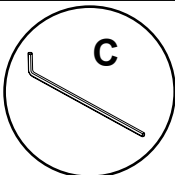
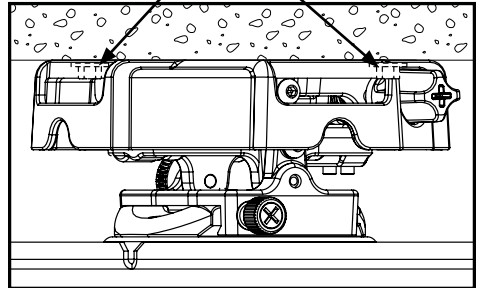
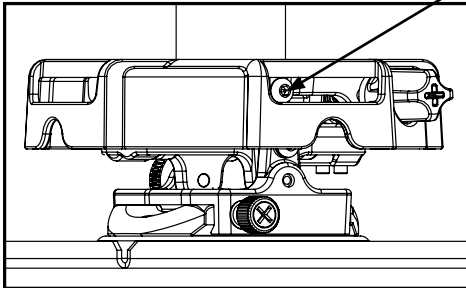

LIMITED FIVE-YEAR WARRANTY

Peerless Industries, Inc. ("Peerless") warrants to original end-users of Peerless® products will be free from defects in material and workmanship, under normal use, for a period of five years from the date of purchase by the original end-user (but in no case longer than six years after the date of the product's manufacture). At its option, Peerless will repair or replace, or refund the purchase price of, any product which fails to conform with this warranty.

In no event shall the duration of any implied warranty of merchantability or fitness for a particular purpose be longer than the period of the applicable express warranty set forth above. Some states do not allow limitations on how long a implied warranty lasts, so the above limitation may not apply to you.

This warranty does not cover damage caused by (a) service or repairs by the customer or a person who is not authorized for such service or repairs by Peerless, (b) the failure to utilize proper packing when returning the product, (c) incorrect installation or the failure to follow Peerless' instructions or warnings when installing, using or storing the product, or (d) misuse or accident, in transit or otherwise, including in cases of third party actions and force majeure.

In no event shall Peerless be liable for incidental or consequential damages or damages arising from the theft of any product, whether or not secured by a security device which may be included with the Peerless® product. Some states do not allow the exclusion or limitation of incidental or consequential damages, so the above limitation or exclusion may not apply to you.

This warranty is in lieu of all other warranties, expressed or implied, and is the sole remedy with respect to product defects. No dealer, distributor, installer or other person is authorized to modify or extend this Limited Warranty or impose any obligation on Peerless in connection with the sale of any Peerless® product.

This warranty gives specific legal rights, and you may also have other rights which vary from state to state.



Peerless-AV

2300 White Oak Circle
Aurora, IL 60502
Email: tech@peerlessmounts.com
Ph: (800) 865-2112
Fax: (800) 359-6500
www.peerless-av.com

© 2015, Peerless Industries, Inc.

Peerless-AV Europe

Unit 3 Watford Interchange,
Colonial Way, Watford, Herts,
WD24 4WP, United Kingdom
Customer Care
44 (0) 1923 200 100
www.peerless-av.com

© 2015, Peerless Industries, Inc.

Peerless-AV de Mexico

Ave de las Industrias 413
Parque Industrial Escobedo
Escobedo N.L. Mexico 66050
Servicio al Cliente
01-800-849-65-77
www.peerless-av.com

© 2015, Peerless Industries, Inc.