

Specifications

Output	Modbus RTU Digital
Accuracy	+/-1% Full Scale (Input Signals) Analog to digital through 10 bit processor.
Power Supply	24VDC, 120VAC, or 240VAC, +/- 10% 2-wire - 14AWG max., 75°C copper wire only.
Power Consumption	50mA powered by 120 VAC 25mA powered by 240 VAC 200mA powered by 24VDC - <i>Use UL listed fuse (type JDYX) one amp max.</i>
Inputs	8 4-20mA inputs, three configurations: 1: Converter supplies 20.6 to 26 VDC to drive the input sensor signal(s) 2: 4 powered and 4 passive inputs 3: 8 passive inputs, powered from an external source (0-5/10VDC available in this configuration only).
Output:	Switch selectable 9600 or 19200 baud RS485 Protocol; 1 Start bit, 8 data bits, even parity, 1 stop bit Data scaled to 0% at 4mA (or zero VDC) to 100% at 20mA (or 5/10VDC) +/-1% 3 wide, (D+, D-, GND) Finger-safe captive screw, 16-26 AWG rated 75 deg. C minimum.
Output Terminals	
Addressing:	8 wide binary weighted switch, addresses 1-247 (not zero)
Modbus	Slave, RTU (remote terminal unit) interface. Only function 04, "Read Input Registers" is supported
Indication	Green LED: Power On Yellow LED: Busy (working on a response to its address) Red LED: Fault On when there is: a. An error in the query sent by the master, parity, missing stop bit b. Address set incorrectly c. Function code is not four d. Packet is less than three bytes e. Failed CRC test No response is made when Fault LED is on
Environmental	-4 to 122 DegF, (-20 to 50 Deg C) Pollution degree 2
Dimensions:	3.7"D (94mm) x 5.0"W (127mm) x 2.5"H (64mm)
Mounting:	35mm DIN Rail
Weight:	11.2 oz., 318 grams

Model Number Key

ADC 1 - 420 - 120 - MOD - DIN

				Case Style
				DIN 35mm DIN rail
				Digital Output Protocol
			MOD	Modbus RTU
				Power Supply
			24D	24 VDC
			120	120 VAC
			240	240 VAC
				Analog Inputs
	420	-		4-20mA analog signals
	005	-		0-5 VDC analog signals (ADC3 only)
	010	-		0-10 VDC analog signals (ADC3 only)
				Input Signal Type
	1			8 two-wire loop powered signals, internally powered
	2			4 loop powered and 4 external powered inputs
	3			8 external powered inputs (Voltage inputs only available in this configuration)

ADC Series Analog to Digital Converter

Note for 24 VDC Supply:

The input must be protected with a UL listed fuse (UL JDYX) of 1 amp rating maximum, in series with the power input terminal and a 24V isolating source.

Description

ADC Series converters accept up to eight 4-20mA analog inputs, powered from the converter or from an external source depending on the sensor type used. Unit can be supplied for 0-5 and 0-10 VDC sensor inputs (external power only). The ADC unit will convert the sensor output signal to digital format so they can be read across a communications network.



NK Technologies

3511 Charter Park Drive, San Jose, CA 95136
Toll free: 800-959-4014, Phone: 408-871-7510
Fax: 408-871-7515
sales@nktechnologies.com, www.nktechnologies.com



INSTRUCTIONS



ADC Series
Analog to Digital Converter

Quick "How To" Guide

1. Mount ADC Analog Converter to DIN rail in suitable enclosure. Set baud rate as required. Set Modbus address.
2. Connect 4-20mA (or 0-5/10VDC) sensor outputs to the converter input terminals. Depending on the model, the loop power may be produced by the converter internally. Voltage output sensors do not use loop power.
3. Connect the power supply (24VDC, 120 or 240 VAC) to the power supply terminals. Use up to 14 AWG copper wires rated to 75°C minimum. Tighten to 7-in-lbs.
4. Connect the Modbus output to the field supplied controller.
5. Energize the converter and read the Modbus output, scaled as 0% at 4mA (or 0 volts) sensor output, 100% at 20mA (or 5/10VDC) sensor output.

Wiring

Sensors (ADC Inputs)

Connect the sensor outputs to the ADC terminal blocks 6-21 as shown in the drawing below, following the product labeling, using 16-26 AWG copper conductors, minimum temperature rating 75 degrees C. Tighten terminals to 5-7 in-lb torque. Double check that the sensors used are appropriate for the converter selected. ADC converters are factory set to accept 2-wire or 4-wire sensors, or a combination of both.

Power Supply Connection:

Depending on the model, supply 120 VAC (hot and neutral) to the terminals 1 and 2; or 240 VAC (hot and hot) to terminals 1 and 2. For 24VDC models, connect ground to terminal 2, +24 VDC to term. 1. **DO NOT REVERSE!** Maximum power consumption is 6 VA.

The converter does not need an equipment ground. The green LED will light when power is supplied.

Output Connection:

Connect output wiring to supervisory or other controller using terminals 3-5: 3= ground (GND), 4= D+ and 5= D- Set baud rate to match your network using the switch to

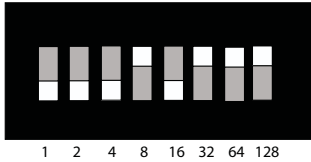

the right of the power supply terminals.

Network Node Address:

The node address is set through series of eight dip-switches allowing a possible address range of 1-247. The binary value of each switch is stenciled onto the circuit board, and the switch is “on” with the handle pushed to the lower position. As an example, the illustration above shows the address set at the decimal value of 23. Note that the switch reads from left to right.

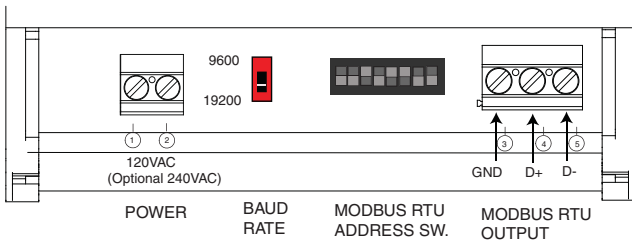

Lower terminals, power supply, baud rate selection, Modbus address selection and Modbus output connections

Wiring and Modbus Field Description

Field supplied sensors connect to terminals 6-21, reading from right to left as shown below and on the product label.

Numeric values are shown in **hexadecimal** format in **blue**. Messages start with a silent interval of 3.5 character times, scaled to the baud rate. The ADC monitors the network bus continuously, The first field transmitted is the device address. When received, and it matches the switch setting, the rest of the data is available. The query from the master device “Start data location hi” is always **00**, and the “start data location lo” is the lowest channel to be read, selected by sending **00** for channel one, **01** for channel two, up to **07** for channel eight. For channel numbers greater than **07** the responses will be function code **84** and **02** and CRC.

Each channel returns two bytes, with the “number of channels hi” always **00** and the “number of channels lo” between **01** and **08**. A request to read channel six would be: “Start data location lo **05** and “Number of channels lo” **01**. A request to read channels 4,5 and 6 would be “Start data location lo” **03** and “number of channels lo” **03**. A request to read all eight channels would be “Start data location lo” **00** and “Number of bytes lo” **08**.

A typical request from the Master using network address 23 (**17**) to read all 8 channels:

17 04 00 0F

A typical response from the ADC unit, all channels at 100% of sensor range:

17 04 10 00 64 00 64 00 64 00 64 00 64 00 64 00 64 00 64 B298 (CRC)

Top terminals for sensor inputs

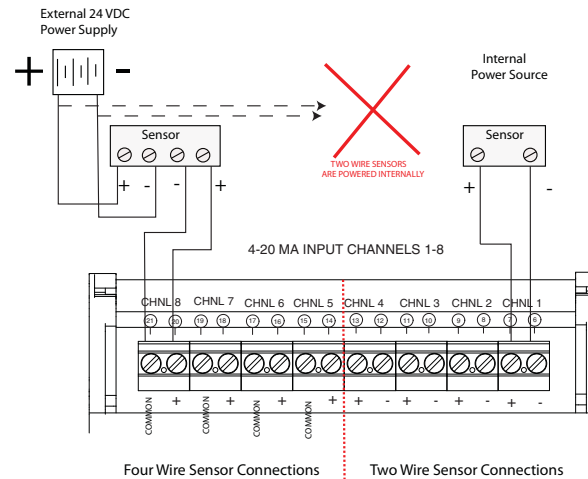

ADC converters can be configured for two or four wire inputs. Be certain not to add external voltage to the two wire inputs! Also note that the positive terminal are odd numbered for 2-wire inputs, and even numbered for 4-wire inputs.

The data from each channel is a two byte field, with the first byte zero (decimal) and the second a value between zero and 120 (decimal). 4mA (or 0 VDC) (+/-1%) becomes zero, and 20mA (or 5/10VDC becomes 100% +/-1%. A reading more than 1% below 4mA is an error: **00** and **AA**. A reading over 23mA is an error: **00** and **FF**. All measurements are made using a ten bit analog to digital converter. All passive inputs (4-wire) share the same ground on the ADC converter, please be sure that this will work in your installation.

Modbus Register Map

Register	Address	Type	
01	30001	16 bit integer	Zero, channel 1, MSB Percent full scale, channel 1, LSB
02	30002	16 bit integer	Zero, channel 2, MSB Percent full scale, channel 2, LSB
03	30003	16 bit integer	Zero, channel 3, MSB Percent full scale, channel 3, LSB
04	30004	16 bit integer	Zero, channel 4, MSB Percent full scale, channel 4, LSB
05	30005	16 bit integer	Zero, channel 5, MSB Percent full scale, channel 5, LSB
06	30006	16 bit integer	Zero, channel 6, MSB Percent full scale, channel 6, LSB
07	30007	16 bit integer	Zero, channel 7, MSB Percent full scale, channel 7, LSB
08	30008	16 bit integer	Zero, channel 8, MSB Percent full scale, channel 8, LSB

The error checking contains a 16-bit value implemented as two 8-bit bytes. This value is the result of a Cyclical Redundancy Check calculation performed on the message contents. The CRC field is appended to the last field in the message. The low-order byte is appended first, followed by the high-order byte, which is the last byte transmitted. Below is a typical response frame.

START	ADDRESS	FUNCTION	DATA	CRC	END
3.5 CHAR TIMES	1 BYTE	1 BYTE 04 HEX	EXPANDED BELOW	2 BYTES	3.5 CHAR TIMES

Function code is **04** with no errors, or **84** followed by **02** for out of bounds channel or incorrect “Number of channels lo”

Expanded data field:

BYTES TO FOLLOW	FIRST BYTE	SECOND BYTE	THIRD BYTE	FOURTH BYTE	FIFTH BYTE
0Y HEX	00 HEX	% DATA	00 HEX	% DATA	00 HEX

A minimum of five and a maximum of 21 bytes are returned to the master. The “Bytes to follow” is a minimum of **02** for a single channel or for an **84** function code and a maximum of **0F** for all eight channels.