

Specifications

Setpoint Range	AG1 Series: 5-100mA Field Adjustable AG2 Series: 80-950mA Field Adjustable AG3 Series: Tri-Set, 5, 10 & 30 mA, Jumper Select
Voltage Range	Up to 1,500 VAC (Monitored Circuit)
Frequency Range	50-400Hz (Monitored Circuit)
Output Description:	Latching electromechanical relay 1.0A @ 120 VAC, 2A @ 30 VDC NOR latches closed upon sensed fault current NCR latches open upon sensed fault current Status (Red) LED = Relay has operated
Response Time	200 ms @ 5% over setpoint. 60 ms @ 50% over setpoint. 15 ms @ 500% over setpoint
Power Supply	120 VAC Operates from 66-132 VAC (50-400Hz)
Optional Power	24 VAC or 24 VDC Operates from 19.2-28.8 Volts) Power (Green) LED=Power supply energized
Power Consumption	2.5 Watts
Dimensions	2.5"H x 2.8"W x 1.5"D, (64x71x38mm), aperture 0.75" (19mm) dia.
Case	UL 94V-O Flammability Rated
Environmental	5 to 158 DegF (-15 to 70 DegC), 0-95% RH, Non Condensing

Power Supply Notes

All low-current Ground-Fault Detectors are sensitive devices that require reasonable care in system design to avoid false trips caused by high electrical noise levels. Keep in mind that the best way to reduce noise in a system is to suppress it at its source.

1. Keep the detector power isolated from noisy circuits.
2. Do not power the detector with the same circuit that switches contactors or other high current, inductive

System Grounding

Good design practice and code require that all AC power systems be grounded. AG Series detectors are designed to work on grounded AC power systems. They may not operate properly on ungrounded systems.

Model Number Key

AG 1 - NCR1 - 120 - LA - 005

	Setpoint 005 to 950	Factory Adjusted Setpoint in mA (specify when ordering) Tri-Set, 5, 10 & 30 mA, Jumper Select
	TR3	
	Options LA Latching	
	Power Supply 24U 24 VAC/DC 120 120 VAC	
	Output Type NOR1 Normally Open (Form A) NCR1 Normally Closed (Form B)	
	Setpoint Range 1 5-100mA, Adjustable 2 80-950mA, Adjustable 3 Tri-Set, 5, 10 & 30 mA, Jumper Select	

AG Series Ground Fault Detector

Know Your Power



Other NK Technologies Products Include:

AC & DC Current Transducers
AC & DC Current Operated Switches
1 ϕ & 3 ϕ Power Transducers
Current & Potential Transformers (CTs&PTs)



NK Technologies

3511 Charter Park Drive, San Jose, CA 95136
Toll free: 800-959-4014, Phone: 408-871-7510
Fax: 408-871-7515
sales@nktechnologies.com, www.nktechnologies.com

TEquipment
USA
An Interworld Highway, LLC Company
Call Us 1.877.571.7901

NK Technologies

INSTRUCTIONS



AG1, 2 & 3 SERIES Ground Fault Detectors with Latching Relay Outputs

Quick "How To" Guide

1. **Run all current carrying conductors through detector window**
 - A. Use an auxiliary CT if conductors do not fit. Consult Factory for CT selection.
2. **Mount the detector to a surface if needed.**
3. **Connect output & power wiring.**
 - A. Use up to 14 AWG copper wires.
 - B. Make sure power and load matches those shown on the sensors' label.
4. **Test**
 - A. Pressing the "TEST" button tests the detectors internal circuits. CAUTION: The output and any connected loads will switch!

Description

AG Series detectors monitor all current carrying wires in single or three phase systems to detect ground faults. They provide a contact output that can operate relays, contactors or signal automation systems.

Principal of Operation

Under normal conditions, the current in one wire of a two wire load is equal in strength but opposite in sign to the current in the other wire. The two wires create magnetic fields that cancel, a condition known as “Zero Sum Current”. If any current leaks to ground (Ground Fault), the two currents become unbalanced and there is a net resulting magnetic field. The AG detector detects this minute field and changes the output state. This concept extends to three phase systems such as 3 wire Delta and to 4 wire Wye.

Single Phase (Phase & Neutral or Phase to Phase)

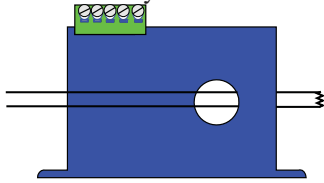

3 Phase Delta (Include neutral if the load uses neutral)

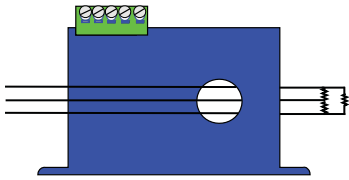

3 Phase Wye (Include neutral if load uses neutral)

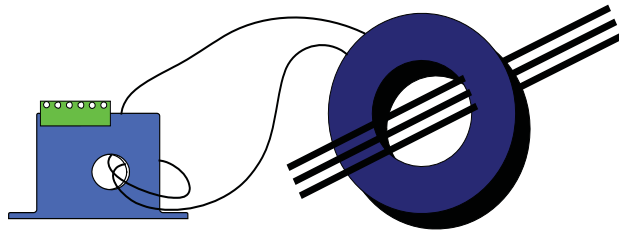
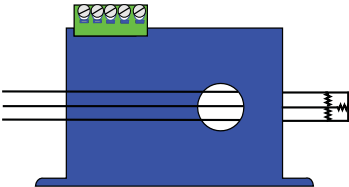

3 Phase Load, using an auxiliary Current Transformer. Contact factory for details.

Installation & Wiring

AG Series detectors work in the same environment as motors, contactors, heaters, pull-boxes, and other electrical enclosures. They can be mounted in any position or hung directly on wires with a wire tie. Just leave at least one inch distance between detector and other magnetic devices. Run all current carrying conductors through the opening in the detector. (See “Principal of Operation”) Be Sure all wires are oriented so current flows in the same direction.

Wiring

Use up to 14 AWG copper wire and tighten terminals to 4.5 inch-pounds torque. See Diagram.

Power

Connect power wiring to Terminals 1 & 2. Be sure that the power supply matches the power rating on the detector label.

Output

Connect output wiring to Terminals 3 & 4.

Reset Switch

Connect a momentary dry contact to the reset terminals (5 & 6.) Limit wire run to 200’ of 18 AWG or larger wire.

Operation

AG Series Latching Ground fault detectors operate in one of two states: Reset or Latched. If control power is removed, the detector remains in it’s last state (latched or reset).

Reset

The detector has not detected a fault and the output is in the “normal” position.

For -NOR1 suffix, the contact is normally open in the reset condition.

For -NCR1 suffix, the contact is normally closed in the reset condition.

Latched

Upon detecting a fault or when the TEST switch is pressed, the output will switch and “latch”. The output will remain latched until the ground fault is removed and the output is reset by a momentary dry contact on Terminals 5 & 6.

Testing

To test operation, gently press the TEST button. This simulates a fault and tests the internal switching circuits. After the test is complete, reset the detector with a momentary dry contact on Terminals 5 & 6. **CAUTION: Any circuit connected to the detector will be operated.**

Momentary Reset

The detector will not work properly if the reset terminals are closed (shorted) continuously. Only close the reset terminals momentarily.

Parallel Reset Connection

Multiple detectors may be connected to the same reset switch in parallel. Only the detectors that have detected a fault and have latched will be reset. A detector will not reset unless the fault has dropped below setpoint.

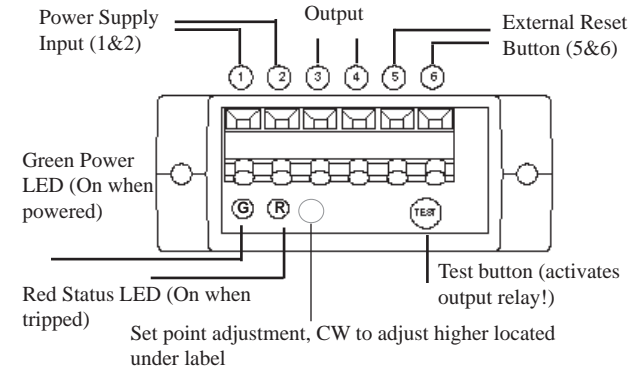

Field Setpoint Adjustment

While not as precise as having it set at the factory, the set point can be adjusted in the field through use of the small potentiometer located beneath the label to the right of the red LED (status). Though not recommended, if a field adjustment of setpoint is desired, the recommended steps are as follows:

1. Develop a load of the magnitude at which you want the detector to trip; e.g., a 4000 ohm resistor at 120 VAC should provide a load of 30 mA while 4 watt “night light” bulb would create a load of approximately 3.333 mA.
2. With the load energized and passing through the sensing aperture, turn the potentiometer clockwise (CW) until the detector trips. Then turn the pot back (CCW) one eighth of a turn.

When used with an external CT, the detector will be set to trip at a point much lower than without the CT. This set point adjustment should be done with the load passing through the CT in that application.