

ASXP-MS SERIES

Current Sensing Switches

ASXP-MS Series Current Switches combine a current transformer and signal conditioner into a single package. The large, easy-to-install split-core design allows for installation over existing conductors without the need to disconnect the load, even in applications where there are multiple conductors per phase. For new installations, the installation is just as easy. Just remove the top portion of the sensing ring, place the conductors inside, and snap the top back in place. The output relay energizes when the AC current through the sensing ring exceeds the adjustable setpoint, providing one contact to close and the other to open on current rise.

Current Sensing Switch Applications

Monitor Large Machines

- Detect over or undercurrent conditions before they cause break downs, or interlock one process with another.

Water Delivery and Treatment

- Detect open discharge lines.
- Sense clogged filters or blocked intake to pumps.

Generators

- Shed noncritical loads when demand reaches a set level.

Crusher Monitoring

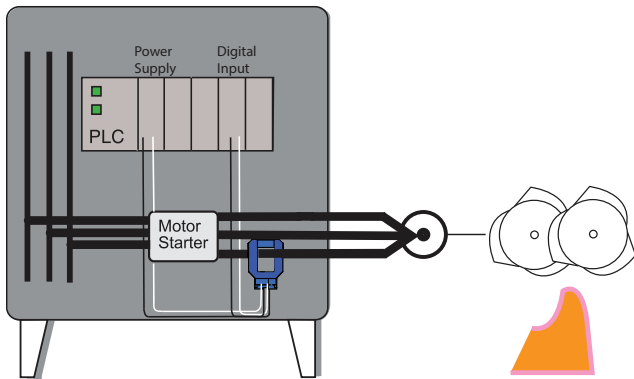

If the crusher drive draws too much current, the infeed belt can be stopped automatically, allowing the crusher to clear before restarting. The ASXP-MS provides a set of relay contacts for alarm of over or undercurrent conditions.

- For additional Application Examples, go to www.nktechnologies.com/applications

OEMs

Test & Evaluation Units for OEMs

Free program expedites evaluation process. See page 3 for details.

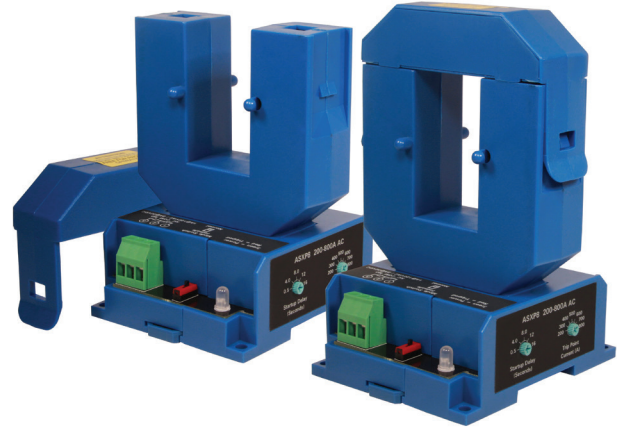

Current Sensing Switch Features

Electromechanical Relay Output

- Provides both normally open and normally closed contacts.
- Compatible with most automation and control systems.

Externally Powered

- Complete isolation between the sensor power and the controlled circuit.
- Provides a choice of failsafe* or standard operation.

Simple Field Setpoint Adjustment

- Single turn potentiometer with setpoint shown on label.
- Adjustable start delay to bypass inrush current.

Split-core Case

- Sensing window provides ample space for bus bar, single or multiple conductors.

DIN Rail** or Panel Mounted Case

- Simply snap onto DIN rail or attach with screws to a panel for secure mounting.

UL/cUL and CE Approved

- Accepted worldwide.

*For a description of failsafe operation, see the installation instructions.

**For information on the DIN rail accessories kit, see page 147.

Current Sensing Switch Connections

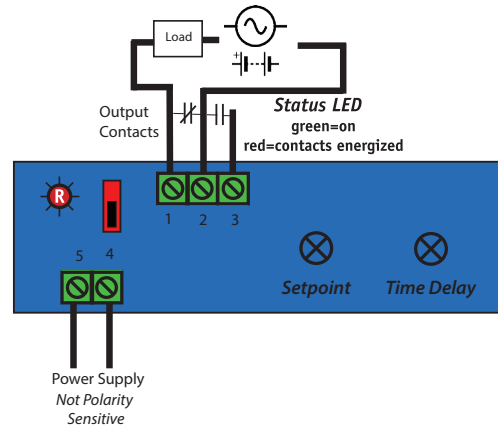

Current Sensing Switch Dimensions

MS Case

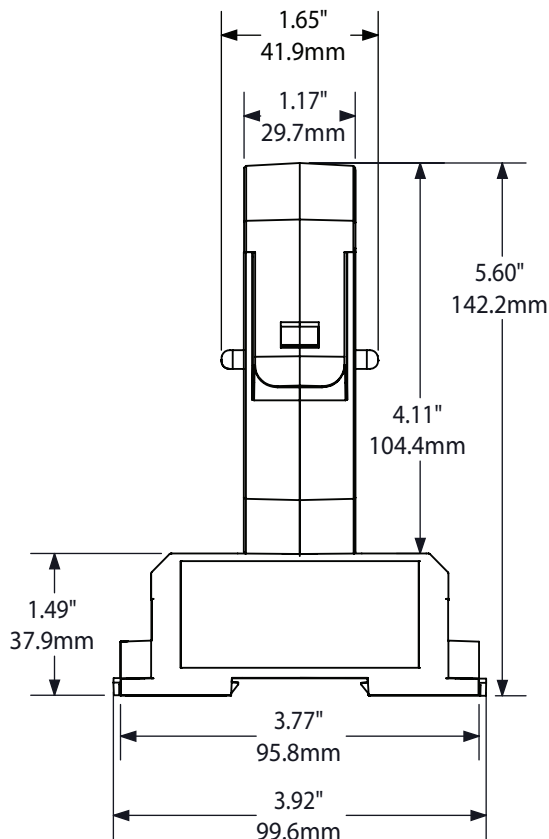
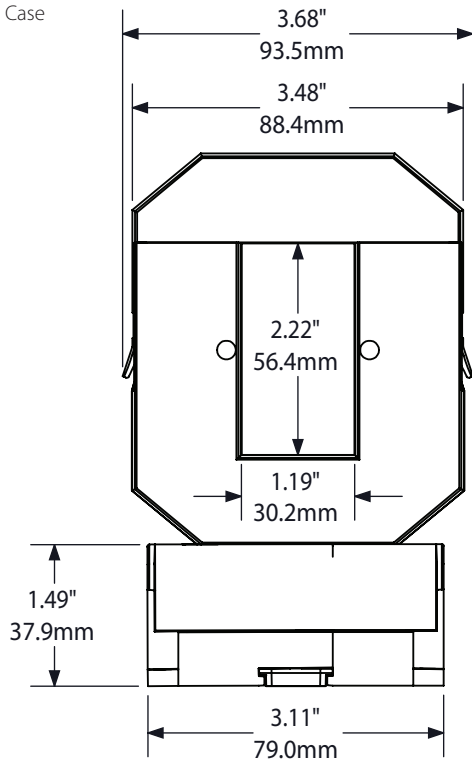

Current Sensing Switch Specifications



Power Supply	120 VAC (108-132 V) or 24 VAC/VDC (22-28 V)
Power Consumption	<4 VA
Input Range	<ul style="list-style-type: none"> • 2: 50-200 A • 4: 100-400 A • 6: 150-600 A • 8: 200-800 A
Output Switch	Electromechanical SPDT relay
Output Rating	1 A @ 120 VAC, 2 A @ 30 VDC max.
Indicating Bi-color LED	Green: Power on, current within range Red: Power on, current over setpoint Off: Power off or current less than 20% of range
Output Operation	Selectable: Normal or failsafe*
Time Delay	0.5 to 16 sec. (adjustable)
Hysteresis	5%
Isolation Voltage	UL listed to 2200 VAC
Frequency Range	40-100 Hz
Case	UL94 V-0 Flammability Rated
Environmental	-4 to 122°F (-20 to 50°C) Surrounding Air 0-95% RH, non-condensing
Listings	UL/cUL, CE

*For a description of failsafe operation, see the installation instructions.

Current Sensing Switch Ordering Information

Sample Model Number: AXSP8-SDT-120-MS
AC current switch, 200-800 A range, SPDT relay output, 120 VAC powered, medium split-core case, DIN rail mounting.



(1) Range

2	50-200 A
4	100-400 A
6	150-600 A
8	200-800 A

(3) Output Type

SDT	Single pole, double throw relay
-----	---------------------------------

(4) Power Supply

24U	24 VAC/VDC
120	120 VAC

(3) Case Style

MS	Split-core, base terminals, DIN rail mounting
----	---

Current Sensing Switches

