

ATP SERIES

AC Current Transducers

ATP Series AC Current Transducers sense currents from 0–200 A and provide a proportional analog VDC or mA output. Externally powered by 120 VAC/DC or 24 VAC/DC, the ATP Series AC Current Transducers eliminate the need for costly power supplies or voltage rectifiers inside the control panel. Designed for motor control applications with standard sinusoidal waveforms, these transducers feature user-selectable input ranges, a choice of outputs and split-core or solid-core cases.



AC Current Transducer Applications

Commercial and Industrial Motor Control Centers

- 120 VAC/DC power supply option allows for powering off of readily available supplies; ideal for pumping, water/wastewater, boiler and other industrial applications.
- Eliminates the need for 24 VDC power supply or AC rectifiers within the control panel; saves space, material and labor associated with power supplies.

Heater Failure Detection

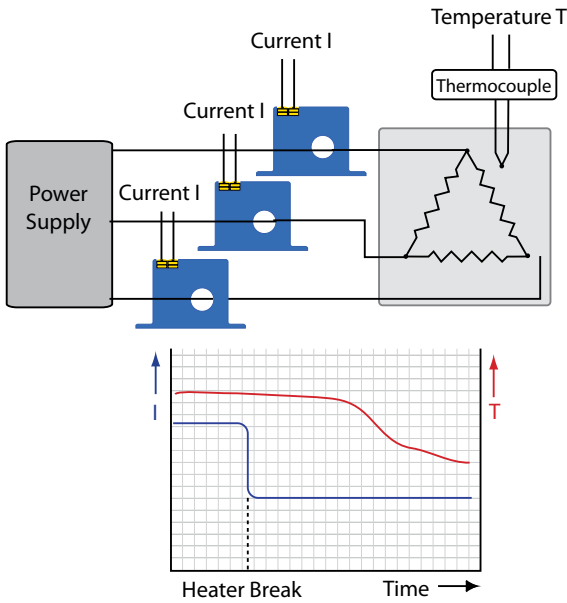

For additional Application Examples, go to www.nktechnologies.com/applications

OEMs Test & Evaluation Units for OEMs
Free program expedites evaluation process. See page 3 for details.

AC Current Transducer Features

Fast, Accurate RMS Measurement

- Unique ‘average responding’ algorithm provides RMS output on pure sine wave and constant speed loads, offering improved accuracy over two-piece solutions.

Jumper-selectable Input Ranges

- Each unit has multiple input range capability and can be used for a variety of applications, reducing the need for separate models.

Isolation Output

- Output is magnetically isolated from the input for enhanced safety and elimination of insertion losses.

Designed for UL/cUL and CE Approval

- Accepted worldwide.

AC Current Transducer Connections

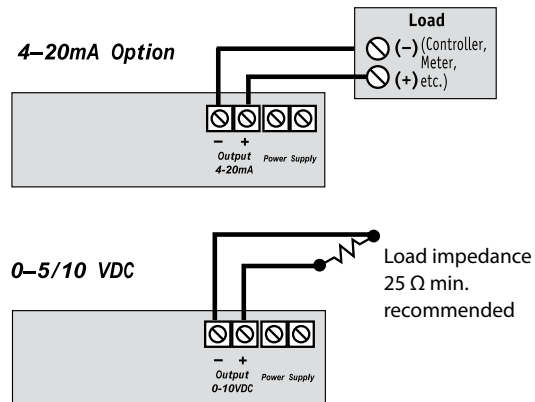

Notes:
Terminals are deadfront captive screw terminals.
Use 12–22 AWG solid or stranded.

AC Current Transducer Dimensions

FF Case

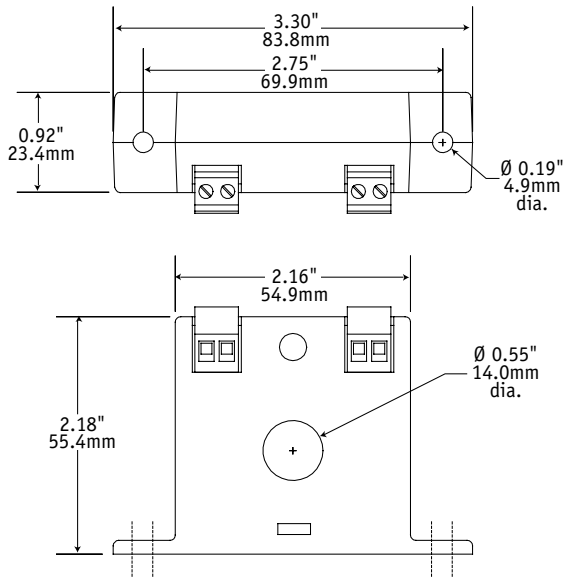

SP Case

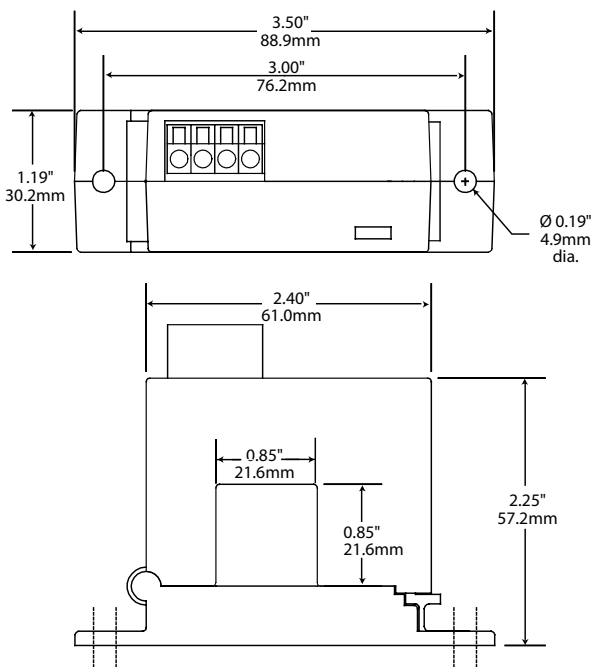

AC Current Transducer Specifications

Power Supply	• 120 VAC/DC (108–132 V) • 24 VAC/DC (22–26 V)
Power Consumption	<2 VA
Output Signal	• -005 Model: 0–5 VDC • -010 Model: 0–10 VDC • -420 Model: 4–20 mA
Output Limit	• -005 Model: 112% (5.6 V) • -010 Model: 112% (11.2 V) • -420 Model: 112% (22.4 mA)
Output Impedance	25 KΩ min.: VDC models 500 Ω max.: 4–20 mA models
Accuracy	1.0% FS
Response Time	100 ms (10–90% step change)
Frequency Range	40–100 Hz standard
Isolation Voltage	UL listed to 1270 VAC, tested to 5 KV
Input Range	0–200 A jumper-selectable
Case	UL94 V-0 Flammability Rated
Environmental	-4 to 122°F (-20 to 50°C) 0–95% RH, non-condensing
Listings	Designed for UL/cUL and CE approval

AC Current Transducers

AC Current Transducer Ordering Information

Sample Model Number: ATP1-420-120-SP
Powered AC current transducer, jumper-selectable 0–10/20/50 A range, 4–20 mA output, 120 VAC/DC power supply, split-core case. (DIN rail adapters are included)



(1) Full Scale Range

0	2, 5 A
1	10, 20, 50 A
2	100, 150, 200 A

(2) Output Signal

005	0–5 VDC
010	0–10 VDC
420	4–20 mA

(3) Power Supply

120	120 VAC/DC
24U	24 VAC/DC with isolated output

(4) Case Style

FF	Solid-core
SP	Split-core

