

# DS1-FD SERIES

## AC or DC Current Relay

DS1-FD Current Relays monitor AC or DC loads: motor, crane, or welding equipment. The relay features a large aperture and solid-core design that allows for quick installation, just thread the conductor through the sensing window (aperture) and reconnect on the other side. The relay output is isolated from the monitored circuit and can switch up to two amps up to 125 VAC, or two amps to 30 VDC. The output contacts can reset to original condition on current fall or latch in the tripped condition. The trip point (where the output relay changes state) can be adjusted between 20 and 400 amps by adjusting two potentiometers. One provides a “coarse” adjustment; the second allows for fine tuning of the trip point. The sensor mounts on a back panel or a DIN rail, and is designed to accommodate wire sizes for loads up to 400 amps or higher. The maximum current is unlimited, so current higher than the highest adjustment point will keep the relay in the tripped condition.



### Current Relay Applications

#### Welding Processes

- Detect time of use using the normally open contact, which is closed with DC current over the trip point.

#### Under Current Detection

- If the power to the field of a shunt wound DC motor is lost, the speed will be uncontrollable. The normally closed contact will be open in normal operating conditions and closed to alarm if the field power is lost. Alternatively, the normally open contact could be closed during normal conditions and open the circuit to a contactor coil if the monitored circuit's current fell below the trip point.

#### DC Motors

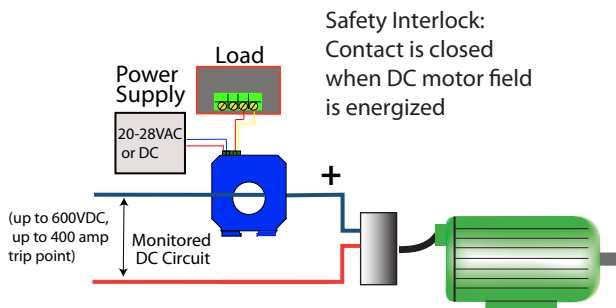

### Current Relay Features

#### Factory Calibrated and Warranted For Five Years

- Trip point to 400 ADC or 338 AAC.
- Sensor is not polarity sensitive with regard to the monitored circuit.
- Designed for longest life and reliability.

#### Single Pole, Double Throw Relay Output

- Can control an AC or DC circuit.
- Compatible with most automation and control systems.
- Both NO contact for alarm (closing on current rise) and NC contact (opening on current rise) for disconnecting applications.
- Automatic reset or latching output available.
- Dual potentiometers allow for accurate trip point adjustment.

#### Externally Powered

- Simple and reliable connection.

#### Solid-core Case

- Sensing window provides ample space for single or multiple conductors.

#### DIN Rail or Panel Mount

- Simply snap onto a DIN rail\* or attach with screws to a panel for secure mounting.

#### Designed for UL, CUL and CE Approval

- Accepted worldwide.

\*For information on the DIN rail accessories kit, see page 140.

OEMs

**Test & Evaluation Units for OEMs**

Free program expedites evaluation process. See page 3 for details.

Current Relay Dimensions

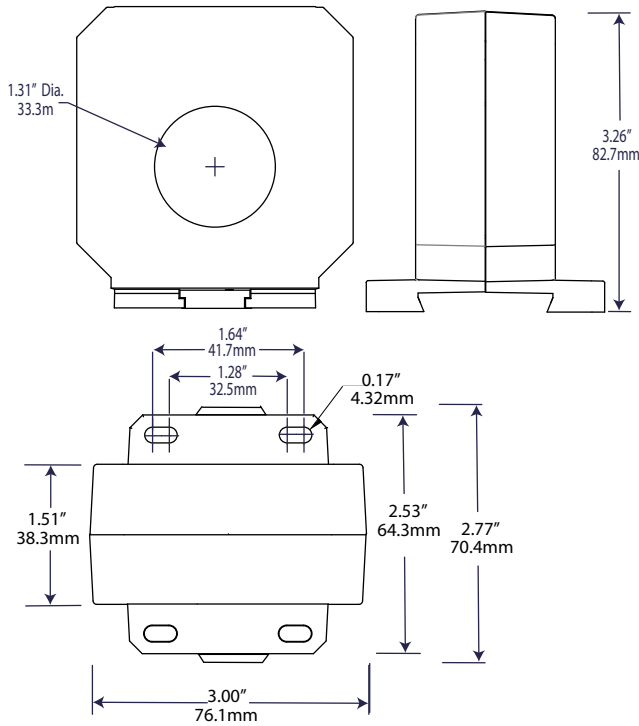

Current Relay Specifications

<b>Power Supply</b>	24U: 24 VAC/DC (20–28 V)
<b>Consumption</b>	<2 VA
<b>Output</b>	SPDT relay, 2 A @ 125 VAC, 2 A @ 30 VDC (max., general duty)
<b>Maximum Monitored Current</b>	>1000 ADC (unlimited)
<b>Response Time</b>	80 ms (max.) Hysteresis = 5%
<b>Range</b>	20–400 ADC (17–338 AAC 60 Hz)
<b>Dielectric Resistance</b>	Working voltage to 1500 VDC
<b>Frequency Range</b>	DC to 400 Hertz
<b>Case</b>	UL94 V0 Flammability Rated
<b>Environmental</b>	-4 to 122°F (-20 to 50°C) 0–95% RH, non-condensing
<b>Listings</b>	Designed for UL/cUL and CE approval

Current Relay Connections

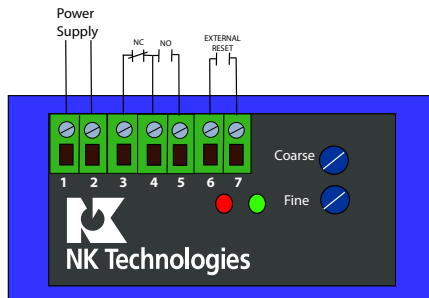

Latching

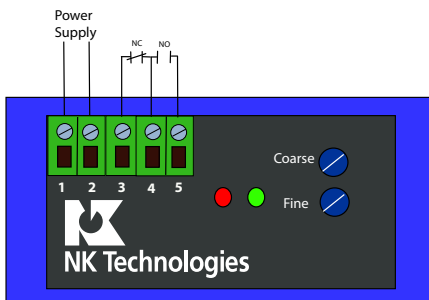

Auto Reset

Current Relay Ordering Information

Sample Model Number: DS1-SDTA-24U-FD  
DC current operated relay, 20–400 ADC adjustment range, SPDT relay output, 24 VAC/DC powered, panel or DIN rail mounting.



(1) Range

1	Adjustment range 20 to 400 ADC (17-338 AAC 60hz)
---	--

(2) Output

SDTA	Single Pole, double throw relay 2 A @ 120 VAC Auto Reset
SDTL	Single Pole, double throw relay 2 A @ 120 VAC Latching

(3) Power Supply

24U	24 VAC or DC externally powered
-----	---------------------------------

(4) Case Style

FD	Solid-core, DIN rail or panel mount
----	-------------------------------------

