

Specifications

Current Ranges	0-50 and 0-100 (See Model Number Key)
Output Signal	333mVDC, 0-5VDC or 0-10VDC
Power Supply	5.1 - 5.9 VDC (333mV output) 11.5 - 13.2 VDC (5 or 10V output)
Accuracy	1% FS
Output Polarity	Unipolar: Current one direction only
Frequency Range	DC
Isolation Voltage	3kV (Monitored line to output)
Linearity	0.75%
Response Time	400 mS (to 90% of step change)
Repeatability	1% FS
Power Consumption	<2 VA: $\frac{(\text{supply voltage}-5)}{100} + 0.05 +$ $(\text{supply voltage}) * (\text{output load current}) = \text{Total}$
Case	UL 94V-0 Flammability rated thermoplastic
Environmental	-20 to 50 ° C (for stated accuracy) 0-95% RH, non-condensing
Temperature Drift	<0.01% / ° C

Output Polarity

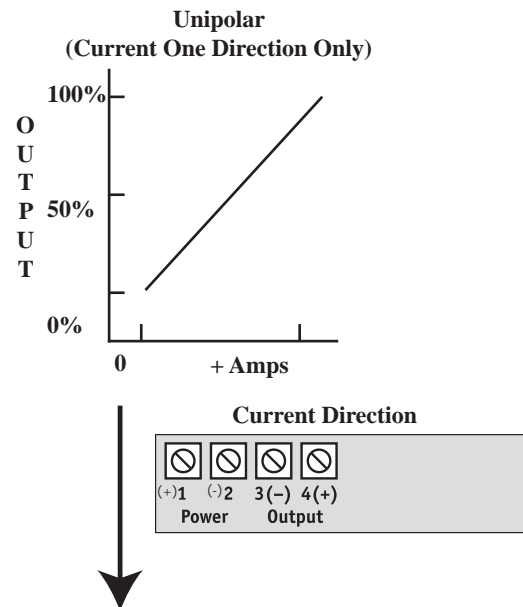

Model Number Key

DT	B	- 333	- 05D	- U	- SP
				CASE STYLE	
				SP- Split Core	
				OUTPUT POLARITY	
				U- Unipolar (One Direction)	
				POWER SUPPLY:	
				05D- 5 VDC (333mVDC only)	
				12D- 12 VDC (0.333, 5 and 10 VDC only)	
				OUTPUT:	
				333- 0-333 mVDC	
				005- 0-5 VDC	
				010- 0-10 VDC	
				RANGE	
				B 50A	
				C 100A	

SENSOR TYPE:

DT - DC current sensor with analog output

Know Your Power



Other NK Technologies Products Include:

DC Current Switches, Ground Fault Sensors
AC & DC Current Switches
Power Transducers
Current & Potential Transformers (CTs&PTs)



NK Technologies

3511 Charter Park Drive, San Jose, CA 95136
800-959-4014 or +1-408-871-7510 Phone
+1-408-871-7515 FAX
sales@nktechnologies.com, www.nktechnologies.com



INSTRUCTIONS



DT SERIES

**Temperature Compensated
333mVDC or 0-5/0-10VDC Output**

Quick "How To" Guide

1. Route wire to be monitored through aperture. Ensure current flow matches the arrow on sensor.
2. Mount the sensor to a surface if needed.
3. Connect output wiring.
 - A. Use up to 14 AWG copper wires. Tighten terminals to 4 inch-pounds torque.
 - B. For 333mVDC output models, make sure output load is 50 Ω or higher.
 - C. For 5 or 10VDC output models, make sure output load is at least 10K Ω.
4. Connect Power
 - A. Connect the appropriate power supply.
 - B. Observe polarity
 - C. Energize the power supply
5. Energize the monitored load.

Description

DT Series transducers combine a Hall Effect sensor and a signal conditioner into a single package. This provides higher accuracy, lower wiring costs, easier installation and saves valuable panel space. DT Series are available in split core with 333 mVDC, 0-5VDC or 0-10 VDC outputs.

The output is compensated for temperature changes, so the output remains accurate within temperature range.

The DT series sensors replace Current Shunts, which will change the output dramatically with temperature, along with the output being unstable until the current has been present for roughly one hour. Shunts must also be used with a signal conditioner to produce an output usable by most panel meters or controllers.

The DT sensors will be accurate and stable across the sensing range almost immediately.

Installation

For All Versions

Run wire to be monitored through opening in the sensor. Be sure the monitored current flows in the same direction as indicated by arrow on sensor. The arrow is just above the latch with the “+” symbol on the right and the “-” symbol on the left.

DT Series transducers work in the same environment as motors, contactors, heaters, pull-boxes, and other electrical enclosures. They can be mounted in any position or hung directly on wires with a wire tie. Just leave at least one inch distance between sensor and other magnetic devices.

Split-Core

Press the tab in the direction as shown to open the sensor. After placing the wire in the opening, press the hinged portion firmly downward until a definite click is heard and the tab pops out fully.

Output Wiring

Connect control or monitoring wires to the sensor. Use up to 14 AWG copper wire and tighten terminals to 4 inch-pounds torque.

0-333mVDC:

The signal is powered by the DT Transducer. Minimum impedance is 50 Ω .

0-5VDC & 0-10 VDC:

Signal is powered by the DT Transducer. Minimum output load (impedance) 10K Ω for the 5 or 10 volt models.

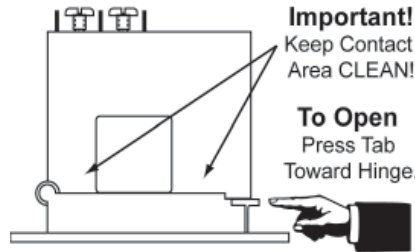

50 Ω minimum for 333 mVDC output
10K Ω for 5 or 10 VDC output
Check impedance of the controller or panel meter

5-6VDC Power for 333 mVDC output
11.5-13.2 VDC Power for 5 or 10 VDC output

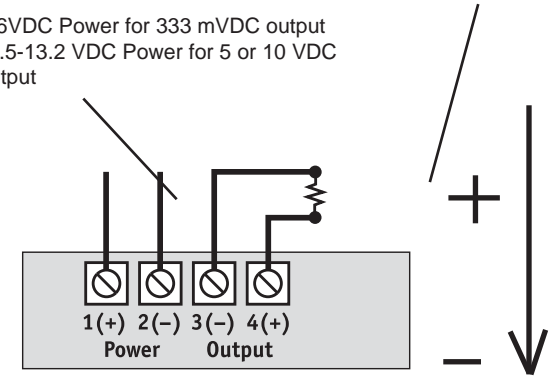

KEEP SPLIT-CORE SENSORS CLEAN.

Silicone grease is factory applied on the mating surfaces to prevent rust and improve performance. Be careful not to allow grit or dirt onto the grease in the contact area. Operation can be impaired if the mating surfaces do not have good contact. Check visually before closing.

Trouble Shooting - All Models

1. Output Signal Too Low

- Power supply is inadequate. *Check power supply. Make sure it is of sufficient voltage with all loads at maximum. DT Series draw less than 2.0 VA.*
- Output load too low. *Check output load, be sure it is at least 50 Ω for 333mVDC models, 10K Ω for 5VDC or 10 VDC signals.*

2. Output Signal is always at maximum

- The model selected may be calibrated for a current range that is too low for current being monitored. *Select a sensor with a higher range.*

3. Sensor has no output

- Polarity is not properly matched. *Check and correct wiring polarity*
- Monitored load is not DC or is not on. *Check that the monitored load is DC and that it is actually on.*
- Split Core models: The core contact area may be dirty. *Open the sensor and clean the contact area.*

4. Output does not correspond properly with current measured with a test meter:

- Possibly the monitored load is not purely DC. The sensor will be accurate only if the load is DC. *Check the primary circuit using an oscilloscope. If there is an AC component or the wave shape is pulsed, please contact the factory for possible other alternatives.*



Call Us 1.877.571.7901