

Ultimus IV Series Dispensers

Operating Manual



Electronic pdf files of Nordson EFD manuals are also available at www.nordsonefd.com



You have selected a reliable, high-quality dispensing system from Nordson EFD, the world leader in fluid dispensing. The Ultimus™ IV fluid dispenser was designed specifically for industrial dispensing and will provide you with years of trouble-free, productive service.

This manual will help you maximize the usefulness of your Ultimus IV dispenser.

Please spend a few minutes to become familiar with the controls and features. Follow our recommended testing procedures. Review the helpful information we have included, which is based on more than 50 years of industrial dispensing experience.

Most questions you will have are answered in this manual. However, if you need assistance, please do not hesitate to contact EFD or your authorized EFD distributor. Detailed contact information is provided on the last page of this document.

The Nordson EFD Pledge

Thank You!

You have just purchased the world's finest precision dispensing equipment.

I want you to know that all of us at Nordson EFD value your business and will do everything in our power to make you a satisfied customer.

If at any time you are not fully satisfied with our equipment or the support provided by your Nordson EFD Product Application Specialist, please contact me personally at 800.556.3484 (US), 401.431.7000 (outside US), or Tara.Tereso@nordsonefd.com.

I guarantee that we will resolve any problems to your satisfaction.

Thanks again for choosing Nordson EFD.

A stylized, handwritten signature of Tara Tereso in black ink.

Tara Tereso, Vice President

Contents

Contents	3
Introduction	4
Nordson EFD Product Safety Statement	5
Halogenated Hydrocarbon Solvent Hazards	6
High Pressure Fluids	6
Qualified Personnel	6
Intended Use	7
Regulations and Approvals	7
Personal Safety	7
Fire Safety	8
Preventive Maintenance	8
Important Disposable Component Safety Information	9
Action in the Event of a Malfunction	9
Disposal	9
Specifications	10
First Steps	11
Features & Controls: Front Panel	12
Manual / Programmed Dispense Select	12
Cycle Start	12
Program Number	13
Barrel Select	13
Reset	13
Home (F1)	14
Jog (F2)	14
Shot Count / Deposit Volume (F3)	15
Reset Shot Count (F4)	15
Deposit Volume / Forward	16
Pause	16
Pullback / Back	17
Manual Dispense Rate	18
Increase and Decrease	18
Features & Controls: Back Panel	19
Attaching the Syringe Barrel	20
Attaching the Barrel / Purging the Tip	20
Removing the Syringe Barrel	20
Program Function	21
How to Make a Bead	22
Modify Function	23
Operating Tips	24
Pre-Load Adjustment	25
Syringe Barrel Filling	26
Input / Output Connection	27
Voltage Initiate Circuit	27
Mechanical Contact Initiate	27
End-of-Cycle Feedback Circuit	27
Pin Function	27
Part Numbers	28
Accessories	28
Components	29
Replacement Parts	29
Troubleshooting	30

Introduction

The Ultimus IV Dispensing System is designed to provide complete process control using a patented positive displacement technology.

There are four core variables to the system: Deposit Volume, Dispense Rate, Pause, and Pullback.

To achieve the ideal deposit size, adjust only one of these variables at a time, in small increments. Key features include:

- Repeatable, precise fluid control
- All electric; no requirement for compressed air
- Programmable Pullback to eliminate oozing
- Menu-driven touch pad
- 100 user-defined memory cells for storing barrel size, deposit volume, dispense rate, pause, and pullback

The Ultimus IV Dispensing System provides consistent results, regardless of changes in fluid volume, viscosity, or temperature. It is ideal for use with 2-part epoxies and other fluids with changing viscosities, or where a specific flow rate is needed.

Nordson EFD Product Safety Statement

WARNING

The safety message that follows has a WARNING level hazard.
Failure to comply could result in death or serious injury.



ELECTRIC SHOCK

Risk of electric shock. Disconnect power before removing covers and / or disconnect, lock out, and tag switches before servicing electrical equipment. If you receive even a slight electrical shock, shut down all equipment immediately. Do not restart the equipment until the problem has been identified and corrected.

CAUTION

The safety messages that follow have a CAUTION level hazard.
Failure to comply may result in minor or moderate injury.



READ MANUAL

Read manual for proper use of this equipment. Follow all safety instructions. Task- and equipment-specific warnings, cautions, and instructions are included in equipment documentation where appropriate. Make sure these instructions and all other equipment documents are accessible to persons operating or servicing equipment.



MAXIMUM AIR PRESSURE

Unless otherwise noted in the product manual, the maximum air input pressure is 7.0 bar (100 psi). Excessive air input pressure may damage the equipment. Air input pressure is intended to be applied through an external air pressure regulator rated for 0 to 7.0 bar (0 to 100 psi).



RELEASE PRESSURE

Release hydraulic and pneumatic pressure before opening, adjusting, or servicing pressurized systems or components.



BURNS

Hot surfaces! Avoid contact with the hot metal surfaces of heated components. If contact can not be avoided, wear heat-protective gloves and clothing when working around heated equipment. Failure to avoid contact with hot metal surfaces can result in personal injury.

Nordson EFD Product Safety Statement (continued)

Halogenated Hydrocarbon Solvent Hazards

Do not use halogenated hydrocarbon solvents in a pressurized system that contains aluminum components. Under pressure, these solvents can react with aluminum and explode, causing injury, death, or property damage. Halogenated hydrocarbon solvents contain one or more of the following elements.

Element	Symbol	Prefix
Fluorine	F	“Fluoro-”
Chlorine	Cl	“Chloro-”
Bromine	Br	“Bromo-”
Iodine	I	“Iodo-”

Check the Safety Data Sheet (SDS) or contact your material supplier for more information. If you must use halogenated hydrocarbon solvents, contact your EFD representative for compatible EFD components.

High Pressure Fluids

High pressure fluids, unless they are safely contained, are extremely hazardous. Always release fluid pressure before adjusting or servicing high pressure equipment. A jet of high pressure fluid can cut like a knife and cause serious bodily injury, amputation, or death. Fluids penetrating the skin can also cause toxic poisoning.

WARNING

Any injury caused by high pressure liquid can be serious. If you are injured or even suspect an injury:

- Go to an emergency room immediately.
- Tell the doctor that you suspect an injection injury.
- Show the doctor the following note.
- Tell the doctor what kind of material you were dispensing.

Medical Alert — Airless Spray Wounds: Note to Physician

Injection in the skin is a serious traumatic injury. It is important to treat the injury surgically as soon as possible. Do not delay treatment to research toxicity. Toxicity is a concern with some exotic coatings injected directly into the bloodstream.

Qualified Personnel

Equipment owners are responsible for making sure that EFD equipment is installed, operated, and serviced by qualified personnel. Qualified personnel are those employees or contractors who are trained to safely perform their assigned tasks. They are familiar with all relevant safety rules and regulations and are physically capable of performing their assigned tasks.

Nordson EFD Product Safety Statement (continued)

Intended Use

Use of EFD equipment in ways other than those described in the documentation supplied with the equipment may result in injury to persons or damage to property. Some examples of unintended use of equipment include:

- Using incompatible materials.
- Making unauthorized modifications.
- Removing or bypassing safety guards or interlocks.
- Using incompatible or damaged parts.
- Using unapproved auxiliary equipment.
- Operating equipment in excess of maximum ratings.
- Operating equipment in an explosive atmosphere.

Regulations and Approvals

Make sure all equipment is rated and approved for the environment in which it is used. Any approvals obtained for Nordson EFD equipment will be voided if instructions for installation, operation, and service are not followed. If the equipment is used in a manner not specified by Nordson EFD, the protection provided by the equipment may be impaired.

Personal Safety

To prevent injury, follow these instructions:

- Do not operate or service equipment unless you are qualified.
- Do not operate equipment unless safety guards, doors, and covers are intact and automatic interlocks are operating properly. Do not bypass or disarm any safety devices.
- Keep clear of moving equipment. Before adjusting or servicing moving equipment, shut off the power supply and wait until the equipment comes to a complete stop. Lock out power and secure the equipment to prevent unexpected movement.
- Make sure spray areas and other work areas are adequately ventilated.
- When using a syringe barrel, always keep the dispensing end of the tip pointing towards the work and away from the body or face. Store syringe barrels with the tip pointing down when they are not in use.
- Obtain and read the Safety Data Sheet (SDS) for all materials used. Follow the manufacturer's instructions for safe handling and use of materials and use recommended personal protection devices.
- Be aware of less-obvious dangers in the workplace that often cannot be completely eliminated, such as hot surfaces, sharp edges, energized electrical circuits, and moving parts that cannot be enclosed or otherwise guarded for practical reasons.
- Know where emergency stop buttons, shutoff valves, and fire extinguishers are located.
- Wear hearing protection to protect against hearing loss that can be caused by exposure to vacuum exhaust port noise over long periods of time.

Nordson EFD Product Safety Statement (continued)

Fire Safety

To prevent a fire or explosion, follow these instructions:

- Shut down all equipment immediately if you notice static sparking or arcing. Do not restart the equipment until the cause has been identified and corrected.
- Do not smoke, weld, grind, or use open flames where flammable materials are being used or stored.
- Do not heat materials to temperatures above those recommended by the manufacturer. Make sure heat monitoring and limiting devices are working properly.
- Provide adequate ventilation to prevent dangerous concentrations of volatile particles or vapors. Refer to local codes or the SDS for guidance.
- Do not disconnect live electrical circuits when working with flammable materials. Shut off power at a disconnect switch first to prevent sparking.
- Know where emergency stop buttons, shutoff valves, and fire extinguishers are located.

Preventive Maintenance

As part of maintaining continuous trouble-free use of this product, Nordson EFD recommends the following simple preventive maintenance checks:

- Periodically inspect tube-to-fitting connections for proper fit. Secure as necessary.
- Check tubing for cracks and contamination. Replace tubing as necessary.
- Check all wiring connections for looseness. Tighten as necessary.
- Clean: If a front panel requires cleaning, use a clean, soft, damp rag with a mild detergent cleaner. DO NOT USE strong solvents (MEK, acetone, THF, etc.) as they will damage the front panel material.
- Maintain: Use only a clean, dry air supply to the unit. The equipment does not require any other regular maintenance.
- Test: Verify the operation of features and the performance of equipment using the appropriate sections of this manual. Return faulty or defective units to Nordson EFD for replacement.
- Use only replacement parts that are designed for use with the original equipment. Contact your Nordson EFD representative for information and advice.

Nordson EFD Product Safety Statement (continued)

Important Disposable Component Safety Information

All Nordson EFD disposable components, including syringe barrels, cartridges, pistons, tip caps, end caps, and dispense tips, are precision engineered for one-time use. Attempting to clean and re-use components will compromise dispensing accuracy and may increase the risk of personal injury.

Always wear appropriate protective equipment and clothing suitable for your dispensing application and adhere to the following guidelines:

- Do not heat syringe barrels or cartridges to a temperature greater than 38° C (100° F).
- Dispose of components according to local regulations after one-time use.
- Do not clean components with strong solvents (MEK, acetone, THF, etc.).
- Clean cartridge retainer systems and barrel loaders with mild detergents only.
- To prevent fluid waste, use Nordson EFD SmoothFlow™ pistons.

Action in the Event of a Malfunction

If a system or any equipment in a system malfunctions, shut off the system immediately and perform the following steps:

1. Disconnect and lock out system electrical power. If using hydraulic and pneumatic shutoff valves, close and relieve pressure.
2. For Nordson EFD air-powered dispensers, remove the syringe barrel from the adapter assembly. For Nordson EFD electro-mechanical dispensers, slowly unscrew the barrel retainer and remove the barrel from the actuator.
3. Identify the reason for the malfunction and correct it before restarting the system.

Disposal

Dispose of equipment and materials used in operation and servicing according to local codes.

Specifications

NOTE: Specifications and technical details are subject to change without prior notification.

Item	Specification
Cabinet size	18.4W x 8.1H x 32.3D cm (7.25W x 3.18H x 12.73D")
Weight	3.7 kg (8.2 lb)
Flexible cable assembly length	1.8 m (6 ft) to end of handset
Flexible cable assembly weight	0.113 kg (4.0 oz)
Flexible cable assembly bend radius	7.62 cm (3.0")
Power adapter	AC input: 100–240 VAC (+/-10%), ~50/60H DC output: 24 VDC @ 2.5 Amp
Minimum dispense volume	0.1 microliters (with 3cc syringe barrel)
Cycle rate	Exceeds 20 cycles per minute
End-of-cycle feedback circuits	5–24 VDC, 100 mA maximum
Cycle initiate	Foot pedal, Cycle Start button, or 5–24 VDC signal
Drive motor	1.8° microstepping, 1,600 steps/rev
Control circuitry	CMOS microprocessor
Interface	Tactile keypad
Hydraulic fluid	Petroleum-based lubricant
Enclosure rating	NEMA 1
Approvals	CE, TUV, RoHS, WEEE, China RoHS
US Patent No.	6,575,331

RoHS标准相关声明 (China RoHS Hazardous Material Declaration)

产品名称 Part Name	有害物质及元素 Toxic or Hazardous Substances and Elements					
	铅 Lead (Pb)	汞 Mercury (Hg)	镉 Cadmium (Cd)	六价铬 Hexavalent Chromium (Cr6)	多溴联苯 Polybrominated Biphenyls (PBB)	多溴联苯醚 Polybrominated Diphenyl Ethers (PBDE)
外部接口 External Electrical Connectors	X	0	0	0	0	0
<p>0: 表示该产品所含有的危险成分或有害物质含量依照EIP-A, EIP-B, EIP-C的标准低于SJ/T11363-2006 限定要求。 Indicates that this toxic or hazardous substance contained in all the homogeneous materials for this part, according to EIP-A, EIP-B, EIP-C is below the limit requirement in SJ/T11363-2006.</p> <p>X: 表示该产品所含有的危险成分或有害物质含量依照EIP-A, EIP-B, EIP-C的标准高于SJ/T11363-2006 限定要求。 Indicates that this toxic or hazardous substance contained in all the homogeneous materials for this part, according to EIP-A, EIP-B, EIP-C is above the limit requirement in SJ/T11363-2006.</p>						

WEEE Directive



This equipment is regulated by the European Union under WEEE Directive (2012/19/EU). Refer to www.nordsonefd.com/WEEE for information about how to properly dispose of this equipment.

First Steps

1. Unpack the dispenser.
2. For step-by-step setup instructions, see the Ultimus IV Quick Start Guide.

The Ultimus IV Dispensing System uses a flexible hydraulic link to transfer linear force from the drive motor to the syringe barrel. The motor lead screw and drive shaft are also linked mechanically. This patented link allows the transfer of up to 200 pounds of force from the motor to the assembly fluid.

Once a dispense cycle is complete, a programmed mechanical pullback retracts the plunger attached to the Nordson EFD piston. The combined action of the plunger with the unit's Forward steps, programmed Pause function, and Pullback feature creates a consistent deposit and prevents fluid from oozing.

The bore and stroke of the syringe barrel are used to calculate deposit volume. For example, the inside diameter of a 5cc syringe barrel measures 1.27 cm. One step moves the plunger 0.00008 cm, resulting in 0.0001 cc of fluid being displaced. With a 3cc barrel, it takes two steps to displace the same amount of fluid.

Flexible cable assembly

The force of the stepper motor is transferred to the syringe barrel by a flexible cable assembly.

The plunger, attached at the end of the cable, drives into the Nordson EFD piston inside the syringe barrel. This action forces the fluid out to make the deposit.

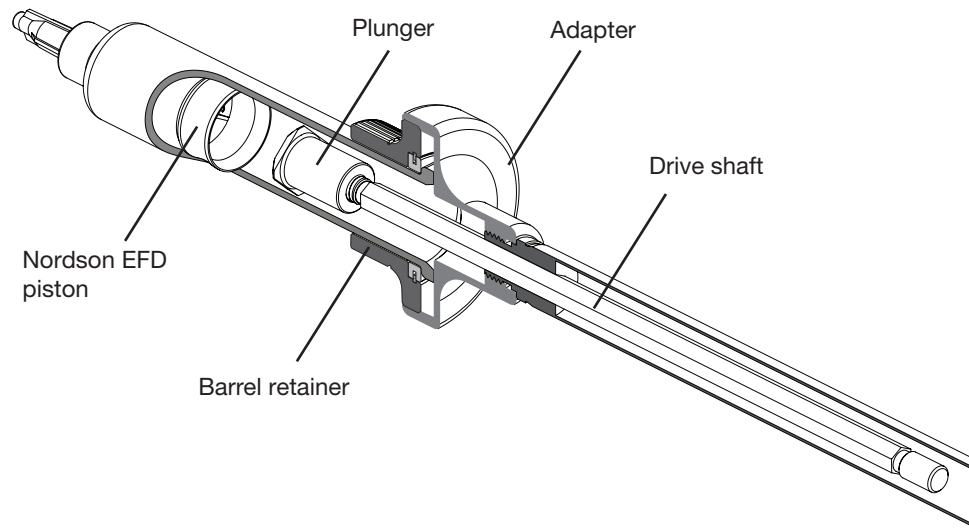

Power Input Receptacle

The Ultimus IV features a universal power supply. It automatically adjusts for input voltages ranging from 100 VAC to 240 VAC. There is no adjustment required by the user.

Features & Controls: Front Panel

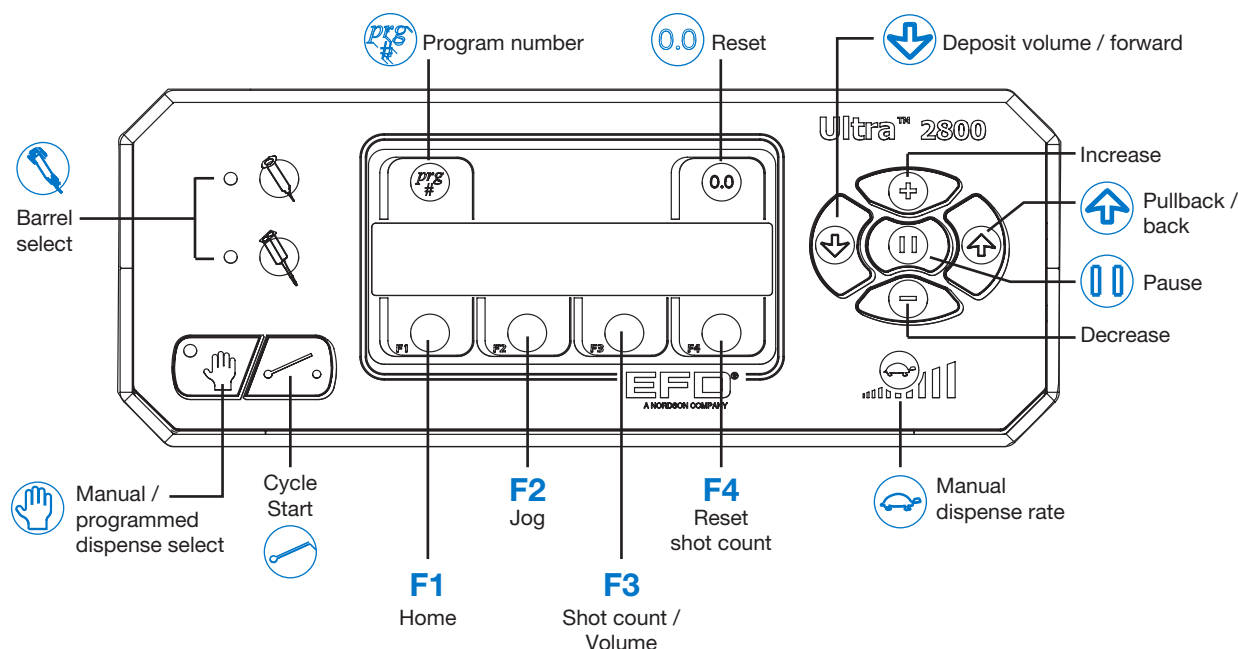

Manual / Programmed Dispense Select



Each mode allows you to access different features on the menu-driven display. Press the “hand” icon to change from MANUAL mode to PROGRAMMED DISPENSE mode.

- In MANUAL mode, you can use the foot pedal to dispense a continuous bead of fluid. You are in MANUAL mode when the red light next to the “hand” icon is on.
- In PROGRAMMED DISPENSE mode, you can set several variables, including Program Number, Syringe Barrel Size, Deposit Volume, Dispense Rate, Pause, and Pullback. You can also use the foot pedal or the Cycle Start button to dispense a single dot of fluid. You are in PROGRAMMED DISPENSE mode when the light next to the “hand” icon is off.

Cycle Start



The Cycle Start button serves the same purpose as the foot pedal.

Cycle Start in PROGRAMMED DISPENSE Mode

- In PROGRAMMED DISPENSE mode, pressing the Cycle Start button once will return you to the Home screen. Pressing it a second time will dispense a single deposit.

NOTE: Pressing the Cycle Start button accidentally while already in a dispense cycle can abort your program. Therefore, we recommend that you use the foot pedal (instead of Cycle Start) to activate the dispense cycle.

Cycle Start in MANUAL Mode

- In Manual mode, pressing the Cycle Start button once cancels the Manual selection and returns you to Programmed Dispense mode and the Home screen.

Features & Controls: Front Panel (continued)

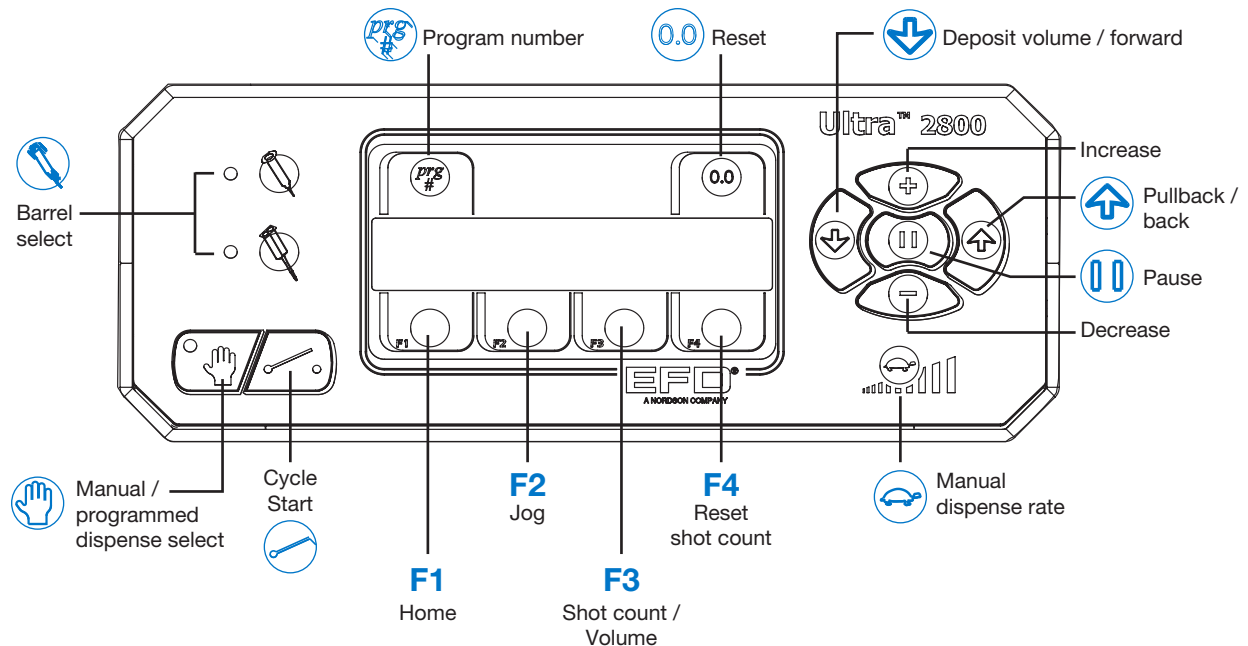

Program Number



In both PROGRAMMED DISPENSE and MANUAL mode, select the Program Number by pressing the prg button. The Program Number will flash. Use the (+) or (-) buttons to change or select the Program Number as needed. For more details, see the Program Function section on page 21.

Barrel Select



In both PROGRAMMED DISPENSE and MANUAL mode, pressing the top Single Barrel Select button activates the screen for the barrel size menu and pre-set dispense rates.

- Press the F1 button to set the barrel size. Use the (+) or (-) buttons to scroll through the various size options.
- Press the F3 button to set the Dispense Rate. Select Low, Medium, or High.

The dual barrel select button is not active.

Reset



In PROGRAMMED DISPENSE mode, press the Reset button to reset a range of variables, depending on the screen selected. Reset choices include syringe barrel volume level to 100%, Dispense Volume to 0 cc, Pause to 0 ms, Pullback to 0 steps, and Dispense Rate to the lowest minimum value possible, depending on the selected syringe barrel size.

NOTE: To reset Shot Count, use the F4 button.

In MANUAL mode, the Reset button is not active.

Features & Controls: Front Panel (continued)

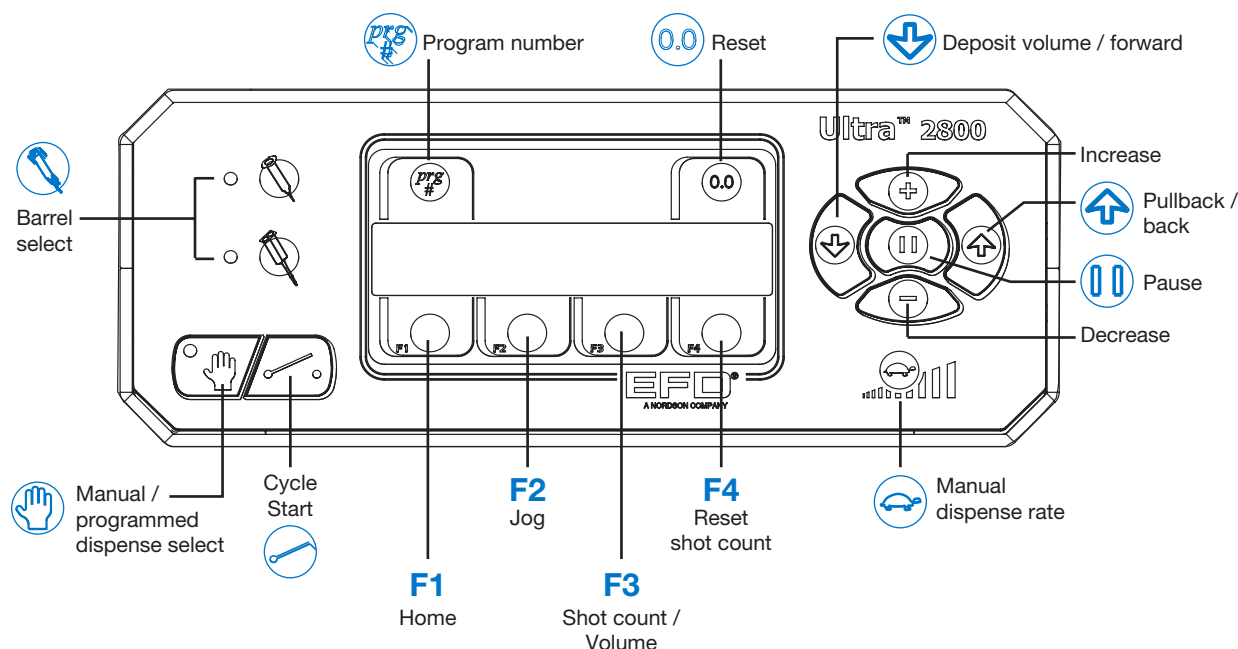

Home (F1)

In both PROGRAMMED DISPENSE and MANUAL mode, pressing the F1 button activates the “Retract to Home” screen. This step is required to remove the syringe barrel and / or when you want to prepare the unit for storage or shipping.

- Choose Yes by pressing the F3 button. This will fully retract the plunger.
- Choose No by pressing the F4 button. This will return you to the Home screen.

Jog (F2)

In PROGRAMMED DISPENSE mode, pressing the F2 button activates the Jog screen. Jog allows you to make small adjustments to the position of the plunger as it extends forward. Press and hold F2 until the “g” of Jog is highlighted. Use the FORWARD and BACK buttons to move the plunger slightly in either direction as needed.

In MANUAL mode, the F2 button is not active.

Features & Controls: Front Panel (continued)

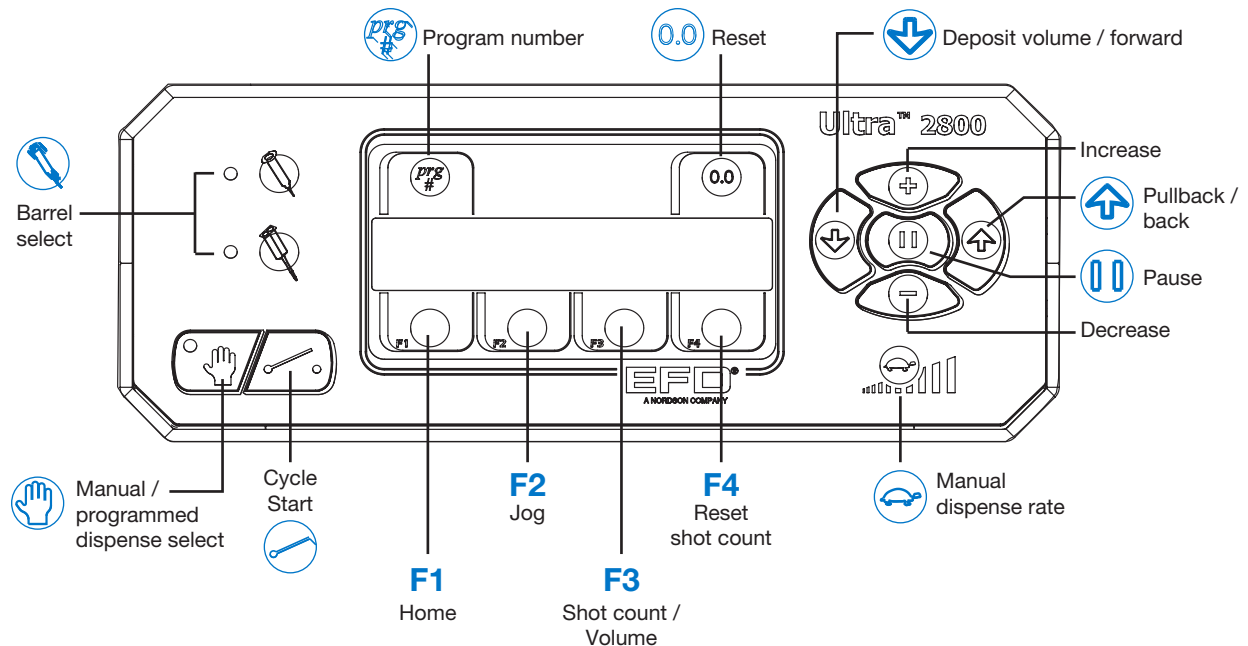

Shot Count / Deposit Volume (F3)

In PROGRAMMED DISPENSE mode, pressing the F3 button lets you toggle between Shot Count and Deposit Volume.

- Shot Count displays and tracks the number of deposit cycles. You can reset the Shot Count display to 0 by pressing the F4 button.
- Deposit Volume displays the current volume programmed in cc's.

In MANUAL mode, the F3 button is not active.

Other F3 commands:

- From the Retract to Home screen, F3 allows you to select the Yes option.
- After you press the Barrel Select button, F3 allows you to set the Dispense Rate.
- From the Modify screen, F3 allows you to adjust the syringe barrel specification for diameter. (See Modify Function, page 23.)

Reset Shot Count (F4)

In both PROGRAMMED DISPENSE and MANUAL mode, the F4 button is not active until you are in the screens noted below.

- From the Shot Count screen (F3), the F4 button allows you to reset the Shot Count to 0.
- From the Retract to Home screen (F1), F4 allows you to select the No option.
- From the Modify screen, F4 allows you to adjust the syringe barrel specifications for stroke. (See See Modify Function, page 23.)

Features & Controls: Front Panel (continued)

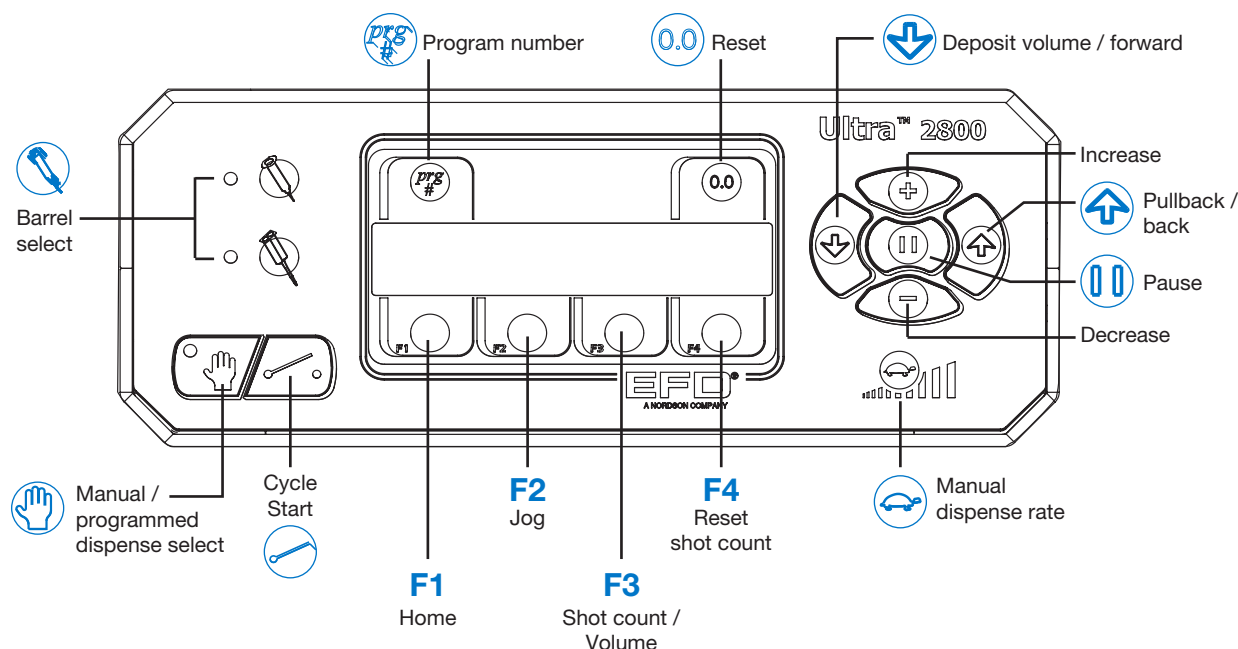

Deposit Volume / Forward



In PROGRAMMED DISPENSE mode, press the Forward button to activate the Deposit Volume screen. Use the (+) or (-) buttons to change the deposit volume as needed.

Deposit volume, measured in cc's, is automatically linked to Forward steps in the Ultimus IV stepper motor. When you increase the cc setting, it automatically increases the number of Forward steps. The maximum number of Forward steps is 65,534.

Deposit Volume is displayed when you press the F3 / Shot Volume button.

In MANUAL mode, pressing and holding the Forward button will extend the plunger from the cable assembly.

Pause



The Pause function "pauses" the action of the plunger during a dispense cycle, acts as a settling period, and allows the relief of back pressure between Forward and Pullback steps. Pause is helpful when you are dispensing a large amount of material with a very small tip. In most cases you will not need to use the Pause function.

In PROGRAMMED DISPENSE mode, press the Pause button to insert an end-of-cycle pause. Use the (+) or (-) buttons to set the Pause time.

In MANUAL mode, the Pause button is not active.

- Pause is measured in milliseconds. The maximum Pause is 60,000 ms (one minute).
- The default setting for Pause is 0 ms.

Features & Controls: Front Panel (continued)

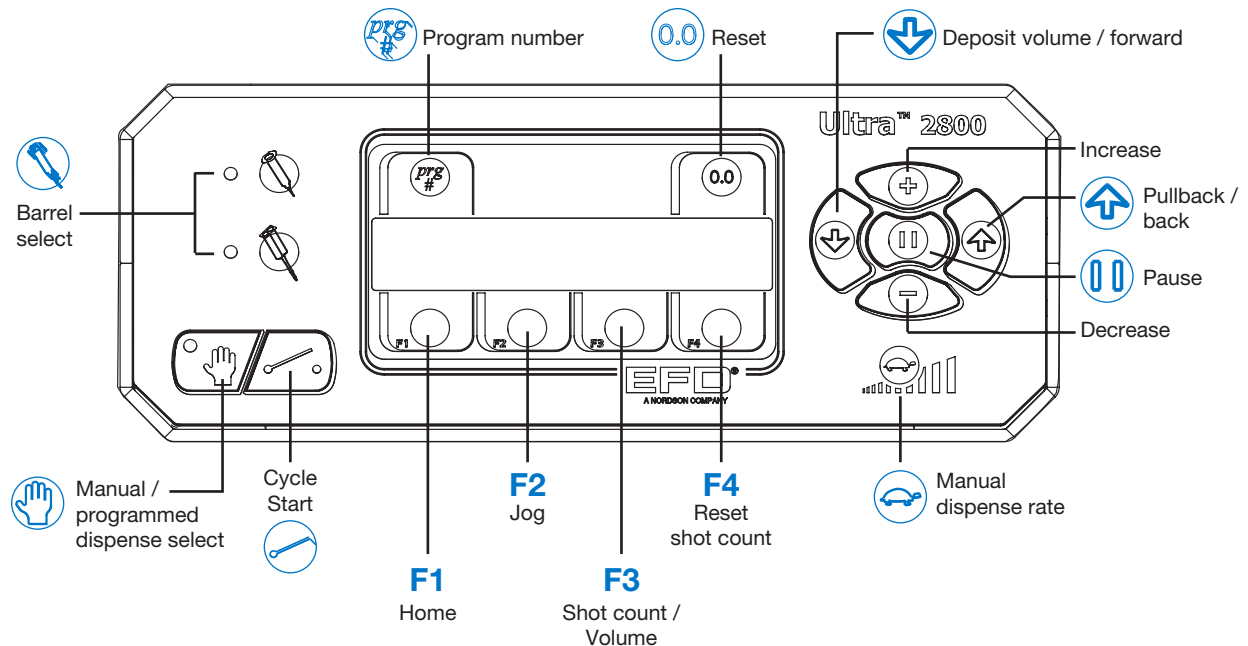

Pullback / Back



Pullback sets the number of steps that the plunger will retract into the cable assembly in preparation for the next dispense cycle. Be conservative when setting the Pullback. With thick fluids, too much Pullback can disengage the plunger from the piston. With thin fluids, excess Pullback can introduce air into the syringe barrel.

In PROGRAMMED DISPENSE mode, press the Back button to activate the Pullback screen. Use the (+) or (-) buttons to change the number of Pullback steps as needed.

- Use Pullback to eliminate dripping and oozing. We recommend a minimum Pullback of 200 steps for low viscosity fluids.
- For thicker fluids, set the Pullback to 300 steps or more.
- In general, adjust Pullback in small increments of 50 steps at a time for best results. Press the foot pedal to dispense, and visually check the deposit. Adjust Pullback again if necessary. When setup is correct, there should be no oozing or dripping.
- The maximum number of Pullback steps is 20,000.
- The default setting for Pullback is 200 steps.

In MANUAL mode, press and hold the Back button to manually retract the plunger as needed.

Features & Controls: Front Panel (continued)

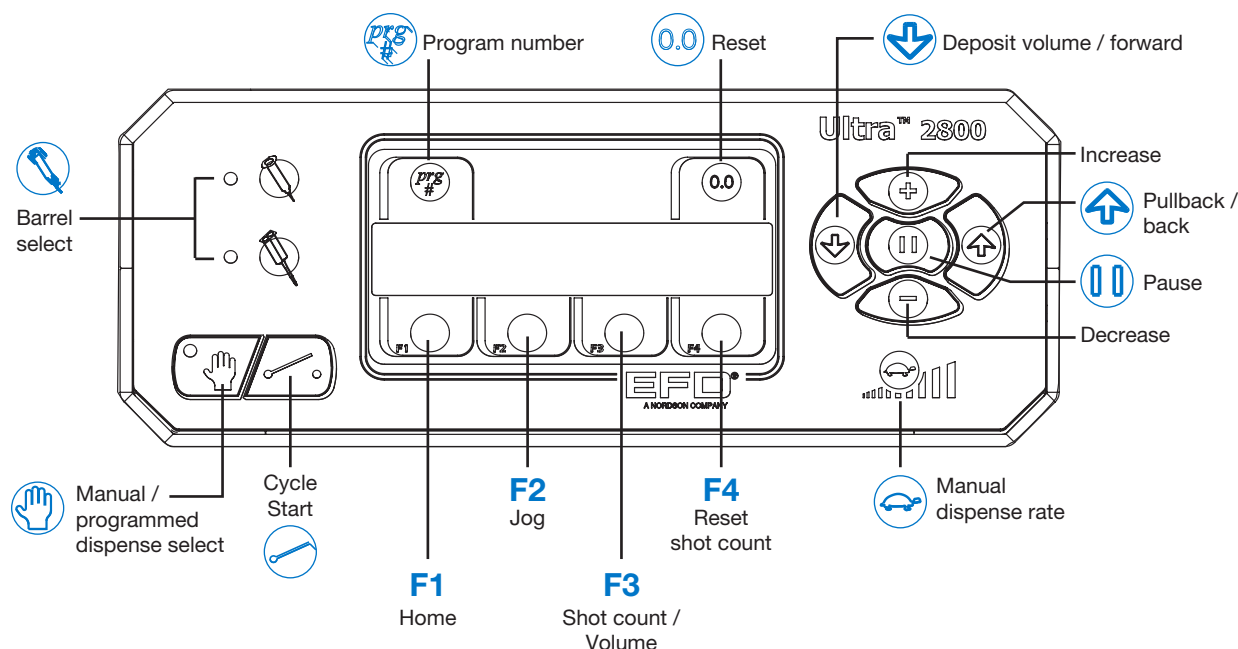

Manual Dispense Rate

In both PROGRAMMED DISPENSE and MANUAL mode, pressing the Turtle button allows you to manually set the Dispense Rate. Use the (+) or (-) buttons to change the speed manually if needed. In most cases, however, we recommend that you simply use one of the preset Dispense Rates.

1. Press the Single Barrel Select button.
2. Press F3 to access the Dispense Rate options.
3. Select Low, Medium or High.

Dispense Rate is based on cc's per second. For best results, use the slowest Dispense Rate practical for your application. In general, start with the preset default rate of Medium. Slower dispense rates give you better repeatability, since they create less fluid compression. This helps prevent oozing.

Increase and Decrease

In both PROGRAMMED DISPENSE and MANUAL mode, press the (+) or (-) button to change a number of variables, including Program Number, Deposit Volume, Dispense Rate, Pause milliseconds, Pullback steps, and more.

When the (+) or (-) buttons are pressed briefly, the settings will adjust slowly. When the (+) or (-) buttons are pressed and held, the settings will adjust faster.

Features & Controls: Back Panel

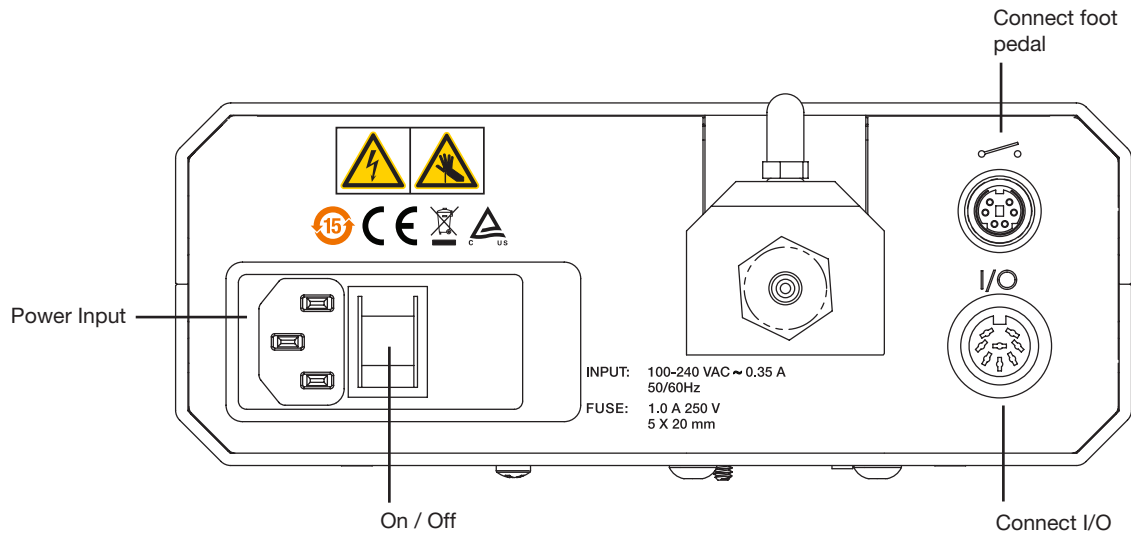

Attaching the Syringe Barrel

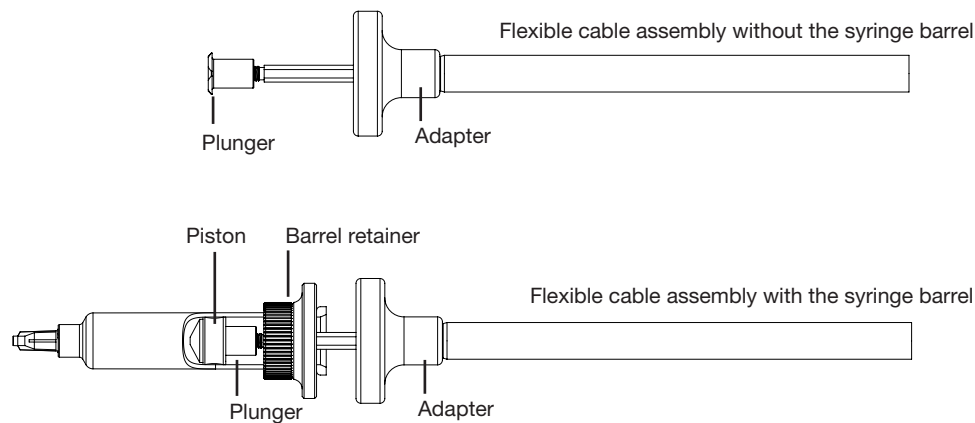

Attaching the Barrel / Purging the Tip

NOTE: Stay in MANUAL mode for all steps to attach the barrel.

1. Unscrew and remove the barrel retainer from the adapter.
2. Put a tip cap on the syringe barrel and hold barrel next to the flexible cable assembly.
3. From MANUAL mode (Hand icon light on), advance the plunger by pressing the Forward button, just until the plunger reaches past the piston.
4. By hand, insert the plunger into the barrel, pressing it snugly into the piston.

⚠ WARNING

When the plunger fits into the piston, stop pressing Forward. If you continue, excess pressure can build inside the barrel and may cause it to burst, resulting in serious injury.

5. Press the Pullback button to retract the barrel until there is just a small gap between the barrel and the adapter.
6. Slide the barrel retainer over the barrel and thread one turn onto the adapter.
7. Replace the tip cap with a dispense tip. Tighten the barrel retainer.
8. Still in MANUAL mode, press the foot pedal to purge the dispense tip. Press until fluid almost fills the tip and dispenses. Be sure not to overfill the tip since this results in excess back pressure, which can cause oozing.

NOTE: See the handout provided with your Ultimus IV dispenser, “Syringe Barrel Attachment Guide,” for simple, step-by-step instructions.

Removing the Syringe Barrel

1. Press F1 to open the Retract to Home screen. Select Yes. This will retract the plunger into the cable assembly.
2. Unscrew the barrel retainer from the adapter.
3. Slide the syringe barrel off the plunger.
4. Discard the barrel, or if storing for later use, replace the dispense tip with a tip cap.
5. Screw the barrel retainer back onto the adapter.

Program Function

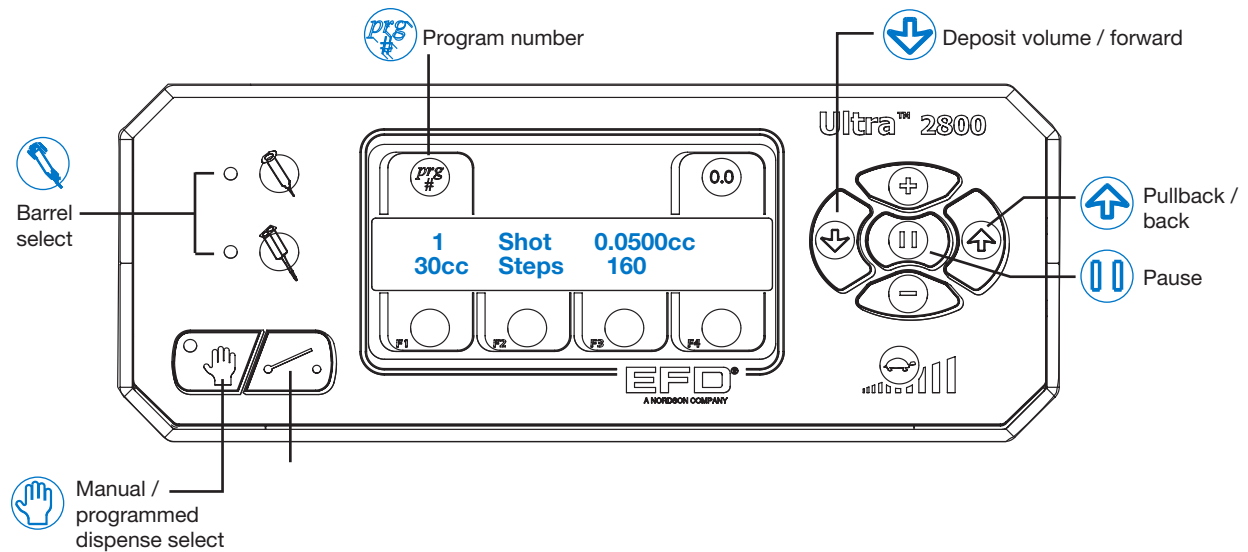

The Ultimus IV Dispensing System offers 100 user-defined memory programs, ranging from 0–99. The programs store the following information:

- Syringe barrel size
- Deposit volume
- Dispense rate
- Pause
- Pullback

Follow these steps to define a program:

1. Select PROGRAMMED DISPENSE mode. (Press “hand” icon so red light is off.)
2. Press prg to highlight the program number. Use the (+) or (-) buttons to assign or select the program number.
3. Press the icon for Single Barrel Select. Set the Dispense Rate from this screen by pressing F3 for Rate, then selecting Medium.
4. Select the Deposit Volume by pressing the FORWARD button. Use the (+) or (-) buttons to set the volume.
5. Select the Pullback by pressing the BACK button. Use the (+) or (-) buttons to set the Pullback.
6. Press the foot pedal once to return to the Home screen. The settings are automatically saved.
7. Press the foot pedal again to dispense the first deposit.

How to Make a Bead

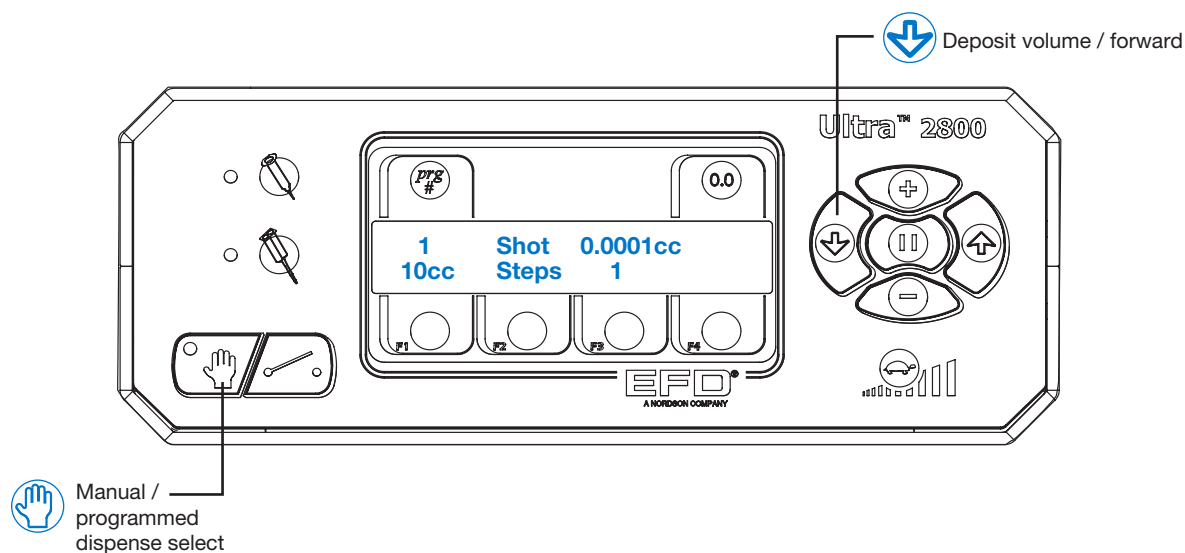

To deposit a continuous bead of fluid, instead of a single dot, follow these steps:

1. Select PROGRAMMED DISPENSE mode. (Press “hand” icon so red light is off.)
2. Press Forward and use (+) or (-) buttons to set the Dispense Volume to the lowest setting.
3. As a beginning point, keep Pause set to 0 ms and Pullback at 200 steps, then adjust as needed to eliminate drooling.
4. For best results, set the Dispense Rate to the preset of Lo to minimize back pressure in the syringe barrel. (Press Single Barrel Select button, then Rate, then Lo.)
5. Select MANUAL mode. (Press “hand” icon so red light is on.)
6. Press and hold the foot pedal until the required amount is dispensed.

NOTE: The Cycle Start button is not active in Manual mode, so use the foot pedal to activate the dispense cycle.

Modify Function

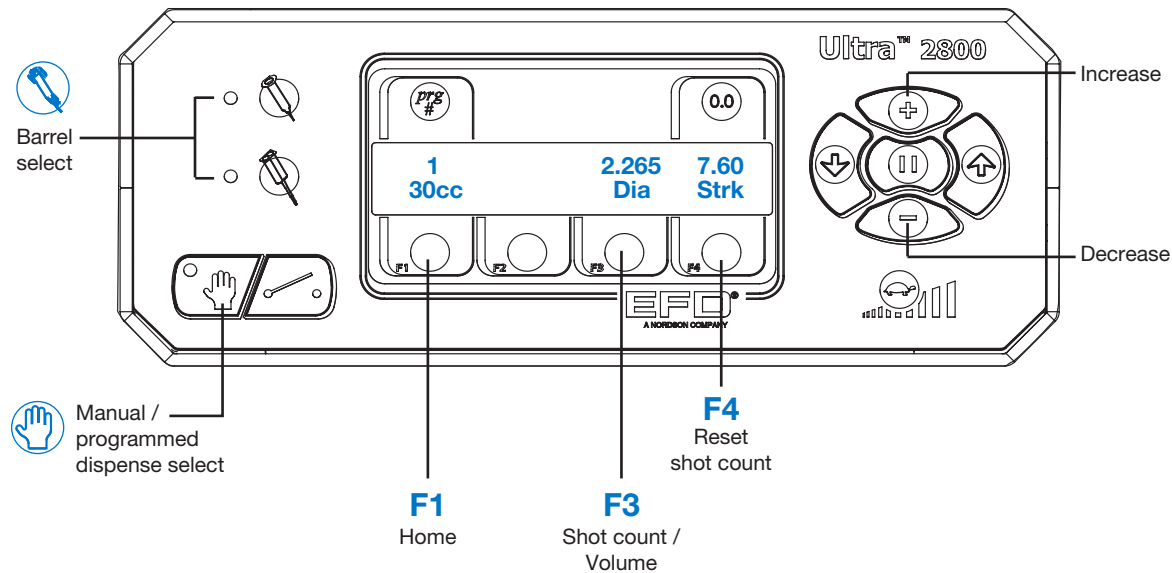

The Ultimus IV Dispensing System includes pre-set specifications based on industry-standard Nordson EFD syringe barrel dimensions. In most cases, you will want to use these pre-set specifications. However, you have the option to adjust the settings with the Modify function.

Follow these steps to use the Modify function:

1. From either the PROGRAMMED DISPENSE mode or the MANUAL mode, press the Single Barrel Select button. The MOD (Modify) option will appear.
2. If needed, press F1 to highlight the syringe barrel size. Use the (+) or (-) buttons to select the correct barrel size – for example, 3cc, 5cc, 10cc, or 30cc.
3. Press F4. This activates the Modify screen.
4. Press F3 to highlight the specifications for the diameter of the syringe barrel. This is displayed in centimeters. The settings will vary according to the syringe barrel size you have selected. Use the (+) or (-) buttons to adjust as needed.
5. Press F4 to highlight the specifications for the stroke of the syringe barrel, also listed in centimeters. Again, the settings will vary depending on the syringe barrel size you have selected. Use the (+) or (-) buttons to adjust as needed.

NOTE: The stroke should reflect the distance the Nordson EFD piston will travel to dispense all of the fluid in the syringe barrel. For example, if the barrel is loaded half-full, a certain stroke length (measured in centimeters) will be required to empty it. By adjusting the stroke for a specific barrel fill level, you will ensure that the “Level” display on the Home screen provides an accurate reading.

6. When finished, press the foot pedal once to return to the Home screen.

Operating Tips

Helpful Hints

- Faster dispense rates require more Pullback steps. That's because you are putting more pressure on the fluid, creating compression inside the syringe. For best results, use the preset default dispense rate of Medium.
- If you are making small deposits, you are likely creating a lot of pressure trying to force the fluid through a small dispense tip. Begin with the largest tip practical for your application, with a slow dispense rate. Depending on how thick your fluid is, you may also need to increase Pullback to relieve back pressure in the syringe barrel.
- Changing the dispense rate changes the deposit size. The Ultimus IV provides a metered deposit based on Forward steps at a specific dispense rate. When you change the dispense rate, the deposit size also changes, even though the number of Forward steps remains the same. For example, 25 Forward steps at the High dispense rate produces a smaller deposit than 25 Forward steps at the Low rate. That's because the slower rate gives the fluid more time to dispense, while the faster rate compresses the fluid and restricts the flow path. For optimum consistency, stay at the same dispense rate once you have stabilized your deposit settings.

Setting up the First Shot

- Go through the steps outlined in the Ultimus IV Quick Start Guide to establish your initial deposit. Work first with the EFD test material, included with your dispensing kit.
- Check the Ultimus IV Settings Grid for recommended settings, including Forward steps, Pause, Dispense Rate, and Pullback. The grid is included in your dispensing kit.
- Keep your Pullback setting low to reduce the risk of introducing air into your syringe barrel.
- Experiment with different values for each variable. Change only one value at a time and allow the deposit to stabilize before adjusting or changing another value.

Components

- Always use new Nordson EFD barrels and tips. Carefully dispose of after use. This procedure ensures maximum cleanliness, prevents contamination, and provides proper safety.
- You must use a piston with the Ultimus IV. Besides being required to connect with the plunger, the piston makes barrel loading, dispensing, and fluid handling cleaner, safer, and more accurate.
- Use the largest tip size possible. Smaller tips require more pressure, which can compress the fluid and cause oozing and more time. For best results when working with thick fluids, use EFD tapered tips. Tapered tips are specially designed to reduce the amount of pressure needed and are available in a range of sizes. They also help prevent drooling and oozing.

Cycle Start & Abort

The Cycle Start button serves the same purpose as the foot pedal. Pressing either of these once will return you to Home. However, pressing the Cycle Start button twice can abort your program. Therefore we recommend that you use the foot pedal to dispense from Programmed mode. A dispense cycle can be stopped at any time by pressing the Cycle Start button.

Pre-Load Adjustment

The pre-load on the cable within the flexible cable assembly is preset at the factory. However, over time the cable may stretch slightly, causing a change in performance. The pre-load adjustment block allows the user to make corrections to the pre-load due to cable stretch. If this happens, turn the pre-load plug clockwise to readjust the hex shaft to the 1/8" (3.2 mm) to 3/8" (9.5 mm) pre-load setting range. Do not exceed the 3/8" (9.5 mm) pre-load limit, as damage to the unit may result.

The pre-load adjustment block can compensate for approximately 1.5 cc of hydraulic fluid volume. However, only a small portion of this volume should ever need to be used. In addition, the pre-load typically needs to be adjusted just once during the early operation of the unit, and, depending on use, may never be required.

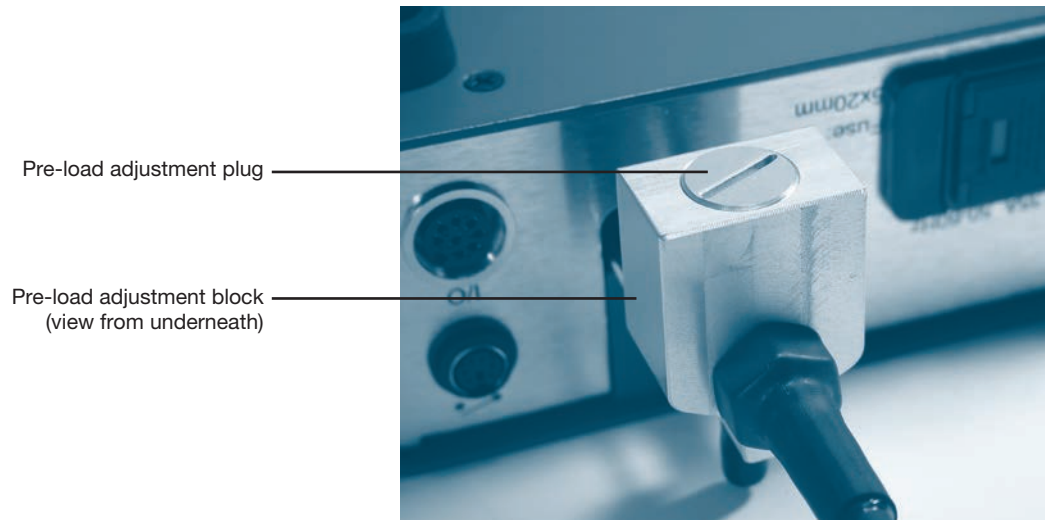

Follow these steps to make the adjustment:

1. Turn power off and detach the power cord.
2. Turn the unit over.
3. Use a slotted screwdriver to turn the plug clockwise.
4. Turn until the actuator extends to the 1/8" pre-load dimension, as shown in the figure below.

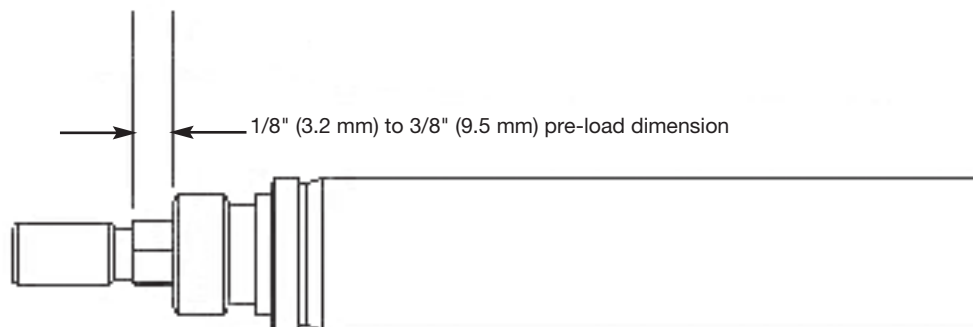

Syringe Barrel Filling

Avoid air in the syringe barrel:

Air in the fluid is a critical issue with the Ultimus IV Dispensing System. It can create problems with inconsistent deposits and drooling. For best results, use a Nordson EFD barrel filling station, or bottom-fill the syringe barrel. Simply insert the red piston and push it all the way inside the barrel, flush to the dispense tip. Then fill through the tip, pushing the piston down as the fluid enters. This prevents air from entering the syringe barrel.

If needed, eliminate air in the syringe barrel by using centrifuge or a vacuum chamber.

If the fluid being dispensed is pourable, attach a blue tip cap to the syringe barrel and pour the fluid in. Insert the piston and carefully press it down until it contacts the fluid. The syringe barrel is now ready for use.

If the fluid is thick or non-leveling, it can be spooned into the barrel with a spatula. Or, if the fluid comes packed in a 1/10 gallon cartridge, the barrel can be loaded with a caulking gun. After loading, press in the piston to move the fluid to the bottom of the barrel and to remove trapped air.

CAUTION

Do not completely fill syringe barrels. The optimum fill is a maximum 2/3 of the barrel capacity. If you are working with assembly fluids with a short pot life, you may want to fill to 1/2 of the syringe barrel.

Nordson EFD offers productive, air-free alternatives to traditional barrel loading methods. Here are a few suggestions that can help keep the work area clean, save time and reduce the chance of entrapped air in the fluid.

- The Nordson EFD Atlas Filling System (P/N 7022068) provides consistent filling for all types of nonpourable assembly fluids. It features built-in flow controls to prevent spillage and air entrapment.
- If you receive frozen epoxies or other fluids in medical type syringes with a manual plunger, request the Nordson EFD luer-to-luer fitting (P/N 7016862) to transfer the material from the original syringe to the Nordson EFD syringe barrel.
- Another option is the Nordson EFD Atlas Filling System (P/N 7022445). Pack the fluid into the 12ounce cartridge. Place the pre-filled cartridge into the barrel filler. Using air pressure, the barrel loader fills the syringe barrel (with piston) from the bottom up.
- If the fluid comes prepackaged in a 1/10 gallon (300 ml) caulking type cartridge, use the Nordson EFD Atlas Filling System.

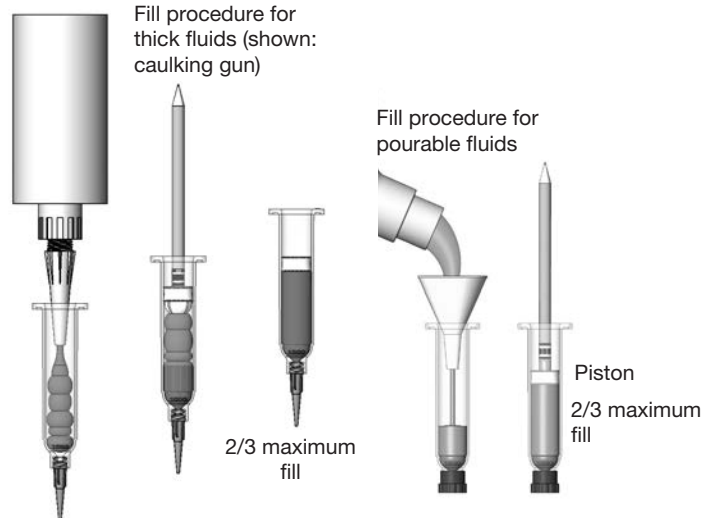

For additional assistance, contact a Nordson EFD Fluid Application Specialist.

Input / Output Connection

Voltage Initiate Circuit

The Ultimus IV workstation may be initiated with a 5 to 24 VDC signal across pins 1 and 2. These two input pins are current-driven and optically isolated. From the Programmed Dispense mode, this signal can be momentary (no less than 0.01 seconds) or maintained. In this mode, a new dispense cycle begins once the 5 to 24 VDC signal is removed and then applied again.

When this input circuit is activated in the Manual mode, a continuous bead is dispensed until the signal is removed.

Mechanical Contact Initiate

The Ultimus IV can be initiated via the closure of mechanical contacts, such as a relay or switch, using pins 7 and 8. The timing and actuation rules for the contact closure input are identical to the voltage initiate input description.

End-of-Cycle Feedback Circuit

Upon completion of a dispense cycle, a solid-state switch closes and remains closed until the next dispense cycle. This circuit is normally closed when a dispense cycle is not active. Pins 3 and 4 of this circuit can be used to signal back to a host computer, start another device in sequence, or initiate other operations that need to be tied into the completion of the dispense cycle.

The circuit is an optically isolated transistor output designed to operate between 5 to 24 VDC, 100 mA maximum.

Pin Function

1. Voltage initiate +, 5–24 VDC (22 mA at 24 VDC)
2. Voltage initiate -
3. End-of-cycle feedback output +, 5–24 VDC (100 mA maximum)
4. End-of-cycle feedback output -
5. 24 VDC supply + (100 mA maximum)
6. 24 VDC supply - (ground)
7. Contact closure +, 10 mA
8. Contact closure - (ground)

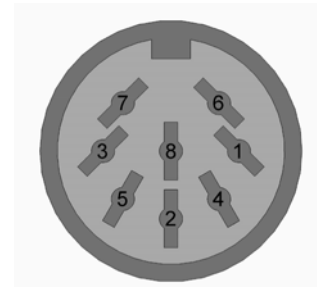

Back panel I/O pin diagram



NOTES:

- An 8-pin DIN connector and cable assembly is available. Order Nordson EFD P/N 7017143.
- Ultimus IV operation is identical for dispense initiation from I/O inputs or the foot pedal.
- Pins 6 and 8 of the I/O connector are internally connected to the signal ground.

Part Numbers

Part #	Description
7017178	Ultimus IV dispenser, 3cc syringe barrels
7017181	Ultimus IV dispenser, 5cc syringe barrels
7017177	Ultimus IV dispenser, 10cc syringe barrels
7017179	Ultimus IV dispenser, 30cc syringe barrels

Accessories

Item	Part #	Description	
	7017092	Omnidirectional foot pedal	Controls the dispense cycle
	7016718	Finger switch (rectangular connector)	Low voltage, push-button finger switch controls the dispense cycle
	7017089	Finger switch (round DIN connector)	
	7017143	8-pin I/O connector assembly	Allows easy connection to the dispenser for external control

Components

Retainers and Adapters

Part #	Description
7017210	3cc retainer
7017212	5cc retainer
7017209	10cc retainer
7017211	30cc retainer
7017183	3 / 5 / 10cc adapter
7017184	30cc adapter

Barrel / Piston (BP) Sets

Part #	Description
7014103	3cc BP kits, clear / red (50)
7012098	5cc BP kits, clear / red (40)
7012116	10cc BP kits, clear / red (30)
7012138	30 / 55cc BP kits, clear / red (20)
7012086	3cc BP kits LB / red (50)
7012104	5cc BP kits LB / red (40)
7012127	10cc BP kits LB / red (30)
7012146	30 / 55cc BP kits LB / red (20)

Pistons

Part #	Description
7360950	Optimum® plunger (all sizes)*
7012168	3cc red pistons (50)
7012174	5cc red pistons (40)
7012180	10cc red pistons (30)
7012186	30 / 55 / 70cc red pistons (20)
7014596	30 / 55 / 70cc yellow wiper pistons (20)

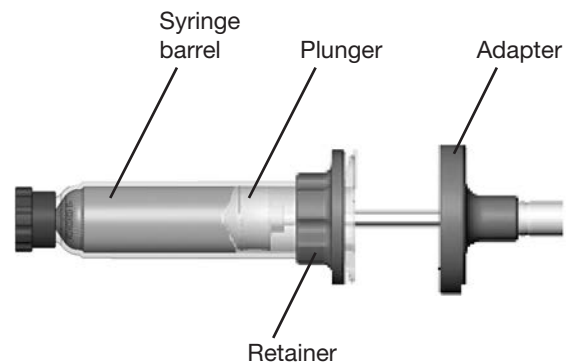

Replacement Parts

⚠ CAUTION

To accommodate smaller syringe barrels, Ultimus IV 3cc (P/N 7017178) and 5cc (P/N 7017181) systems use a stepped-down motor. Do not use 3cc or 5cc replacement parts or components with an Ultimus IV 10cc (P/N 7017177) or 30cc (P/N 7017179) system.

Part #	Description
7017208	Power supply kit
7017194	Motor drive kit
7017201	Front panel kit, 3cc / 5cc
7017200	Front panel kit, 10cc / 30cc
7017102	Replacement sleeve, 5 pk

Troubleshooting

If you encounter a problem that you cannot readily solve, call Nordson EFD.



Problem	Possible Cause and Correction
No power	<p>Check the fuses and replace as needed. Follow these steps:</p> <ol style="list-style-type: none"> 1. Disconnect the power to the unit prior to performing this service. 2. Locate the power entry module on the lower left corner of the rear panel. 3. If the electrical cord is still connected to the back of the unit, remove it now. 4. There is a small vertical slot just to the right of the red window on the power entry module. Insert a small screwdriver in the slot to pry the latch open. The door swings open to the left. 5. Pull out the red fuse tray. Note the location and orientation of the fuses. 6. Pull both fuses out of the fuse tray and discard. 7. Replace both with 1.0 A / 250 VAC, 5 x 20 mm fuses. Orient the fuses in the same manner as the fuses that were removed. 8. Insert the fuse tray back into the power module, close the fuse door, and reconnect power.
Blow by	<ul style="list-style-type: none"> • If you are dispensing a watery-thin fluid, request the Nordson EFD yellow wiper piston, available for the Ultimus IV 30cc Series model (P/N 7017179) only. Specify Nordson EFD part P/N 7022707.
Oozing	<ul style="list-style-type: none"> • There is too much fluid compression in the syringe barrel. Change to a fresh dispense tip and start over. If needed, switch to a slower dispense rate. • The plunger has become disengaged from the piston. To check, unscrew the retainer from the adapter and turn the syringe barrel upside down. If the syringe barrel falls off, the plunger is disengaged. See the handout, "Syringe Barrel Attachment Guide," for step-by-step instructions on how to properly engage the plunger and piston.
Inconsistent shot size	<ul style="list-style-type: none"> • There is air in the syringe barrel, either entering the barrel during filling, or from excessive Pullback. Eliminate air from the barrel, or adjust the Pullback. • The Dispense Rate may be too fast for the combination of fluid viscosity and dispense tip. Reduce the Dispense Rate. • The plunger is fouled. Remove the syringe and clean as needed. Also, check the dispensing tip, barrel, and material for possible clogging. For best results, change the dispense tip. • You may need to adjust the pre-load adjustment block. See page 25.
Dispense rate does not adjust	<ul style="list-style-type: none"> • If nothing seems to happen when you press the (+) or (-) button to manually adjust the Dispense Rate, the rate may already be set to a very low speed. Try switching to the preset default for Medium.
Service	<p>The interior mechanics of the Ultimus IV system are not field serviceable. Attempting to repair or service the unit by removing the enclosure cover voids the factory warranty. Please contact your Nordson EFD service representative for assistance.</p>

NORDSON EFD TWO YEAR LIMITED WARRANTY

This Nordson EFD product is warranted for two years from the date of purchase to be free from defects in material and workmanship (but not against damage caused by misuse, abrasion, corrosion, negligence, accident, faulty installation, or by dispensing material incompatible with equipment) when the equipment is installed and operated in accordance with factory recommendations and instructions.

Nordson EFD will repair or replace free of charge any defective part upon authorized return of the part prepaid to our factory during the warranty period. The only exceptions are those parts which normally wear and must be replaced routinely, such as, but not limited to, valve diaphragms, seals, valve heads, needles, and nozzles.

In no event shall any liability or obligation of Nordson EFD arising from this warranty exceed the purchase price of the equipment.

Before operation, the user shall determine the suitability of this product for its intended use, and the user assumes all risk and liability whatsoever in connection therewith. Nordson EFD makes no warranty of merchantability or fitness for a particular purpose. In no event shall Nordson EFD be liable for incidental or consequential damages.

This warranty is valid only when oil-free, clean, dry, filtered air is used, where applicable.



For Nordson EFD sales and service in over 40 countries, contact Nordson EFD or go to www.nordsonefd.com.

Global

800-556-3484; +1-401-431-7000
info@nordsonefd.com

Europe

00800 7001 7001
infoefd.europe@nordsonefd.com

Asia

China: +86 (21) 3866 9006; china@nordsonefd.com
India: +91 80 4021 3600; india@nordsonefd.com
Japan: +81 03 5762 2760; japan@nordsonefd.com
Korea: +82-31-736-8321; korea@nordsonefd.com
SEAsia: +65 6796 9522; sin-mal@nordsonefd.com

The Wave Design is a trademark of Nordson Corporation.
©2021 Nordson Corporation 7015539 v042821