

xQR41 Series MicroDot Needle Valve

Service & Replacement Parts Manual



IMPORTANT!
Save this Sheet.

Forward to
Maintenance or
Tool Crib Supervisors

Electronic pdf files of Nordson EFD
manuals are also available at
www.nordsonefd.com



Tools and Supplies

- Small pliers
- 0.035" hex wrench
- 1.5 mm hex wrench
- Nye gel lubricant
- Cleaning cloth
- Solvent

Valve Service Procedures

Follow these procedures to properly disassemble and reassemble the valve. Inspect, clean, and replace components as needed. Refer to “Replacement Parts” on page 7 for part numbers and for an exploded diagram of the valve components.

CAUTION

Before any component change or service activity, relieve air pressure from the fluid reservoirs.

CAUTION

To prevent damage, begin disassembly of the valve at the fluid outlet end.

Cleaning the Valve

Follow this procedure to thoroughly clean the fluid body and to replace the fluid body O-ring seal.

1. Turn the QR clasp thumbscrew **1** counterclockwise to disengage the clasp.
2. Carefully move the fluid body **2** downward until it clears the air cylinder / needle assembly.
3. If the fluid body O-ring seal (not shown) remains on the piston needle, gently slide it off the needle.

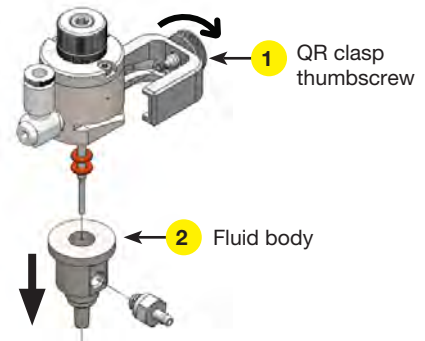

*Removing the fluid body
(valve with double-
stacked O-rings shown)*

Valve Service Procedures (continued)

Cleaning the Valve (continued)

CAUTION

Do not wipe the needle with an abrasive material, specifically in chemically sensitive applications. Doing so can damage the needle.

4. Clean the needle **3** with a cloth dampened in solvent.
5. Install a replacement double-stacked O-ring set **4** or spring-energized seal **5** on the needle.

NOTE: Lubricate double-stacked O-rings before installing. Use the supplied fluorocarbon grease only if the assembly fluid being dispensed is compatible with it.

NOTE: If a spring-energized seal is used, install the seal with the spring facing the fluid flow.

6. Reinstall the fluid body O-ring seal (not shown) on the needle.

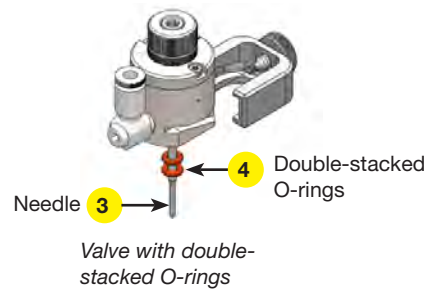

Correct orientation of a spring-energized seal

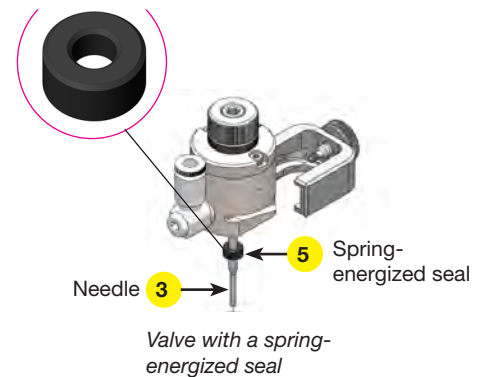

7. Use one hand to position the fluid body **2** on the air cylinder / needle assembly and then slide the QR clasp **6** into the grooves on the air cylinder body.

CAUTION

Do not over-tighten the QR clasp thumb screw. Doing so can break the screw.

8. Fully install the QR clasp as follows:
 - a. Partially thread the QR clasp thumbscrew into the air cylinder body.
 - b. When the thumbscrew is engaged, rotate the fluid body to the required alignment.
 - c. Finger-tighten the thumbscrew to fully secure fluid body to the air cylinder.

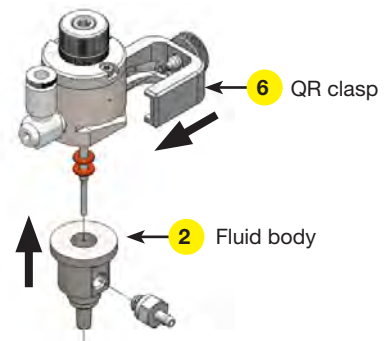

Valve Service Procedures (continued)

CAUTION

Before any component change or service activity, relieve air pressure from the fluid reservoirs.

Replacing the Piston and Needle Assembly or the Piston O-Ring

Follow this procedure to clean the air cylinder body and replace the piston O-ring.

1. **On adjustable cap valves only:**
 - a. Make a note of the current stroke setting number.
 - b. Turn the stroke control knob **1** counterclockwise one-half turn (or to fully open).
 2. Use a 1.5 mm hex wrench to remove the cap **2** (adjustable or non-adjustable).
 3. Remove the piston return spring **3**.
 4. Using small pliers, grasp the spring pilot of the piston and needle assembly **5** and then pull the assembly out of the air cylinder body.
- NOTE:** The piston and needle assembly is one unit and cannot be disassembled.
5. Remove the piston O-ring **4** from the piston and needle assembly.
 6. Clean the inside wall of the air cylinder body **7**.
 7. Lubricate the piston O-ring **4** with Nye Lubricant #865 gel and reinstall the O-ring.
 8. Reassemble the valve in the reverse order of disassembly, ensuring that the U-cup seal **6** is in place.
 9. **For adjustable cap valves only,** go to “Calibrating the Stroke” on page 5 to calibrate the stroke control.

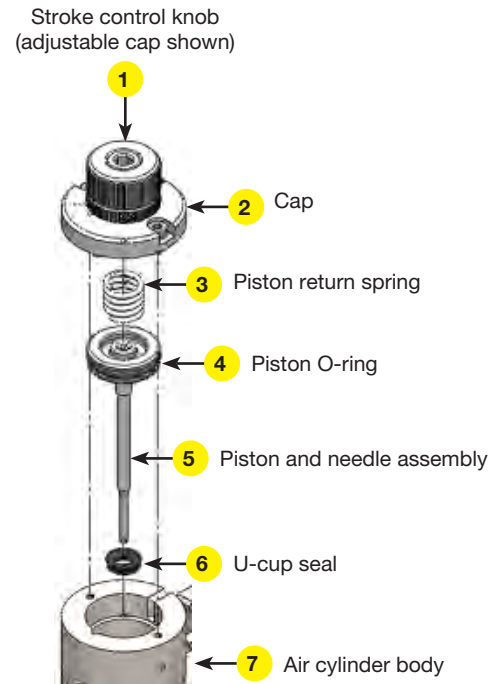

Valve Service Procedures (continued)

CAUTION

Before any component change or service activity, relieve air pressure from the fluid reservoirs.

Calibrating the Stroke

CAUTION

Do not over-tighten the stroke control knob. Tightening the knob past 2.6 N•m (20 in.-lb) of torque can damage the knob.

1. Make a note of the current stroke setting number.
2. Turn the stroke control knob clockwise **2** until it stops (at the internal piston).
3. If necessary, use a 0.035" hex wrench to re-zero the reference ring **4** by aligning the zero mark with the reference mark **1** on the air cylinder body.
4. Tighten the set screw **3** to lock the stroke reference ring in position.
5. Reset the stroke number setting to the position noted in step 1.

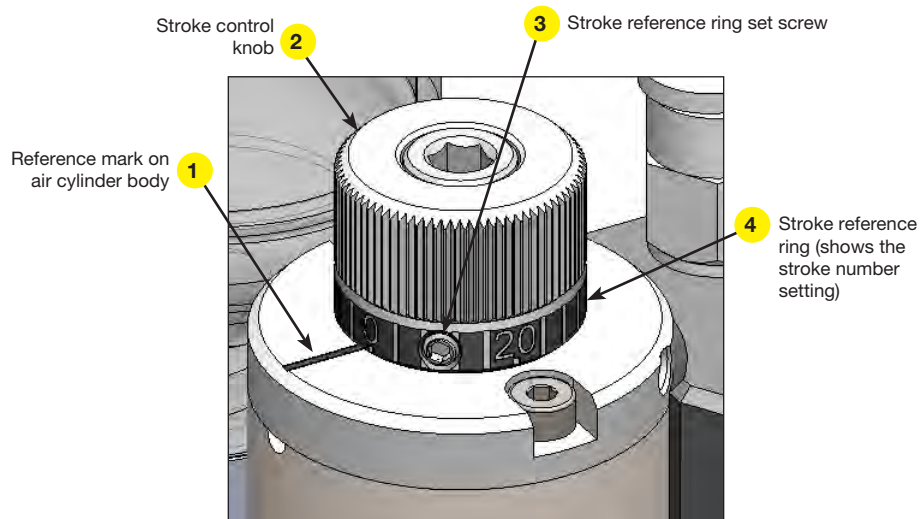

Valve Service Procedures (continued)

⚠ CAUTION

Before any component change or service activity, relieve air pressure from the fluid reservoirs.

⚠ CAUTION

Do not fully remove the mounting screw from the valve actuator housing. Be careful not to lose the Backpack mounting O-ring that is located between the Backpack and the xQR41 air cylinder body.

Replacing the Bullet Solenoid on the Backpack Valve Actuator

- Loosen the housing / mounting bolt **4** to release the Backpack valve actuator from the xQR41 valve air cylinder body.
NOTE: Ensure that the air inlet O-ring (not shown) between the Backpack actuator and the air cylinder body remains in place on the air cylinder body.
- Remove the spiral wrap (if used) around the Backpack valve actuator wires and air hose.
- Disconnect the air line.
- Unthread the cable connector **1** from the bullet solenoid.
- Engage the wrench flats on the bullet solenoid **2** and rotate it counterclockwise. When the bullet solenoid is loose, pull up on the solenoid to release it.
- Install a replacement bullet solenoid by rotating the solenoid clockwise until it is fully tightened.
- Use the housing / mounting bolt to reinstall the Backpack valve actuator **3** on the air cylinder body, ensuring that the air inlet O-ring is in place.
- Reconnect the bullet solenoid cable connector and air line.

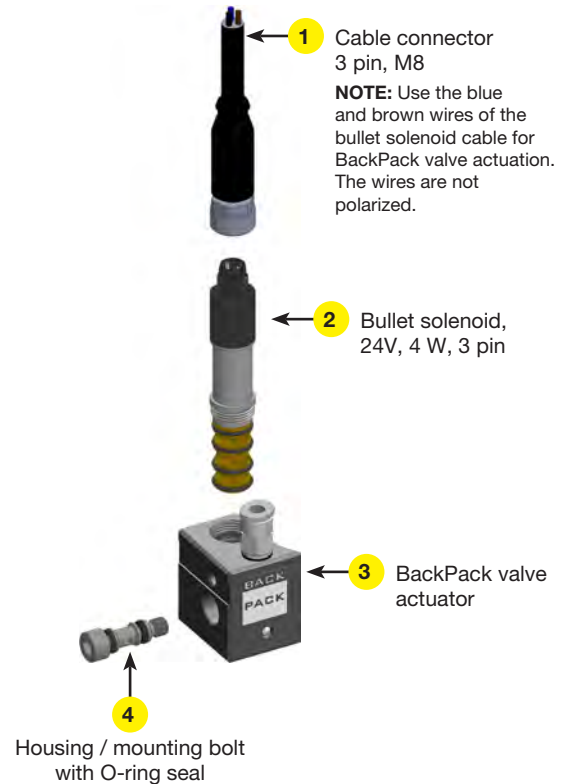

Valve Part Numbers

Standard xQR41	PEEK* xQR41	Description
7360817	7361761	xQR41 valve with Backpack and stroke control knob
7360824	7361763	xQR41 valve with mounting block and stroke control knob
7360821	n/a	xQR41 valve with Backpack, stroke control knob, and bullet end needle**
7360823	n/a	xQR41 valve with mounting block, stroke control knob, and bullet end needle**

*xQR41 valves with PEEK wetted parts resist curing from reactive materials, such as anaerobics.

**Use a bullet end needle with smaller diameter 30 and 32/33 ga tips for more consistent microdot dispensing.

Replacement Parts

Item	Part #	Kit Contents (Qty.)	Item	Part #	Kit Contents (Qty.)
1	7365887	Kit, shafts a. Needle-and-piston assembly, cup end (1) b. PEEK needle-and-piston assembly, bullet end (1) c. Stainless-steel needle-and-piston assembly, bullet end (1) d. Piston spring (1)	4	7365885	Kit, air body / stroke a. Adjustable cap with stroke control knob (1) b. Non-adjustable cap (1) c. Air cylinder body with installed U-cup seal and Rulon bushing (1)
2	7365883	Kit, seals a. Piston O-ring (3) b. Air cylinder body U-cup seal (3) c. Rulon® bushing (2) d. Double-stacked O-rings (Viton®, EPR, and silicone) (20) e. Spring-energized seal (PTFE and carbon-filled PTFE) (3) f. Air inlet O-ring (2) g. Fluid inlet fitting (straight and 90°) (1 each)	5	7365888	Kit, Backpack / mounting block / air inlet fitting a. BackPack value actuator (1) b. Mounting block (1) c. 90° air inlet fitting (1) NOTE: This kit also includes the mounting bolt, bullet solenoid cable, gray air inlet tubing and all associated O-rings.
3	7365884	Kit, fluid assembly a. Fluid body, standard (1) b. Fluid body, PEEK (includes fittings and tubing) (1) c. Retaining nut (1)	Not shown	7365886	Kit, cables / tubing a. Bullet solenoid cable, M8, 3 pin (1) b. Gray air inlet tubing, 3/32 x5/32, 2.4 m (8 ft)

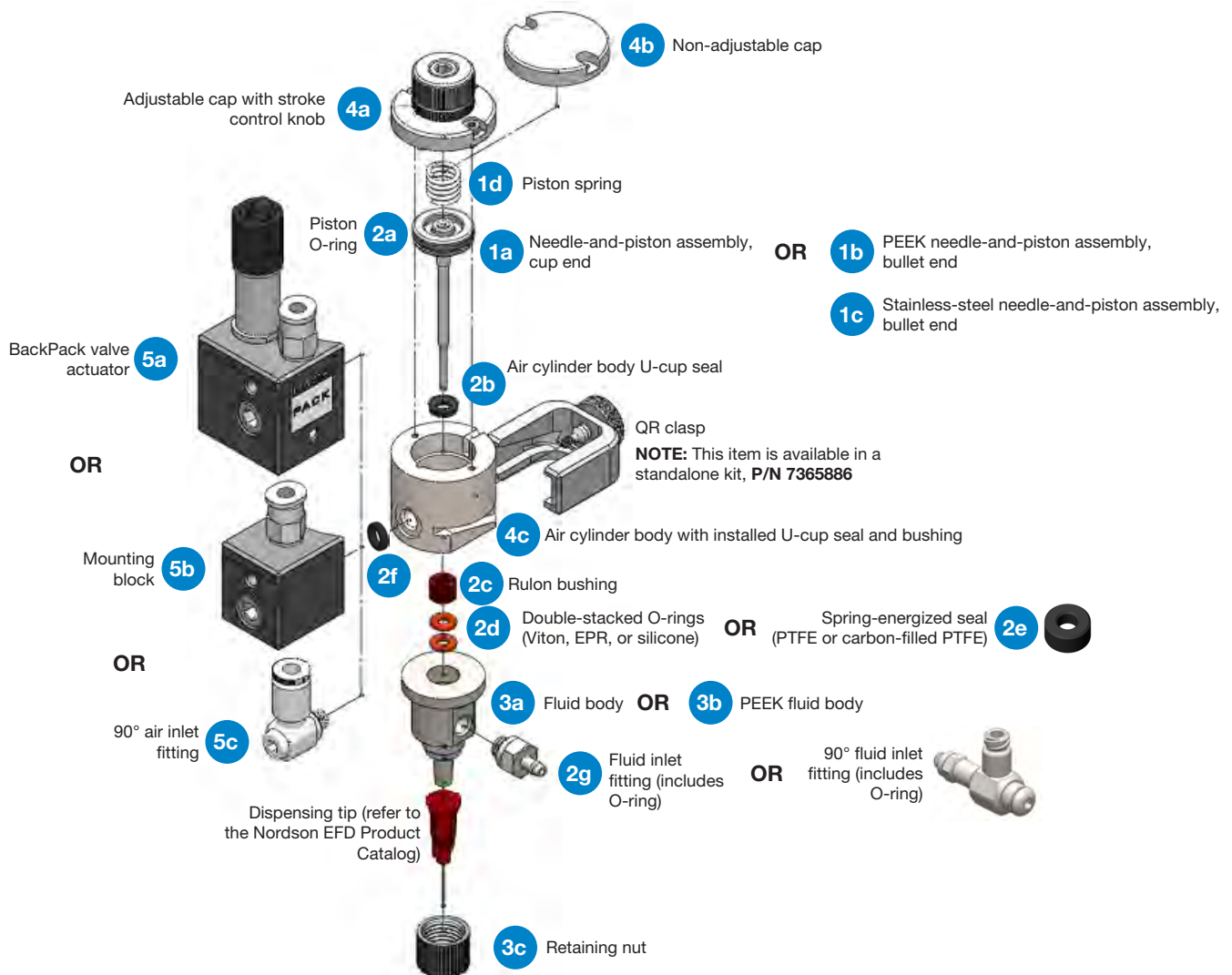

NORDSON EFD ONE YEAR LIMITED WARRANTY

This Nordson EFD product is warranted for one year from the date of purchase to be free from defects in material and workmanship (but not against damage caused by misuse, abrasion, corrosion, negligence, accident, faulty installation, or by dispensing material incompatible with equipment) when the equipment is installed and operated in accordance with factory recommendations and instructions.

Nordson EFD will repair or replace free of charge any defective part upon authorized return of the part prepaid to our factory during the warranty period. The only exceptions are those parts which normally wear and must be replaced routinely, such as, but not limited to, valve diaphragms, seals, valve heads, needles, and nozzles.

In no event shall any liability or obligation of Nordson EFD arising from this warranty exceed the purchase price of the equipment.

Before operation, the user shall determine the suitability of this product for its intended use, and the user assumes all risk and liability whatsoever in connection therewith. Nordson EFD makes no warranty of merchantability or fitness for a particular purpose. In no event shall Nordson EFD be liable for incidental or consequential damages.

This warranty is valid only when oil-free, clean, dry, filtered air is used, where applicable.



For Nordson EFD sales and service in over 40 countries, contact Nordson EFD or go to www.nordsonefd.com.

Global

800-556-3484; +1-401-431-7000
info@nordsonefd.com

Europe

00800 7001 7001
infoefd.europe@nordsonefd.com

Asia

China: +86 (21) 3866 9006; china@nordsonefd.com
India: +91 80 4021 3600; india@nordsonefd.com
Japan: +81 03 5762 2760; japan@nordsonefd.com
Korea: +82-31-736-8321; korea@nordsonefd.com
SEAsia: +65 6796 9522; sin-mal@nordsonefd.com

Rulon is a registered trademark of Saint-Gobain Performance Plastics Corporation.

Viton is a registered trademark of E.I. DuPont.

The Wave Design is a trademark of Nordson Corporation.

©2022 Nordson Corporation 7366010 v072822