

NEPTUNE

WALL/CEILING SPEAKER WITH 5" WOOFER
IP55 RATED

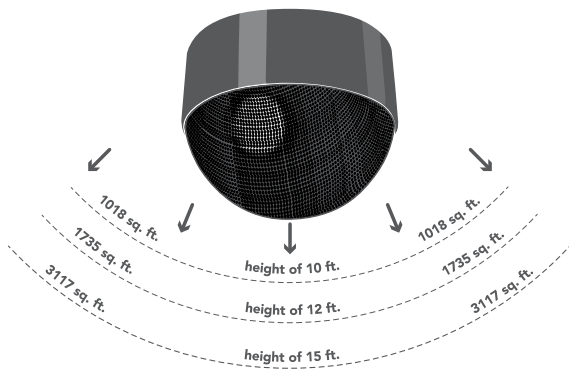

- Complete 360° Sound
- Large Footprint – 1 Neptune Speaker Replaces 4 Ceiling Speakers
- Selectable 70 V / 8 Ω Combination
- Optional Self-Amplified Model Available
- 5-Way (1 ea. 5" Woofer and 4 ea. .5" Tweeters)
- Maximum 65 W Power at 8 Ω
- 70 V Transformer Taps – 3, 6, 12, 25 and 50 W
- Easy, Clean Installation

Specifications:

MODEL NUMBER	NEPTUNE
Description	5-Way, 70 V & 8 Ω Combination 1 ea. 5" Polypropylene Woofer 4 ea. 0.5" PEI Tweeter with Overload Protection
Outdoor / Indoor	Yes
Impedance	70 V and 8 Ω Combination
Sensitivity (1 W / 1 M)	88 dB
Max Power @ 8 Ω	65 W
70 V Tap Settings	30 W / 15 W / 7.5 W / 3.75 W
Nominal Power	50 W
Frequency Response	80 Hz - 20 kHz
Crossover	5 kHz
Dispersion	360° H x 180° V
Woofer Size	5" – 1 Each
Woofer Material	Polypropylene
Tweeter Size	0.5" – 4 Each
Tweeter Material	PEI
Tweeter Overload Protection	Yes
Enclosure	Plastic, IP55 Rated
Grill Material	Aluminum
Dimensions (L x W x H)	9 3/4" x 9 3/4" x 7 1/2"
Net Weight (Unit Only - 5.46 Lbs)	6.35 Lbs.
Total Weight	8.03 Lbs.
Color(s)	Black or White
Mounting Hardware	Covered Bracket
Paintable	Yes
Warranty	5 Years

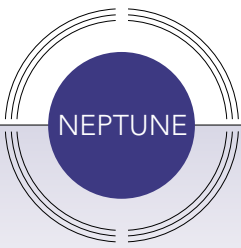

NEPTUNE

WALL / CEILING SPEAKER WITH 5" WOOFER
IP55 RATED



Omni directional wide dispersion surface mount speaker for schools, retail stores, gyms, restaurants, hotels, bars and malls

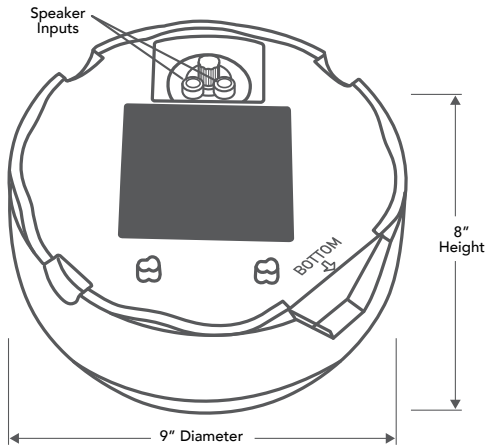
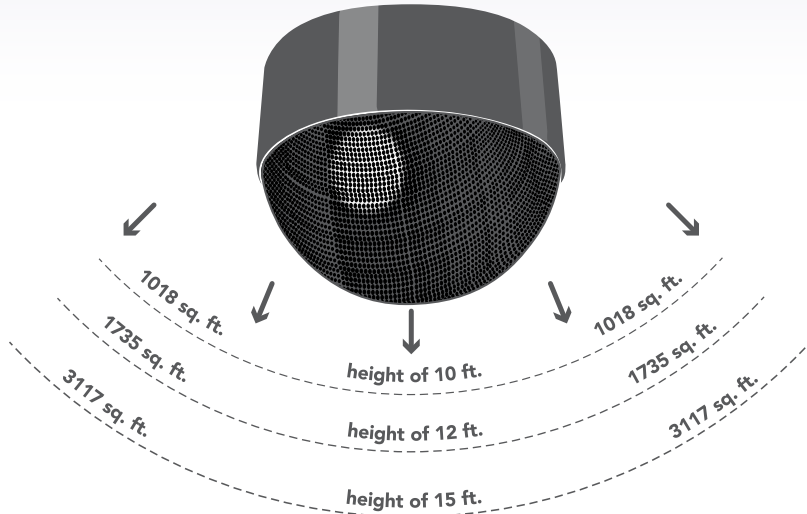

INSTALLATION GUIDE ±3 dB

Height of the Speaker (Ft.)	8'	9'	10'	11'	12'	13'	14'	15'	16'	17'	18'	19'	20'
Distance between Speakers (Ft.)	25	30	36	41	47	52	58	63	69	74	80	85	91
Coverage in Square Feet (Ft ²) per Speaker	491	707	1018	1320	1735	2124	2642	3117	3739	4301	5027	5675	6504



OWI Incorporated
17141 Kingsview Ave.,
Carson, CA 90746 U.S.A.

ph.: 310.515.1900
toll free: 800.638.1694
fax: 310.515.1606
email: info@owi-inc.com



www.owi-inc.com

Specification sheets available for download
owi-inc.com/neptune