

OAKION®

PH550 Benchtop pH Meter Instruction Manual



ISO 9001:2008

Oakton Instruments

www.4oakton.com

Table of Contents

1	Brief Introduction	- 1 -
1.1	Main Features	- 1 -
2	Technical Specifications	- 1 -
3	What's in the Box?	- 2 -
4	Instrument Description	- 2 -
4.1	LCD Display	- 2 -
4.2	Keypad	- 3 -
4.3	Connectors	- 4 -
4.4	Stable reading display mode	- 4 -
4.5	Data storage, recall, and deletion	- 4 -
4.6	Max/Min Function	- 5 -
5	pH Measurement	- 5 -
5.1	Preparation	- 5 -
5.2	pH Electrode Information	- 5 -
5.3	Information regarding Calibration	- 6 -
5.4	pH Meter Calibration	- 8 -
5.5	Measuring pH	- 9 -
5.6	Parameter Setting	- 11 -
5.7	pH Electrode's Maintenance	- 12 -
6	mV measurement	- 13 -
6.1	ORP measurement	- 13 -
6.2	Notes on ORP measurement	- 13 -
7	Recommended pH Electrodes for Specific Applications	- 14 -
8	Warranty	- 14 -

1 Brief Introduction

Thank you for purchasing Oakton Instruments PH550 Benchtop pH meter.

This instrument is an outstanding combination of advanced electronics design and sensor technology. It's the most economical choice of a reliable lab-grade benchtop pH meter. Please read this manual carefully to properly use and maintain the meter. Oakton Instruments reserves the right to update the contents of this manual without giving prior notices.

1.1 Main Features

- The meter has a built-in microprocessor chip, which enables intelligent functions such as automatic calibration, automatic temperature compensation, data storage, parameter setup, max/min reading display, etc.
- The advanced automatic calibration mode has calibration guide and self-diganosis functions, automatically recognizing standard buffer solutions (USA or NIST series).
- The advanced digital processing technology intelligently improves the meter's response time and measuring accuracy with stable reading display mode available.
- The kit comes with a 3-in-1 combination pH Electrode, measuring pH and temperature simultaneously.
- IP54 dustproof and spillproof. Connectors are protected by silicone seal caps, effectively ensuring the reliability and service life of the meter under harsh environment.
- Detachable electrode holder and 3 bottles of pH buffer solutions come with the kit for convenient use.

2 Technical Specifications

pH	Range	0 to 14.00 pH
	Resolution	0.01/0.1 pH
	Accuracy	±0.01 pH ±1 digit
	Temperature Compensation	0 to 100 °C (Auto or Manual)
	Calibration	1 to 3 points automatic calibration
mV	Range	-1999 mV - 0 - 1999 mV
	Resolution	1 mV
	Accuracy	±0.1% F.S ±1 digit
Temp.	Range	0 to 100°C; 32 to 212°F
	Resolution	0.1°C; 0.1/1°F
	Accuracy	±0.5°C ±1 digit
Others	Data Storage	50 groups
	Storage Content	Numberings, Measurement, Unit, Temperature, Temperature Compensation Status
	Power	DC9V/300mA
	IP Ratings	IP54 dustproof and spillproof
	Size and Dimension	(240*235*103) mm/1kg

3 What's in the Box?

	Content	Quantity
3.1	35419-30, PH550 Benchtop pH Meter	1
3.2	35419- 31, Plastic 3-in-1 Combination pH Electrode	1
3.3	pH standard buffer solutions (4.00/7.00/10.01 pH; (50ml for each)	1 for each
3.4	9V Power Adapter	1
3.5	Electrode Holder	1 set
3.6	Instruction Manual	1

4 Instrument Description

4.1 LCD Display

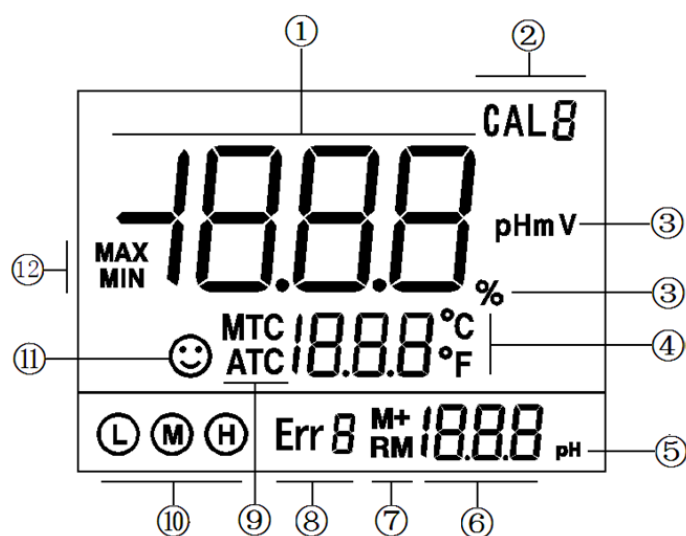

Figure-1

- (1) — Measurement value
- (2) — Calibration icons and numberings
- (3) — Measurement unit
- (4) — Temperature and reminder icons
- (5) — The pH unit displayed during calibration
- (6) — The pH value displayed during calibration, numberings for storage and recall, and reminder icons
- (7) — Icons for data storage and recall — M+: store measuring data; RM: Recall measuring data
- (8) — Self-Diagnosis icons and numberings
- (9) — Temperature compensation mode icons — ATC: Auto Temperature Compensation; MTC: Manual Temperature Compensation
- (10) — Completed calibration icons
- (11) — Stable reading icon
- (12) — Icons for maximum and minimum values

4.2 Keypad

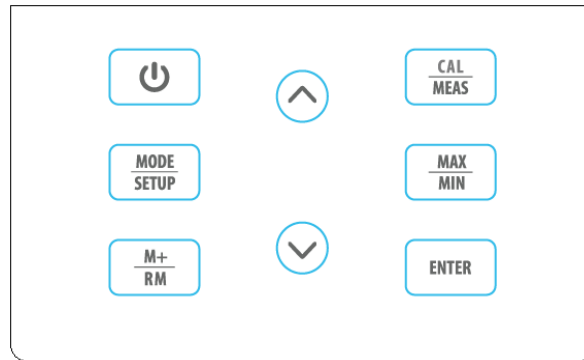

Figure-2

3.2.1. Keypad operations

Short press ----- <1.5 seconds; Long press ----- >1.5 seconds.

3.2.2 For keypad operation, please see Table-1.

Table – 1 Keypad operations and descriptions

Keypad	Operation	Functions
	Short Press	<ul style="list-style-type: none"> Power on/off
	Short Press	<ul style="list-style-type: none"> Select measuring mode: pH→mV.
	Long Press	<ul style="list-style-type: none"> Enter parameter setting: P1→P2→...P4.
	Short Press	<ul style="list-style-type: none"> Enter Calibration mode Cancel any operation and go back to measurement mode
	Short Press	<ul style="list-style-type: none"> In calibration mode, press to conduct calibration In parameter setting, press to confirm selection
	Short Press	<ul style="list-style-type: none"> Store measuring data
	Long Press	<ul style="list-style-type: none"> Recall stored measuring data
 	Short Press or Long Press	<ul style="list-style-type: none"> In manual temperature compensation mode, short press to change temperature, long press to change quickly In parameter setting mode, short press to change parameter and settings. In recall mode, short press to change numberings, long press to change quickly.
	Short Press	<ul style="list-style-type: none"> Buttons for max/min values (refere to section 3.6)

4.3 Connectors

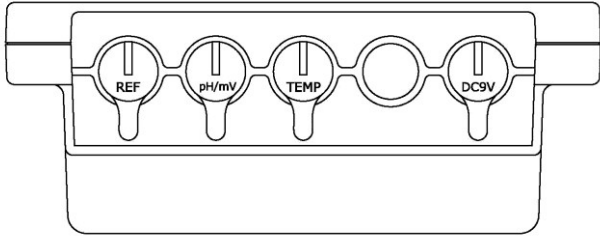

Symbol	Connector Name	Connector Type
REF	Socket for reference electrode	Φ2 banana type
pH/mV	Socket for pH and ORP electrode	BNC
TEMP	Socket for temperature sensor	RCA
DC9V	DC9V power socket	Φ2.5 direct type

4.4 Stable reading display mode

When the measuring value is stable, smiley face icon ☺ appears on LCD, see Figure-3. Please do not get the reading value or make calibration until the ☺ icon appears and stays.

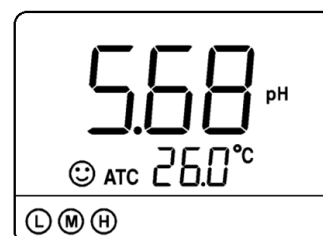



Figure - 3

4.5 Data storage, recall, and deletion

Storage

When the measurement is stable, press  key, the meter displays **M+** icon and storage numberings on LCD, and stores the measuring data. In Figure-4, the meter stores the first group of the measuring data. Press  again, to keep storing.

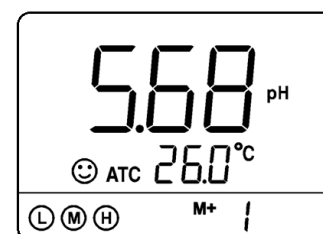



Figure - 4

Recall stored data

In the measurement mode, long press  key to recall the last stored Measuring data. The meter displays **RM** icon and storage numberings.

In Figure-5, the meter is recalling the 28th stored measuring data.

Keep pressing  and  to recall the stored

measuring data successively. Press and hold  and  to quickly recall the stored

measuring data. Short press  to go back to measurement mode.

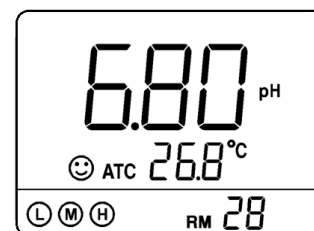



Figure - 5

Clear stored data

The meter can store 50 groups of data. Once the storage is full, if user presses  again, the **FUL** icon will be displayed on LCD (see Figure-6).

The storage needs to be cleared in parameter setting P4 so as to keep storing data. The numberings in **M+** indicates the total number of stored data; The numberings in **RM** indicates the number of stored data in current mode (pH/mV).

For example, if 20 groups of data are stored in pH mode, and 10 groups in mV mode, then the numberings for M+ will be "**M+30**" in both pH and mV mode; the numberings for RM in pH mode would be "**RM20**", in mV mode "**RM10**".

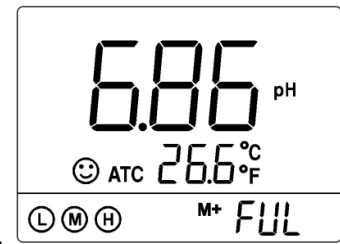





Figure - 6

4.6 Max/Min Function

Use this function to display the maximum or minimum records out of groups of measuring data. In measurement mode, press , LCD will display flashing icons of "**MAX/MIN**", indicating the meter has entered the mode of recording maximum and minimum data. After testing, press  again, LCD will alternately display the maximum and minimum value in the past measurements. Press  to go back to regular measurement mode.

5 pH Measurement

5.1 Preparation

Install the electrode holder

The electrode holder is composed of a metal stand base, a supporting pole, and an electrode clip. First, install the metal stand base to the meter (screw it on). Please note that the metal base can be installed on either side of the meter. Then install the supporting bar on the metal stand base, and then install the electrode clip on the supporting bar.

Connect the power adapter

Plug the power adapter tightly into the DC9V socket. The power's voltage should meet the requirements listed on the power adapter.

Things needed in addition to what's included in the box

A clean cup, distilled water (8-16oz), and tissue papers for rinsing and drying the probe.

5.2 pH Electrode Information

pH Electrode

The meter comes with the 35419-31, 3-in-1 combination electrode with a built-in temperature sensor, which enables the automatic temperature compensation. This electrode is suitable for regular water solutions' pH testing. Please refer to [Section 7](#) for ideal pH electrodes to use for other specific applications. The electrode's housing adopts polycarbonate materials, which is resistant to shocks and corrosion. A 3M KCL storage bottle comes with the electrode, which is for storing the electrode when not in use to keep the sensitivity of the probe.

Technical Specifications of the 201T-F pH Electrode

Measurement Range: 0 - 14 pH, 0 - 80°C (32 – 176°F)

Junction: Single Ceramic

Reference Electrode: Ag/AgCl

Connector: BNC

Size: $\varnothing 12 \times 160$ mm

Temperature unit: 30K Thermistor

Electrode Connectors

The pH electrode has two connectors: the BNC connector connects the pH probe; the RCA connector connects the temperature sensor. Plug these two connectors into ‘pH/mV’ and ‘TEMP’ sockets. Please note not to pull the cables in case of poor contact. Please keep the connectors clean and dry. Refer to section 4.7 regarding how to properly maintain the pH electrode.

Use the Electrode



Screw off the KCL storage bottle, and put it aside (do not dump or spill the KCL solution). Prepare a cup of distilled water, and rinse the electrode in it for a few seconds. Gently shake the probe to remove excess water, and dry it with clean tissue paper (DO NOT rub or wipe the probe, just use paper to dap off excess water). Gently stir the electrode for a few seconds after it's dipped into the test solution and then let it stand still. Wait for the stable measurement (a smiley face appears and stays) and then record the readings. When test is finished, place the electrode in the storage bottle and tighten the cap in order to keep the sensitivity of the pH sensor.

5.3 Information regarding Calibration

pH buffer solutions

The meter has 2 series of standard buffer solutions: USA and NIST (see Table-2). They can be selected in parameter P1 (see 4.6.1).

Table-2

Calibration icon		pH standard buffer series	
		USA	NIST
3-Point calibration		1.68 and 4.00 pH	1.68 and 4.01 pH
		7.00 pH	6.86 pH
		10.01 pH	9.18 pH

3-Point Calibration

The meter can adopt 1 to 3 points of calibration. The 1st point must be using 7.00 pH (or 6.86 pH) buffer solution, and then choose other buffers to do 2nd point and 3rd point. Please refer to Table-3 for details. In the process of calibration, the slope of acidity range and alkalinity range will be displayed, which indicates the health of your probe. The closer the slope is to 100%, the better the condition of the probe is.

Table-3 Calibration Mode

	USA	NIS	Calibration icon	When to adopt
1-Point Calibration	7.00 pH	6.86 pH	(M)	accuracy $\leq \pm 0.1$ pH
2-Point Calibration	7.00 pH and 4.00/1.68 pH	6.86 pH and 4.01/1.68 pH	(L)(M)	Measuring range: 0 to 7.00 pH
	7.00 pH and 10.01 pH	6.86 pH and 9.18 pH	(M)(H)	Measuring range: >7.00 pH
3-Point Calibration	7.00pH, 4.00/1.68 pH and 10.01 pH	6.86pH, 4.01/1.68pH, 9.18 pH	(L)(M)(H)	Wide measuring range

How often to calibrate

The frequency that you need to calibrate your meter depends on the tested samples, condition of electrodes, and the requirement of the accuracy. For High-Accuracy measurements ($\leq \pm 0.02$ pH), the meter should be calibrated before test every time; For ordinary-accuracy measurements ($\geq \pm 0.1$ pH), once calibrated, the meter can be used for several days before recalibration. In the following cases, the meter must be re-calibrated:

- a) The electrode hasn't been used for a long time or a new electrode is connected.
- b) After measuring strong acid (pH<2) or strong base (pH>12) solutions.
- c) After measuring fluoride-containing solution and strong organic solution
- d) There is a significant difference between the temperature of the test sample and the temperature of the buffer solution that is used in the last calibration.

5.4 pH Meter Calibration

1) Press **CAL MEAS** to enter calibration mode. CAL1 icon will flash in the upper right corner of the LCD. 7.00 pH will flash in the lower right corner of the LCD, reminding you to use pH 7.00 buffer to conduct 1st point of calibration.

2) Use distilled water to rinse off electrode and then dry it (with a tissue). Dip it into pH 7.00 buffer solution, stir gently and let it stand still and wait for the reading to become stable. In the lower right corner of LCD, the process of auto recognizing the buffer solution will be displayed. Pressing **ENTER** before the buffer is recognized will generate Er2 (please refer to table 5).

3) When the meter locks 7.00 pH in the lower right corner, stable  displays on LCD. Then press **ENTER** key to calibrate the meter. **End** icon appears after calibration is done.

The 1st point calibration is finished. In the meanwhile, CAL2 will flash at the upper right corner, and 4.00 pH & 10.01 pH will flash alternately at the bottom right, indicating using pH4.00 or pH10.01 buffer solution to make the 2nd point calibration.

4) Take out the pH electrode, rinse it in distilled water, dry it, and dip it into pH 4.00 buffer solution. Stir the solution gently and let stand still in the buffer solution until a stable reading is reached. The meter's display will show the recognition process of calibration buffer solution at the lower right corner. When the meter recognizes 4.00 pH, stable  icon displays on LCD. Press **ENTER** key to calibrate the meter. **End** icon and electrode slope of acidity range will be displayed after calibration is done. In the meanwhile, CL3 will flash at the upper right corner of the LCD, and 10.01 pH will flash at the lower right, indicating using pH10.01 buffer solution to make the 3rd point calibration.

5) Take out pH electrode, rinse it in distilled water, dry it, and dip it into pH 10.01 buffer solution. Stir the solution gently and let it stand still in the

buffer solution until a stable reading is reached. The meter's display will show recognition process of calibration buffer solution at the bottom right of LCD. When the meter recognizes 10.01 pH, stable  icon displays on LCD. Press **ENTER** key to calibrate the meter. **End** icon and electrode slope of alkalinity range

display after calibration is done. The meter returns to the measurement mode, the calibration icons **L M H** will be displayed. Please see Figure-7 for the above calibration process.

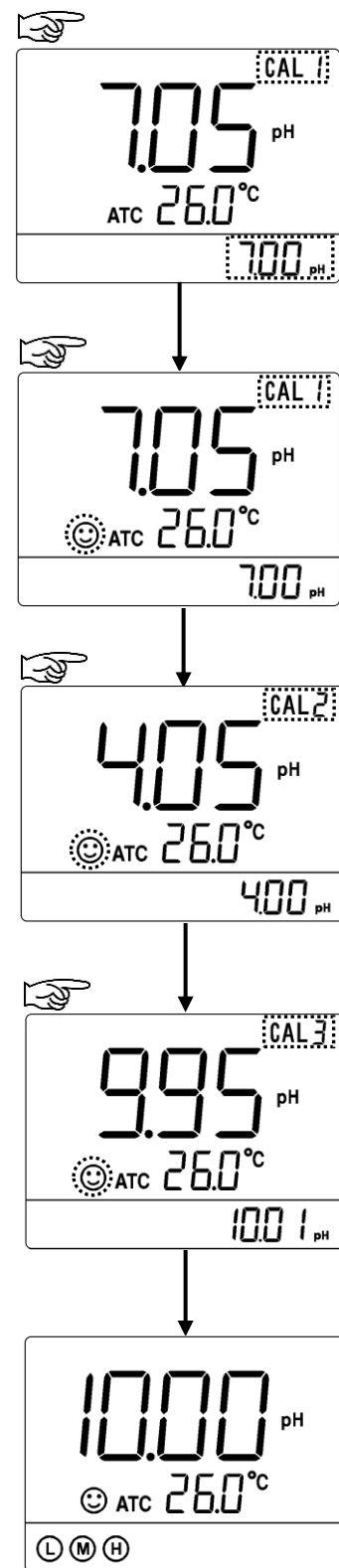



Figure-7

6) During the calibration process, press  key to exit from the calibration mode. The meter can perform one-point, two-point and three-point calibration. Calibration guide icons appear on LCD.

5.5 Measuring pH

Screw off the KCL storage bottle, and put it aside (do not dump or spill the KCL solution). Prepare a cup of distilled water, and rinse the electrode in it for a few seconds. Gently shake the probe to remove excess water, and dry it with clean tissue paper or Kimwipes (DO NOT rub or wipe the probe, just use paper to dap off excess water). Gently stir the electrode for a few seconds after it's dipped into the test solution and then let it stand still. Wait for the stable measurement (a smiley face icon  appears and stays) and then record the readings. Please refer to Figure-8 for calibration and measurement process of the pH meter.

Figure-8 Calibration and measurement process of pH meter



Notes:

- 1) When testing purified water or drinking water, it will take longer for the readings to get stabilized (typically 3-5 minutes) because there are very few ions left to be detected by the sensor in those purified water. A small addition of KCL solution will help with the measurement time.
- 2) Purified water such as distilled water and deionized water are recommended for **only rinsing** the probe for the best result.
- 3) The 35419-31 pH Electrode is **NOT** suitable for testing high-temperature samples (>176°F). Testing high-temperature samples could cause permanent damage to the electrode. A specialized electrode such as LabSen™ 213 (up to 225°F) should be used in this situation.
- 4) The electrode housing is polycarbonate. When using cleaning solutions, take cautions on carbon tetrachloride, trichlorethylene, tetrahydrofuran, acetone, etc., which will dissolve the housing and invalidate the electrode.

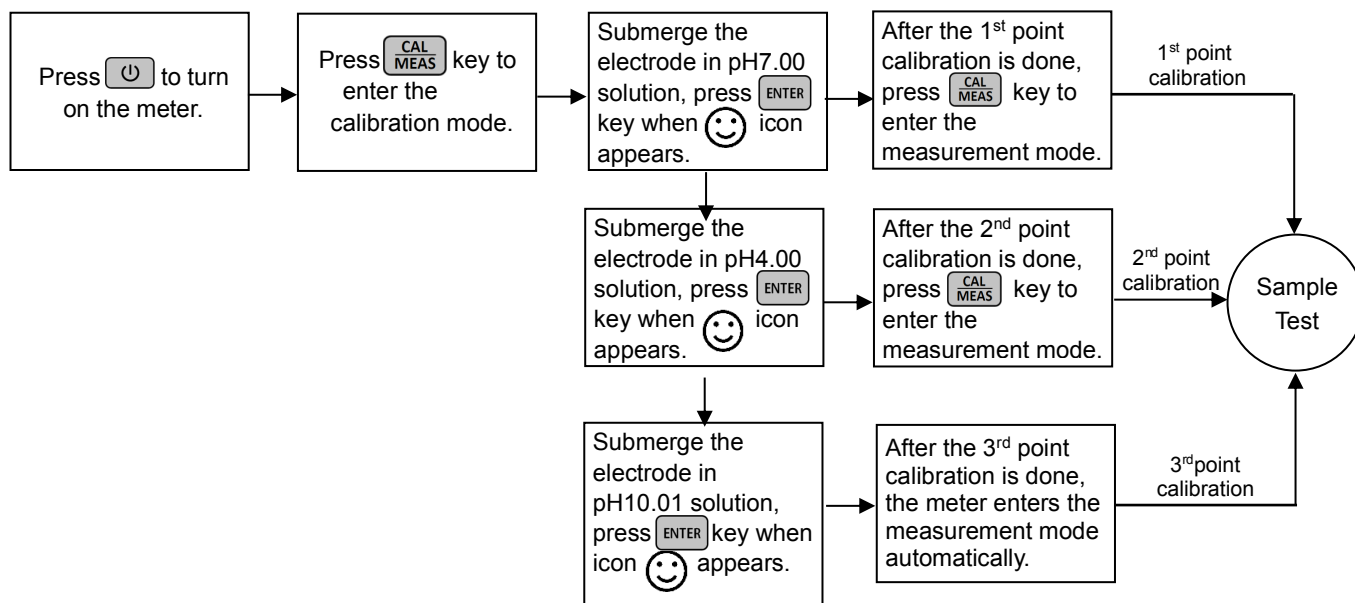
5.5.1 According to the pH isothermal measurement principle, the closer the test sample's temperature is to the calibration solution's, the higher the accuracy of the measurement. This principle is recommended to follow when conducting tests for the best result. Example: If users were to test samples at 150°F, we recommend warming up the calibration solutions to the same temperature before performing calibrations in order to get the most accurate readings.

5.5.2 The instrument has a function to return to factory default setting, which can be set up in P5 (refer to section 5.6). Returning to factory default setting is to restore the meter to theoretical value (zero potential pH is 7.00, slope is 100%), and set all the parameters to default settings. When the meter's calibration or measurement is performing abnormally, users can use this function to let the meter return to factory default mode, and then conduct calibration and test again. Please note that this function is irreversible once used.

5.5.3 Self-Diagnosis

In the process of calibration and measurement, the meter has a self-diagnosis function. Please see table 5.

Table – 5 Self-diagnosis Information

Display Icons	Contents	How to fix
<i>Er 1</i>	Wrong pH buffer solution or the buffer solution is out of range.	<ol style="list-style-type: none"> 1. Check whether pH buffer solution is correct. 2. Check whether the meter connects the electrode properly. 3. Check whether the electrode is damaged. 4. Make sure there is no bubble in the electrode's bulb.
<i>Er 2</i>	pH electrode zero electric potential out of range (<-60mV or >60mV)	<ol style="list-style-type: none"> 1. Make sure there is no bubble in the electrode's bulb. 2. Check whether the electrode is damaged. 3. Check if pH buffer solutions are correct. 4. The pH Electrode is aged. Replace a new one.
<i>Er 3</i>	pH electrode slope is out of range (<85% or >110%)	
<i>Er 4</i>	Press ENTER key when reading is not stable during calibration.	Press ENTER key when 😊 icon appears and stays on the screen.
<i>Er 5</i>	During calibration, the measuring value is not stable for ≥3min.	<ol style="list-style-type: none"> 1. Make sure there is no bubble in the electrode's bulb. 2. Check whether the electrode is damaged. 3. The pH Electrode is aged. Replace a new one.

*** If you find any air bubble in the glass bulb of the pH sensor, invert the probe for a few times to remove it. The existence of an air bubble in the glass bulb will significantly decrease the stability of measurement.**

5.6 Parameter Setting

Table-6

Symbol	Parameter setting content	Parameter	Factory default setting
P1	Select pH buffer series	USA - NIST	USA
P2	Select resolution	0.1/0.01 pH	0.01 pH
P3	Select temperature unit	°C - °F	°C
P4	Clear stored data	No-Yes	No
P5	Return to factory default	No-Yes	No

5.6.1 How to do the parameter setting:

In measurement mode, long press **MODE/STEUP** to enter parameter setting P1. Then press **▲** to change menu from P1 to P2...P5. For details, please see Table-7.

Table-7 pH Parameter Setting

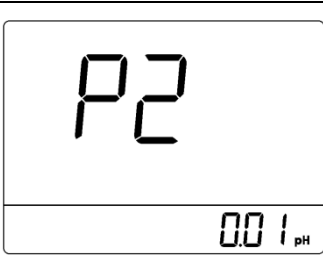
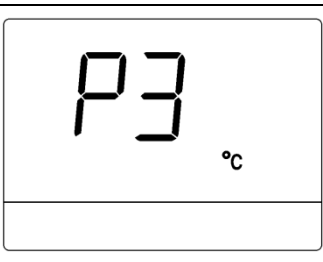
	<p>P1 — Select pH buffer series (USA—NIS)</p> <ol style="list-style-type: none"> 1. Long press MODE/STEUP to enter P1. 2. Press ENTER, USA flashes, press ▲ to select USA or NIS, press ENTER to confirm; USA — USA Series, NIS — NIST Series 3. Press ▲ to enter P2 or press CAL/MEAS to return to measurement mode.
	<p>P2 — Select resolution (0.01—0.1)</p> <ol style="list-style-type: none"> 1. Press ENTER, 0.01 flashes, press ▲ to select 0.01 or 0.1, press ENTER to confirm; 2. Press ▲ to enter P3 or press CAL/MEAS to return to measurement mode.
	<p>P3 — Select temperature unit (°C—°F)</p> <ol style="list-style-type: none"> 1. Press ENTER, °C flashes, press ▲ to select °C or °F, press ENTER to confirm; 2. Press ▲ to enter P4 or press CAL/MEAS to return to measurement mode.

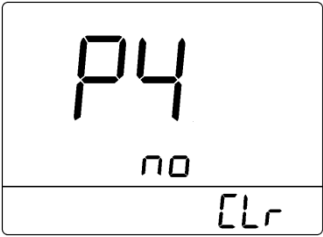
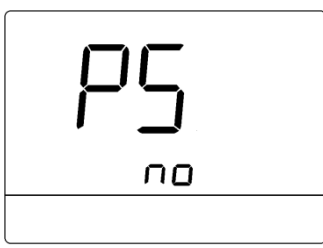
	<p>P4 — Clear stored data (No—Yes)</p> <ol style="list-style-type: none"> 1. Press ENTER, “No” flashes, press ▲ to select No or Yes, press ENTER to confirm; 2. Press ▲ to enter P5 or press CAL MEAS to return to measurement mode.
	<p>P5 — Restore to factory default setting (No—Yes)</p> <ol style="list-style-type: none"> 1. Press ENTER, “No” flashes, press ▲ to select No to Yes, press ENTER to confirm; The meter returns to measurement mode. 2. If not selecting “Yes”, press CAL MEAS to return to measurement mode.

5.7 pH Electrode’s Maintenance

5.7.1 Daily maintenance

The soaking solution contained in the supplied protective bottle is used to maintain hydration of the glass bulb and liquid junction. Loosen the cap, take out the electrode and rinse in distilled or water before taking a measurement. Insert the electrode and tighten the cap after measurements to prevent the solution from leaking. If the storage solution is cloudy or moldy, replace the 3M KCL solution. Oakton electrode storage solution 00653-04.

* The electrode should **NOT** be soaked and stored in **purified or distilled** water, protein solution, acid fluoride solution, or organic lipids. Distilled water or purified water is only recommended for rinsing electrodes.

5.7.2 Calibration buffer solution

For calibration accuracy, the pH of the standard buffer solution must be reliable. The buffer solution should be refreshed often, especially after heavy use. We recommend the Oakton buffer assortment pack 05942-10 which contains 500 mL of pH 4.01, 7.00 and 10.00 pH buffers. The Oakton solution pack 05942-15 includes the three buffers as well as electrode storage and cleaning solutions

5.7.3 Protect glass bulb

The sensitive glass bulb at the front of the combination electrode should not come in contact with hard surfaces. Scratches or cracks on the electrode will cause inaccurate readings. Before and after each measurement, the electrode should be rinsed with distilled water or purified water. If a sample sticks to the electrode or it’s contaminated, the electrode should be thoroughly cleaned using a soft brush with soap water and then rinsed with distilled water. After that, soak it in the KCL solution again for at least 6 hours.

5.7.4 Renew glass bulb

Electrodes that have been used over a long period of time will become aged. Submerge the electrode in 0.1mol/L hydrochloric acid for 24 hours, then rinse the electrode in distilled water, then submerge it in KCL storage solution 00653-04 for 24 hours.

The method to prepare 0.1mol/L hydrochloric acid: dilute 9mL hydrochloric acid in distilled water to 1000mL.



5.7.5 Clean contaminated glass bulb and junction (please refer to Table-8)

Table-8 Clean contaminated glass bulb and junction

<u>Contamination</u>	<u>Cleaning Solutions</u>
Inorganic metal oxide	Dilute acid less than 1mol/L
Organic lipid	Dilute detergent (weak alkaline)
Resin macromolecule	Dilute alcohol, acetone, ether
Proteinic haematocyte sediment	Acidic enzymatic solution (saccharated yeast tablets)
Paints	Dilute bleach, peroxide

6 mV measurement

6.1 ORP measurement

Press  key, and switch the meter to mV measurement mode. Connect ORP electrode (the 301Pt-C combination ORP electrode is sold separately) and dip it in sample solution, stir the solution briefly and allow it to stay in the solution until  icon appears and get the reading.

ORP means Oxidation Reduction Potential. The unit is mV.

6.2 Notes on ORP measurement

6.2.1 ORP measurement does not require calibration. When the user is not sure about ORP electrode quality or measuring value, use ORP standard solution to test mV value and see whether ORP electrode or meter works properly. Table-9 is the data of standard (Zobell) ORP solution for 222 mV.

Table-9

°C	10	15	20	25	30	35	38	40
mV	242	235	227	222	215	209	205	201

6.2.2 Clean and activate ORP electrode

After the electrode has been used over a long period of time, the platinum surface will get polluted which causes inaccurate measurement and slow response. Please refer to the following methods to clean and activate ORP electrode:

- For inorganic pollutant, submerge the electrode in 0.1mol/L dilute hydrochloric acid for 30 minutes, then wash it in distilled water, then submerge it in the electrode storage solution 00653-04 for 6 hours.
- For organic or lipid pollutant, clean the platinum surface with detergent, then wash it in distilled water, then submerge it in the electrode storage solution 00653-04 for 6 hours.
- For heavily polluted platinum surface on which there is oxidation film, polish the platinum surface with toothpaste, then wash it in distilled water, then submerge it in the electrode storage solution 00653-04 for 6 hours.

7 Recommended pH Electrodes for Specific Applications

Application	Oakton pH Electrodes to Use with PH550 Meter
Regular water solutions	35419-31
Beverage, beer, or wine analysis	35419-31
Dilute acids & bases	35419-31
Dairy products (milk, cream, yogurt, mayo, etc.)	35419-31
Low-temperature liquid	35419-31
Soil	35419-31
Titration	35419-31
Drinking water	35419-31

8 Warranty

We warrant this instrument to be free from defects in material and workmanship and agree to repair or replace free of charge, at option of OAKTON INSTRUMENTS, any malfunctioned or damaged product attributable to responsibility of OAKTON INSTRUMENTS, for a period of THREE YEARS (SIX MONTHS for the probe) from the delivery.

This limited warranty does not cover any damages due to:

Transportation, storage, improper use, failure to follow the product instructions or to perform any preventive maintenance, modifications, combination or use with any products, materials, processes, systems or other matter not provided or authorized in writing by us, unauthorized repair, normal wear and tear, or external causes such as accidents, abuse, or other actions or events beyond our reasonable control.

OAKTON INSTRUMENTS

PO Box 5136

Vernon Hills, IL. 60061

Tel: 1-888-462-5866

Email: sales@4oakton.com

Website: www.4oakton.com