

User Manual



Thermohygrometer with Single Type K Input and Superheat Function

with NIST-Traceable Calibration

Model 20250-12

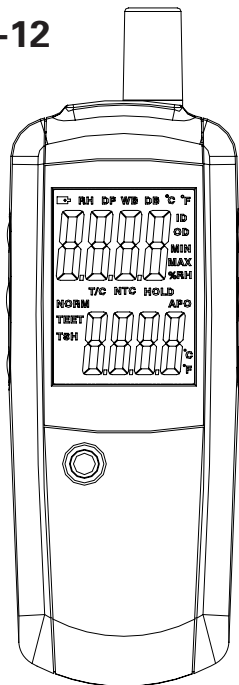

THE STANDARD IN PRECISION MEASUREMENT

Introduction

The Digi-Sense Thermohygrometer (Model 20250-12) with Single Type K Input and Superheat Function offers fast response and high accuracy. This meter is both a digital thermohygrometer and a valuable HVAC diagnostic tool—it measures humidity, dew point, wet bulb, dry bulb, temperature, plus target superheat (TSH) and target evaporator exit temperature (TEET). Meter also features Min/Max/Hold readings and automatic power-off, and accepts a wide variety of thermocouple probes. The instrument is fully tested and calibrated to NIST-traceable standards. Careful use of this meter will provide years of reliable service.

Unpacking

Carefully unpack the instrument and accessories from shipping package. Check individual parts against the list of items below. If anything is missing or damaged, please contact Cole-Parmer immediately.

1. Meter
2. One type K flexible probe
3. Carrying pouch
4. Three AAA batteries
5. User manual
6. NIST-traceable calibration report with data

Meter Description

1. Thermocouple type K input
2. Thermistor temperature sensor (internal)
3. **MODE** button
4. **ENTER** button
5. **OUTPUT** button
6. °C/°F /  **Backlight** button
7. **SENSOR** button
8. **MAX/MIN/HOLD** button
9. **Power On/Off** button
10. LCD
11. Humidity sensor (internal)
12. Battery cover

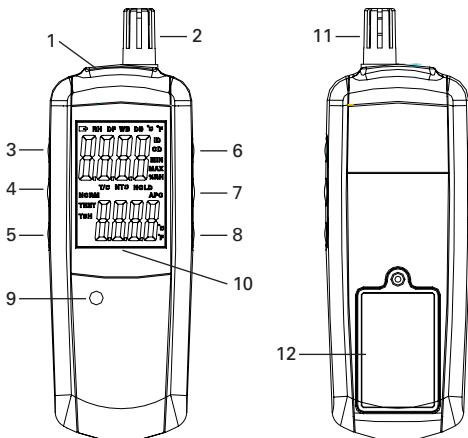

Display Functions

1. Low-battery indication
2. Measurement icons (RH, DP, WB, DB)
3. °C/°F icons for upper display
4. Indoor (ID) / Outdoor (OD) icons
5. Upper measurement display of humidity, dew point, wet bulb, dry bulb, temperature
6. MIN / MAX icons
7. Humidity measurement (%RH) icon
8. HOLD icon
9. Thermocouple (T/C) and Thermistor (NTC) icons
10. MODE select icons (NORM, TEET, TSH)
11. Auto power-off (APO) indication
12. Lower measurement display of target superheat and target evaporator exit temperature
13. °C/°F icons for lower display

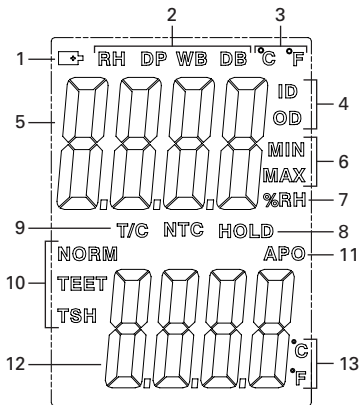

Setup and Operation

Power

Press the **Power on/off** button to turn unit on.

Taking Measurements

1. Hold the sensor in the area to be tested.
2. Allow adequate time for readings to stabilize.
3. Press the **MODE** button until the **NORM** icon is displayed on the screen.
4. Press the **SENSOR** button and hold for two seconds to select the temperature sensor in use: either **T/C** for external thermocouple or **NTC** for internal thermistor.
5. While in the internal sensor (**NTC**) mode, use the **SENSOR** button to toggle between other available measurements: humidity (**RH**), dew point (**DP**), wet bulb (**WB**), and dry bulb (**DB**). The icon displayed indicates the selected measurement.
6. Press the **°C/°F / Backlight** button to select either °C or °F temperature units.

Viewing the Min and Max Readings and Hold Function

1. Press **MAX/MIN/HOLD** button to step through the minimum (MIN), maximum (MAX), and Hold readings.
2. Press **MAX/MIN/HOLD** button again to exit the MAX/MIN/HOLD mode.

LCD Backlight

Press and hold the **°C/°F / Backlight** button for two seconds to turn backlight on or off.

Setup and Operation (continued)

Automatic Power-Off

To conserve battery life, the meter automatically turns off after 15 minutes. To disable this feature:

1. Turn the meter off.
2. Press and hold the **MAX/MIN/HOLD** button while powering on.
3. The "APO" will no longer be shown on the display, indicating that the Auto power-off feature is disabled.
4. Note that Auto power-off is re-enabled each time the meter is turned on.

Using Target Superheat Mode (TSH)

1. Press the **MODE** button until the **TSH** icon is displayed on the screen.
 - a. Blinking numbers indicate that you are in the unlocked mode and seeing real-time measurements.
 - b. Solid non-blinking numbers indicate that the reading has been "locked."
 - c. Press the **ENTER** button to unlock and take a new reading, and then press **ENTER** button again to relock the measurement.

Setup and Operation (continued)

2. While the numbers are blinking (unlocked mode), press and hold the **SENSOR** button until the **NTC** icon is displayed. Press **SENSOR** button again to select either the **WB** or **DB icon**.
 - a. When the **WB** icon is displayed, place the internal sensor cap in front of the indoor air return and press the **ENTER** button when the reading is stable.
 - b. When the **DB** icon is displayed, place the internal sensor cap in front of the condenser and press the **ENTER** button when the reading is stable.
3. Press the **OUTPUT** button to display the Target Superheat temperature in the lower display.
4. Compare the Target Superheat temperature to the Actual Superheat temperature. Adjust refrigerant levels accordingly for a fixed restrictor system.
 - a. If Actual Superheat is higher than Target Superheat, add refrigerant.
 - b. If Actual Superheat is lower than Target Superheat, recover refrigerant.

Setup and Operation (continued)

Using Target Evaporator Exit Temperature (TEET)

1. Two thermocouple probes are required for a **TEET** measurement.
2. Press the **MODE** button until the **TEET** icon is displayed on the screen.
 - a. Blinking numbers indicate that you are in the unlocked mode and seeing real-time measurements.
 - b. Solid non-blinking numbers indicate that the reading has been "locked."
 - c. Press the **ENTER** button to unlock and take a new reading, and then press **ENTER** button again to relock the measurement.
3. Insert thermocouple "A" into a sock and wet the sock.
4. Clip both thermocouples (thermocouple "A" and thermocouple "B") in front of the evaporator.
5. Plug thermocouple "A" into the top of the meter.
Note: If "OL" is displayed, then the measurements are out of range. Retake the temperature measurements and ensure the temperature inputs are set correctly.
6. Press the **SENSOR** button until the **WB** icon is displayed. Press and hold the **SENSOR** button until the **T/C** icon is displayed. When reading is stable, press the **ENTER** button to lock the reading.
7. Unplug the thermocouple "A" and plug in the thermocouple "B".

Setup and Operation (continued)

8. Press the **SENSOR** button until the **DB** icon is displayed. Press and hold the **SENSOR** button until the **T/C** icon is displayed. When reading is stable, press the **ENTER** button to lock the reading.
9. Press **OUTPUT** button and read the Target Evaporator Exit Temperature (TEET) in the lower display.
Note: If "OL" is displayed, then the measurements are out of range. Retake the temperature measurements and ensure the temperature inputs are set correctly.
10. Compare the Target Evaporator Exit Temperature to the Actual Evaporator Exit Temperature. The Actual Evaporator Exit Temperature is the measured temperature of the air after it has passed through the evaporator. Adjust airflow accordingly.
 - a. An Actual Evaporator Exit Temperature below the Target Evaporator Exit Temperature indicates low airflow. Increasing airflow can be accomplished by eliminating restrictions in the duct system, increasing blower speed, cleaning filters or opening registers.
 - b. An Actual Evaporator Exit Temperature above the Evaporator Exit Temperature usually indicates low capacity. Occasionally airflow is higher than expected. Look for causes of low capacity such as refrigerant mischarge or a dirty condenser coil. If the airflow is high, correct it by lowering the fan speed.

Specifications

Range	
Humidity	0 to 100% RH
Temperature, external type K thermocouple (T/C)	-328 to 2501°F (-200 to 1372°C)
Temperature, internal thermistor sensor (NTC)	32 to 140°F (0 to 60°C)
Dew point (calculated)	-22 to 212°F (-30 to 100°C)
Wet bulb (calculated)	32 to 176°F (0 to 80°C)
Resolution	
Humidity	0.1% RH
Temperature, external type K thermocouple (T/C)	0.1° (<1000°) or 1° (≥1000°)
Temperature, internal thermistor sensor (NTC)	0.1°
Accuracy	
Humidity	±2.5% RH from 10 to 90% RH ±5% RH from 0 to 10% RH and 90 to 100% RH
Temperature, external type K thermocouple (T/C)	±[0.5% reading + 1.8°F (1°C)] above -148°F (-100°C) ±[0.5% reading + 3.6°F (2°C)] below -148°F (-100°C)
Temperature, internal thermistor sensor (NTC)	±1.8°F (1°C)

Specifications (continued)

Auto power-off	Unit shuts off automatically after 15 minutes to preserve battery life
Operating temperature	32 to 122°F (0 to 50°C)
Storage temperature	14 to 122°F (-10 to 50°C)
Weight	6 oz (173 g)
Dimensions	7¼" x 2½" x 1" (18.5 x 6.3 x 2.6 cm)
Power	Three AAA 1.5 V batteries

Maintenance

Cleaning and storage

1. The meter should be cleaned with a damp cloth and mild detergent when necessary. Do not use solvents or abrasives.
2. Store the meter in an area with moderate temperature and humidity (refer to the operating and storage range in the specifications chart earlier in this manual).

Battery Replacement

When the battery power falls low, the low-battery icon will appear on the screen. Replace the three AAA batteries by removing the screw holding the rear battery compartment cover to access the battery compartment. Ensure that the compartment cover is securely fastened when finished.

Maintenance, Recalibration, and Repair

It is recommended that Digi-Sense products are calibrated annually to ensure proper function and accurate measurements; however, your quality system or regulatory body may require more frequent calibrations. To schedule your recalibration, please contact InnoCal, an ISO 17025 calibration laboratory accredited by A2LA.

INNOCAL®

INNOVATIVE CALIBRATION SOLUTIONS

Phone: 1-866-INNOCAL (1-866-466-6225)

Fax: 1-847-327-2993

E-mail: sales@innocalsolutions.com

Web: InnoCalSolutions.com

For Product and Ordering Information, Contact:

 **Cole-Parmer®**
Delivering Solutions You Trust

Toll-Free: 1-800-323-4340

Phone: 1-847-549-7600

Fax: 1-847-247-2929

ColeParmer.com/Digi-Sense

Proven. Precise. Personal.

Toll-Free: 1-800-358-5525

Phone: 1-847-327-2000

Fax: 1-847-327-2700

Davis.com/Digi-Sense