

## Ogee Mobile

Product Number: 55471-DD, 55471-PP

### OVERVIEW

The MooreCo Go offers up to twice the functional writing surface of a wall-mounted board with a sturdy, mobile, steel frame.

### BOARDS

Boards are magnetic markerboard constructed of a 1/4" MDF core with 28 gauge porcelain steel. Optionally available with a painted steel surface.

### FRAME

The platinum frame is made of two upright curved pieces, and two trays that act as crossbars. The two uprights are welded 1" square 16 Ga steel tubes that are welded to a 16 Ga steel plate forming a .25" channel for the markerboards. The uprights are attached at the bottom with a 34" x 23.375" 16 Ga steel tray and four M6 x 15mm screws. welded to this tray are two 2" x 8" steel plates that support the center of the markerboards. The second tray is a 6.375" x 34" 16 Ga steel tray with a 1" diameter handle attached to the uprights with four M6 x 15mm screws. Both trays are lined with foam rubber. Across the top is a 2.625" wide 16 ga channel with two 14 Ga inserts welded inside to form two .25" channels for the markerboard. This upper channel is attached with two M6 x 15mm screws. The frame is attached to four 2.5" casters with M10 x 15mm stems.

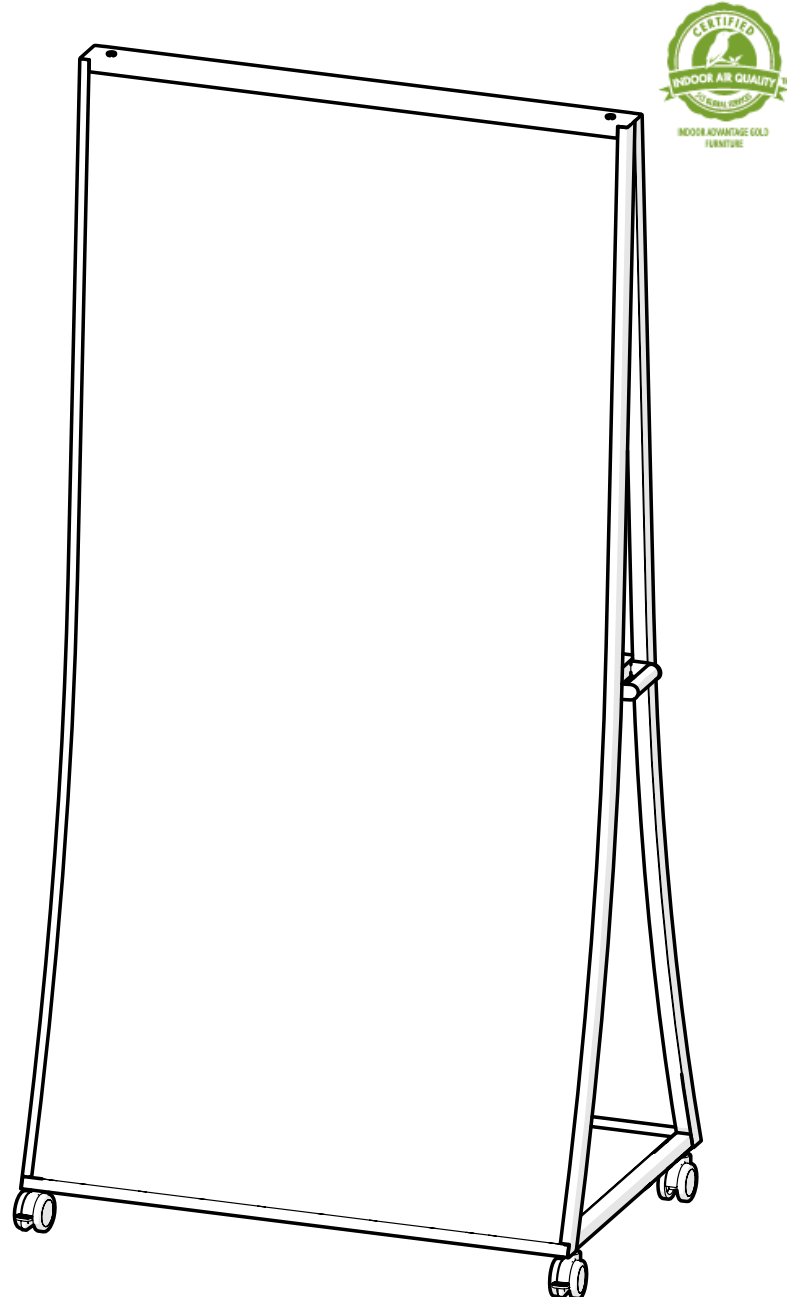

### FRAME COLOR:



Platinum

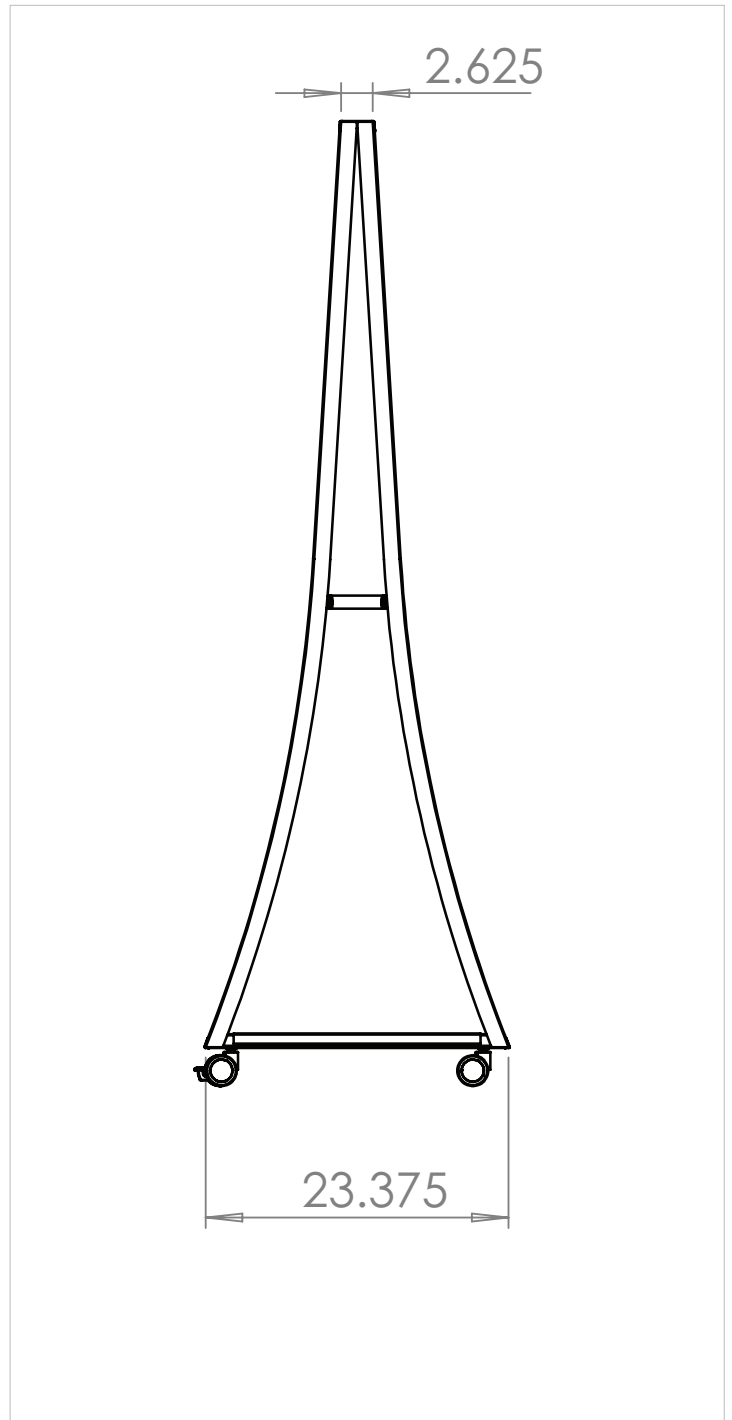
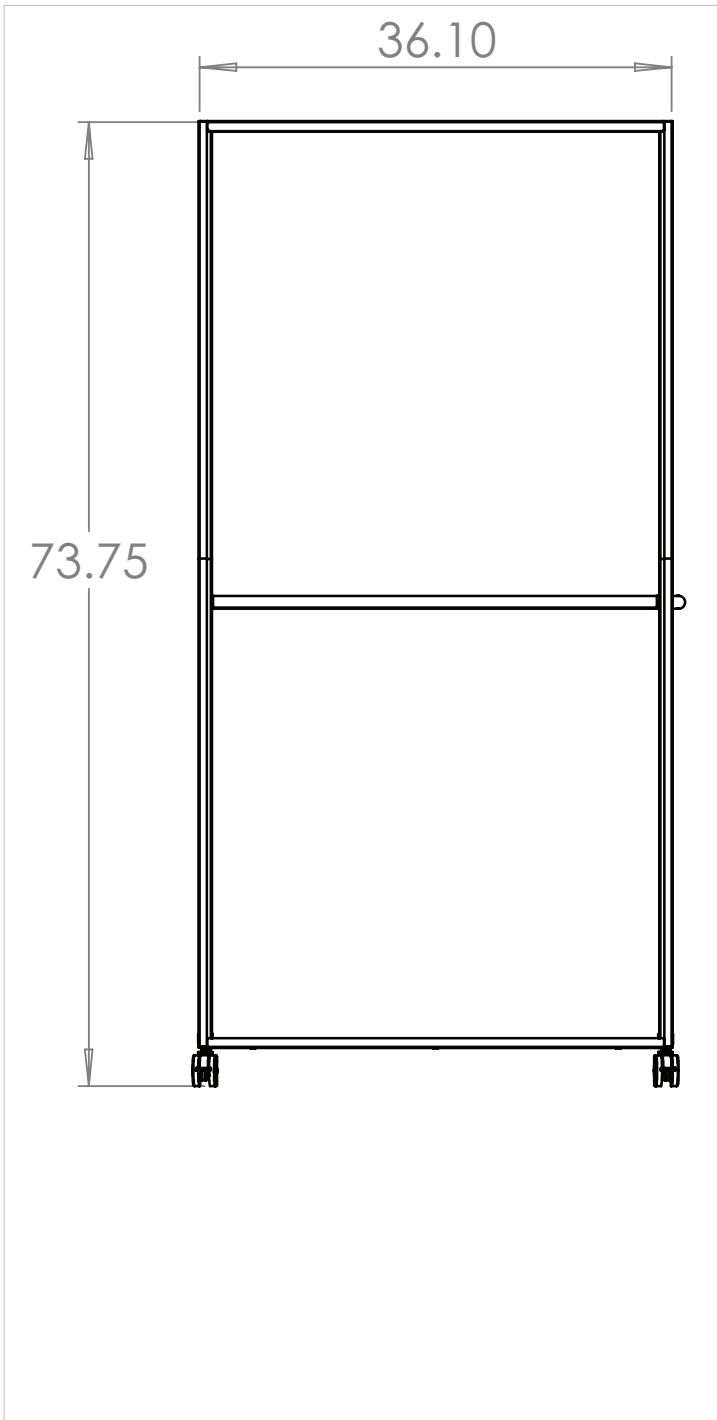

**DIMENSIONS:**

Base Model No.	Description	Height	Width	Depth
55471-DD	Ogee Mobile-Porcelain Steel Board	73.75"	36.10"	23.375"
55471-PP	Ogee Mobile-Magnarite Board	73.75"	36.10"	23.375"