

DEFENDER® 6000 WASHDOWN

Extreme Washdown Bench Scales

Display

White LED with 20 mm / 0.8 in high digits and 3 color (red, green, orange) 8 × 16 dot matrix LED checkweighing/filling display.

Communication

Built-in RS232 and USB host, Hands-free, touchless sensor reduces contamination risk; optional 2nd RS232/RS485/USB Device, Analog Output, Wi-Fi/Bluetooth, Ethernet and Discrete I/O with relays.

Construction

All 316 Stainless Steel indicator, column and base with hermetically-sealed load cell. Pan optional on 10 × 10 in and 12 × 12 in bases.

Design Features

Up to 10,000d/5,000e NTEP certified and Measurement Canada approved Class III legal-for-trade, GMP/GLP output with time/date, EasyConnect connector allows fast set-up, hardwired internal AC power supply included—optional external USB powerbankholder available.



Defender 6000 stands up to harsh cleaning in processing and packaging environments with IP68 immersion/ IP69K washdown protection, 316 stainless steel construction and hermetically-sealed load cell.

Durable Defender 6000 is NSF certified, supporting HACCP systems with a 316 stainless steel base and sturdy indicator providing corrosion protection in food, chemical processing, and packaging.

Includes Library for up to 300 items and can support up to 100 user profiles for easy data management. Configurable data output with GMP/GLP and time/date for result traceability. Numeric keypad and dedicated target key for fast item setup.

| Model | Capacity | Readability | Certified Readability | Platform Size | Item No. | List Price (USD) |
|-----------------|-----------------|------------------|-----------------------|-------------------------------|----------|------------------|
| i-D61XWESK1S6 | 10 lb / 5 kg | 0.001 lb / 0.5 g | 0.002 lb / 1 g | 9.8 × 9.8 in / 250 × 250 mm | 30575563 | 1915 |
| i-D61XWE12K1R6 | 25 lb / 12.5 kg | 0.002 lb / 1 g | 0.005 lb / 5 g | 11.8 × 11.8 in / 300 × 300 mm | 30575564 | 1995 |
| i-D61XWE25K1R6 | 50 lb / 25 kg | 0.005 lb / 2 g | 0.01 lb / 5 g | 11.8 × 11.8 in / 300 × 300 mm | 30575565 | 1995 |
| i-D61XWE50K1L7 | 100 lb / 50 kg | 0.01 lb / 5 g | 0.02 lb / 10 g | 19.7 × 15.7 in / 500 × 400 mm | 30575566 | 2350 |
| i-D61XWE150K1L7 | 300 lb / 150 kg | 0.02 lb / 10 g | 0.1 lb / 50 g | 19.7 × 15.7 in / 500 × 400 mm | 30575567 | 2350 |

| Accessories | Item No. | List Price (USD) |
|--|----------|------------------|
| Wi-Fi/Bluetooth Dongle | 30412537 | 231 |
| RS232/RS485/USB Device Kit | 30424404 | 167 |
| Ethernet Kit | 30429666 | 167 |
| Analog Output Kit | 30424403 | 167 |
| Discrete I/O with Relay Kit (2 In/4 Out) | 30097591 | 155 |
| Light Tower, 3 Colors, 243 mm, IP65 (requires 30097591) | 30424021 | 194 |
| External Power Bank Holder, 304 Stainless Steel (requires external USB power bank) | 30572907 | 275 |

| Accessories | Item No. | List Price (USD) |
|-------------------------------------|----------|------------------|
| RS232 Cable | 80500552 | 179 |
| M16 Gland with Ferrite | 30379716 | 21 |
| Alibi Memory | 80500503 | 123 |
| 30' Loadcell Extension Cable (9 m) | 30424409 | 167 |
| Wheel Kit, 304 Stainless Steel | 30616409 | 167 |
| Pan 12 × 12 in, 304 Stainless Steel | 30427798 | 93 |
| Pan 10 × 10 in, 304 Stainless Steel | 30427799 | 78 |

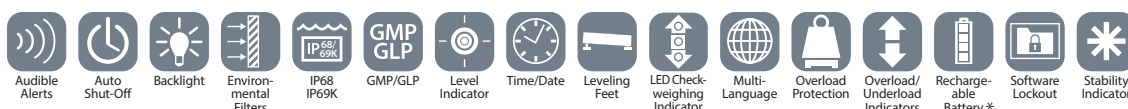

*Option

DEFENDER® 6000 WASHDOWN

Extreme Washdown Bench Scales

Display

White backlit LCD display with 45 mm / 1.8 in high digits. Wide 3 Color (red, green, yellow) LED Bar spans width of display for clear checkweighing results.

Communication

Built-in RS232 requires optional IR connector.

Construction

316 Stainless Steel base with hermetically-sealed load cell. Polycarbonate indicator can be mounted on 316 column or front mount. Pan optional on 10 × 10 in and 12 × 12 in bases.

Design Features

Up to 10,000d/5,000e NTEP certified and Measurement Canada approved Class III legal-for-trade, GMP/GLP output with time/date, EasyConnect connector allows fast set-up, powered by 6 "D" cell batteries for up to 1,600 hours of use.

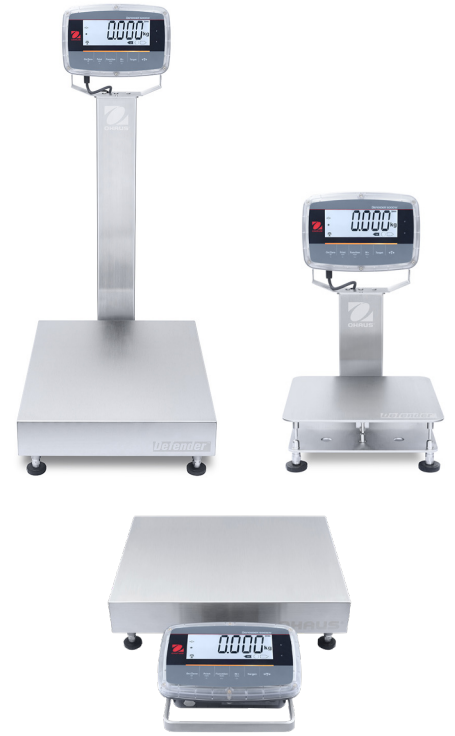

Optional IR RS232 kit

Defender 6000 stands up to harsh cleaning in processing and packaging environments with IP68 immersion/ IP69K washdown protection, polycarbonate indicator, 316 stainless steel base and column construction and hermetically-sealed load cell.

Durable Defender 6000 is NSF certified, supporting HACCP systems with a 316 stainless steel base and sturdy polycarbonate indicator providing corrosion protection in food, chemical processing, and packaging.

Can store up to 1,000 weighing results in memory for download using optional IR data connector. Configurable data output with GMP/GLP and time/date for result traceability. Dedicated target key for fast item setup.

Scale with Column

| Model | Capacity | Readability | Certified Readability | Platform Size | Item No. | List Price (USD) |
|----------------|-----------------|------------------|-----------------------|-------------------------------|----------|------------------|
| i-D61PW5K1S6 | 10 lb / 5 kg | 0.001 lb / 0.5 g | 0.002 lb / 1 g | 9.8 × 9.8 in / 250 × 250 mm | 30575569 | 1825 |
| i-D61PW12K1R6 | 25 lb / 12.5 kg | 0.002 lb / 1 g | 0.005 lb / 5 g | 11.8 × 11.8 in / 300 × 300 mm | 30575570 | 1925 |
| i-D61PW25K1R6 | 50 lb / 25 kg | 0.005 lb / 2 g | 0.01 lb / 5 g | 11.8 × 11.8 in / 300 × 300 mm | 30575571 | 1925 |
| i-D61PW50K1L7 | 100 lb / 50 kg | 0.01 lb / 5 g | 0.02 lb / 10 g | 19.7 × 15.7 in / 500 × 400 mm | 30575572 | 2475 |
| i-D61PW150K1L7 | 300 lb / 150 kg | 0.02 lb / 10 g | 0.1 lb / 50 g | 19.7 × 15.7 in / 500 × 400 mm | 30575573 | 2475 |

Scale with Front Mount

| Model | Capacity | Readability | Certified Readability | Platform Size | Item No. | List Price (USD) |
|----------------|-----------------|------------------|-----------------------|-------------------------------|----------|------------------|
| i-D61PW5K1S5 | 10 lb / 5 kg | 0.001 lb / 0.5 g | 0.002 lb / 1 g | 9.8 × 9.8 in / 250 × 250 mm | 30575568 | 1875 |
| i-D61PW12K1R5 | 25 lb / 12.5 kg | 0.002 lb / 1 g | 0.005 lb / 5 g | 11.8 × 11.8 in / 300 × 300 mm | 30575562 | 1950 |
| i-D61PW25K1R5 | 50 lb / 25 kg | 0.005 lb / 2g | 0.01 lb / 5 g | 11.8 × 11.8 in / 300 × 300 mm | 30608733 | 1950 |
| i-D61PW50K1L5 | 100 lb / 50 kg | 0.01 lb / 5 g | 0.02 lb / 10 g | 19.7 × 15.7 in / 500 × 400 mm | 30608734 | 2525 |
| i-D61PW150K1L5 | 300 lb / 150 kg | 0.02 lb / 10 g | 0.1 lb / 50 g | 19.7 × 15.7 in / 500 × 400 mm | 30608735 | 2525 |

Accessories

| Accessories | Item No. | List Price (USD) |
|-------------------------------------|----------|------------------|
| IR Communication Kit | 30572910 | 75 |
| 30' Loadcell Extension Cable (9 m) | 30424409 | 167 |
| Wheel Kit, 304 Stainless Steel | 30616409 | 167 |
| Pan 12 × 12 in, 304 Stainless Steel | 30427798 | 93 |
| Pan 10 × 10 in, 304 Stainless Steel | 30427799 | 78 |

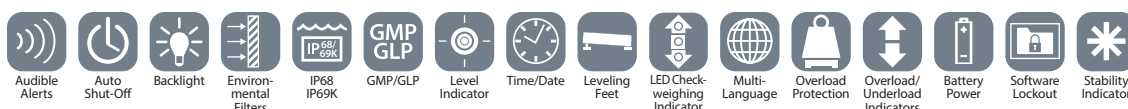

DEFENDER® 6000 INDICATORS WITH DEFENDER W BASES

Washdown Bench Scales

Construction

Defender 6000 XWE or PW IP68/IP69K Indicators, Defender W 304 Stainless Steel Bases with IP67 stainless steel loadcells. Columns and Front Mounts 304 Stainless Steel.

Scale with 304 Stainless Steel Column and i-DTXWE 316 Stainless Steel Indicator, Defender W Base IP67 protected

| Model | Capacity | Readability | Certified Readability | Platform Size | Item No. | List Price (USD) |
|-----------------|-----------------|------------------|-----------------------|---------------------------|----------|------------------|
| i-D61XWE2WQS6 | 5 lb / 2.5 kg | 0.0002 lb / 0.1g | 0.001 lb / 0.5g | 10 × 10 in / 254 × 254 mm | 30631706 | 1795 |
| i-D61XWE5WQS6 | 10 lb / 5 kg | 0.001 lb / 0.5 g | 0.002 lb / 1 g | 10 × 10 in / 254 × 254 mm | 30631707 | 1795 |
| i-D61XWE12WQS6 | 25 lb / 12.5 kg | 0.001 lb / 0.5 g | 0.005 lb / 5 g | 10 × 10 in / 254 × 254 mm | 30631718 | 1795 |
| i-D61XWE12WQR6 | 25 lb / 12.5 kg | 0.001 lb / 0.5 g | 0.005 lb / 5 g | 12 × 12 in / 305 × 305 mm | 30631719 | 1935 |
| i-D61XWE25WQR6 | 50 lb / 25 kg | 0.002 lb / 1 g | 0.01 lb / 5 g | 12 × 12 in / 305 × 305 mm | 30631720 | 1935 |
| i-D61XWE50WQR6 | 100 lb / 50 kg | 0.005 lb / 2 g | 0.02 lb / 10 g | 12 × 12 in / 305 × 305 mm | 30631721 | 1935 |
| i-D61XWE25WQL7 | 50 lb / 25 kg | 0.002 lb / 1 g | 0.01 lb / 5 g | 18 × 18 in / 457 × 457 mm | 30631722 | 2660 |
| i-D61XWE50WQL7 | 100 lb / 50 kg | 0.005 lb / 2 g | 0.02 lb / 10 g | 18 × 18 in / 457 × 457 mm | 30631723 | 2660 |
| i-D61XWE125WQL7 | 250 lb / 125 kg | 0.01 lb / 5g | 0.05 lb / 50 g | 18 × 18 in / 457 × 457 mm | 30631724 | 2660 |

Scale with 304 Stainless Steel Column and i-DTPW Polycarbonate Indicator, Defender W Base IP67 protected

| Model | Capacity | Readability | Certified Readability | Platform Size | Item No. | List Price (USD) |
|----------------|-----------------|------------------|-----------------------|---------------------------|----------|------------------|
| i-D61PW2WQS6 | 5 lb / 2.5 kg | 0.0002 lb / 0.1g | 0.001 lb / 0.5g | 10 × 10 in / 254 × 254 mm | 30626679 | 1570 |
| i-D61PW5WQS6 | 10 lb / 5 kg | 0.001 lb / 0.5 g | 0.002 lb / 1 g | 10 × 10 in / 254 × 254 mm | 30626680 | 1570 |
| i-D61PW12WQS6 | 25 lb / 12.5 kg | 0.001 lb / 0.5 g | 0.005 lb / 5 g | 10 × 10 in / 254 × 254 mm | 30626681 | 1570 |
| i-D61PW12WQR6 | 25 lb / 12.5 kg | 0.001 lb / 0.5 g | 0.005 lb / 5 g | 12 × 12 in / 305 × 305 mm | 30626682 | 1705 |
| i-D61PW25WQR6 | 50 lb / 25 kg | 0.002 lb / 1 g | 0.01 lb / 5 g | 12 × 12 in / 305 × 305 mm | 30626683 | 1705 |
| i-D61PW50WQR6 | 100 lb / 50 kg | 0.005 lb / 2 g | 0.02 lb / 10 g | 12 × 12 in / 305 × 305 mm | 30626684 | 1705 |
| i-D61PW25WQL7 | 50 lb / 25 kg | 0.002 lb / 1 g | 0.01 lb / 5 g | 18 × 18 in / 457 × 457 mm | 30631703 | 2415 |
| i-D61PW50WQL7 | 100 lb / 50 kg | 0.005 lb / 2 g | 0.02 lb / 10 g | 18 × 18 in / 457 × 457 mm | 30631704 | 2415 |
| i-D61PW125WQL7 | 250 lb / 125 kg | 0.01 lb / 5g | 0.05 lb / 50 g | 18 × 18 in / 457 × 457 mm | 30631705 | 2415 |

Scale with 304 Stainless Steel Front Mount and i-DTPW Polycarbonate Indicator, Defender W Base IP67 protected

| Model | Capacity | Readability | Certified Readability | Platform Size | Item No. | List Price (USD) |
|----------------|-----------------|------------------|-----------------------|---------------------------|----------|------------------|
| i-D61PW2WQS5 | 5 lb / 2.5 kg | 0.0002 lb / 0.1g | 0.001 lb / 0.5g | 10 × 10 in / 254 × 254 mm | 30631725 | 1720 |
| i-D61PW5WQS5 | 10 lb / 5 kg | 0.001 lb / 0.5 g | 0.002 lb / 1 g | 10 × 10 in / 254 × 254 mm | 30631726 | 1720 |
| i-D61PW12WQS5 | 25 lb / 12.5 kg | 0.001 lb / 0.5 g | 0.005 lb / 5 g | 10 × 10 in / 254 × 254 mm | 30631727 | 1720 |
| i-D61PW12WQR5 | 25 lb / 12.5 kg | 0.001 lb / 0.5 g | 0.005 lb / 5 g | 12 × 12 in / 305 × 305 mm | 30631728 | 1855 |
| i-D61PW25WQR5 | 50 lb / 25 kg | 0.002 lb / 1 g | 0.01 lb / 5 g | 12 × 12 in / 305 × 305 mm | 30631729 | 1855 |
| i-D61PW50WQR5 | 100 lb / 50 kg | 0.005 lb / 2 g | 0.02 lb / 10 g | 12 × 12 in / 305 × 305 mm | 30631730 | 1855 |
| i-D61PW25WQL5 | 50 lb / 25 kg | 0.002 lb / 1 g | 0.01 lb / 5 g | 18 × 18 in / 457 × 457 mm | 30572969 | 2315 |
| i-D61PW50WQL5 | 100 lb / 50 kg | 0.005 lb / 2 g | 0.02 lb / 10 g | 18 × 18 in / 457 × 457 mm | 30572970 | 2315 |
| i-D61PW125WQL5 | 250 lb / 125 kg | 0.01 lb / 5g | 0.05 lb / 50 g | 18 × 18 in / 457 × 457 mm | 30572971 | 2315 |

DEFENDER® 6000 WASHDOWN

Extreme Washdown Indicators

Display

- i-DT61XWE has a white LED with 20 mm / 0.8 in high digits and 3 color (red, green, orange) 8 x 16 dot matrix LED checkweighing/filling display.
- i-DT61PW has a white backlit LCD display with 45 mm / 1.8 in high digits. Wide 3 Color (red, green, yellow) LED Bar spans width of display for clear checkweighing results.

Communication

- i-DT61XWE has built-in RS232 and USB host, Hands-free, touchless sensor reduces contamination risk; optional 2nd RS232/RS485/USB Device, Analog Output, Wi-Fi/Bluetooth, Ethernet and Discrete I/O with relays.
- i-DT61PW can store up to 1,000 weighing results in memory for download using optional IR data connector.

Construction

i-DT61XWE: 316 Stainless Steel / i-DT61PW: Polycarbonate

Design Features

Up to 75,000d/5,000e NTEP certified and Measurement Canada approved Class III/IIHD legal-for-trade, GMP/GLP output with time/date, EasyConnect connector allows fast set-up. i-DT61XWE has hardwired internal AC power supply included—optional external USB powerbank holder available. i-DT61PW powered by 6 "D" cell batteries for up to 1,600 hours of continuous use.



Defender 6000 Extreme Indicators stand up to harsh cleaning in processing and packaging environments with IP68 immersion/ IP69K washdown protection, and 316 Stainless Steel or Polycarbonate plastic construction.

NSF certified, supporting HACCP systems with corrosion protection in food, chemical processing, and packaging.

Configurable data output with GMP/GLP and time/date for result traceability. Dedicated target key for fast item setup. i-DT61XWE includes numeric keypad and Library for up to 300 items, and can support up to 100 user profiles for easy data management.

| Model | Protection Rating | Construction | Item No. | List Price (USD) |
|--|-------------------|--|----------|------------------|
| i-DT61PW for Wall or Column Mounting | IP68 / IP69K | Polycarbonate with 316 Stainless Steel Bracket | 30575583 | 695 |
| i-DT61PW for use with Front Mount Kit 30424024 | IP68 / IP69K | Polycarbonate with 316 Stainless Steel Bracket | 30575585 | 695 |
| i-DT61XWE for Wall or Column Mounting | IP68 / IP69K | 316 Stainless Steel Housing and Bracket | 30575584 | 950 |

| Accessories | Item No. | List Price (USD) |
|--|----------|------------------|
| Wi-Fi/Bluetooth Dongle for i-DT61XWE | 30412537 | 231 |
| RS232/RS485/USB Device Kit for i-DT61XWE | 30424404 | 167 |
| Ethernet Kit for i-DT61XWE | 30429666 | 167 |
| Analog Output Kit for i-DT61XWE | 30424403 | 167 |
| Discrete I/O with Relay Kit (2 In/4 Out) for i-DT61XWE | 30097591 | 155 |
| Light Tower, 3 Colors, 243 mm, IP65 (requires 30097591) for i-DT61XWE | 30424021 | 194 |
| External Power Bank Holder, 304 Stainless Steel (requires external USB power bank) for i-DT61XWE | 30572907 | 275 |

| Accessories | Item No. | List Price (USD) |
|--|----------|------------------|
| RS232 Cable | 80500552 | 179 |
| M16 Gland with Ferrite | 30379716 | 21 |
| Alibi Memory for i-DT61XWE | 80500503 | 123 |
| 30' Loadcell Extension Cable (9 m) | 30424409 | 167 |
| IR Communication Kit for i-DT61PW only | 30572910 | 75 |
| Column Kit 10.2 in high, 316 Stainless Steel | 30572908 | 150 |
| Column Kit 26.4 in high, 316 Stainless Steel | 30572909 | 180 |
| Front Mounting Kit, 316 Stainless Steel for i-DT61PW | 30424024 | 140 |

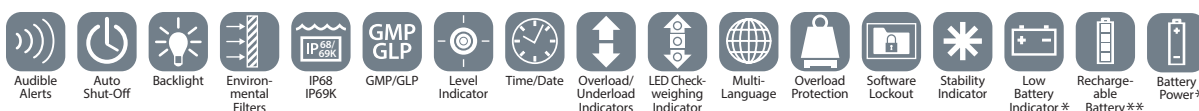
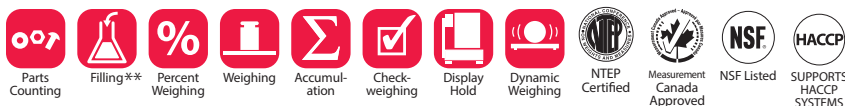

* i-DT61PW only
** i-DT61XWE only

DEFENDER® K SERIES 316 STAINLESS STEEL BASES

High Quality All Stainless Steel Base for Harsh Washdown Industrial Weighing

Construction

316 Stainless Steel base with IP68/IP69K hermetically-sealed load cell.
Pan optional on 10 × 10 in and 12 × 12 in bases.

Design Features

Up to 10,000d/5,000e NTEP certified and Measurement Canada approved Class III legal-for-trade resolution.



S and R size bases
(pan optional)

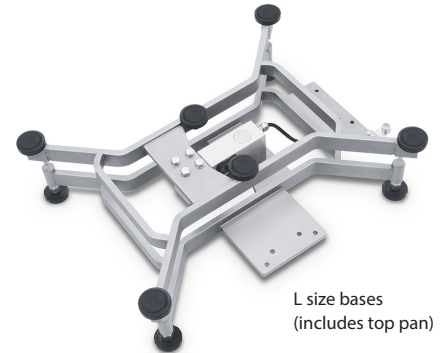

L size bases
(includes top pan)

Defender K base stands up to harsh cleaning in processing and packaging environments with 316 stainless steel construction and IP68 immersion/ IP69K washdown protected, hermetically-sealed load cell.

Durable Defender 6000 is NSF certified, supporting HACCP systems with a 316 stainless steel base providing corrosion protection in food, chemical processing, and packaging.

Includes EasyConnect module for fast connection to selected OHAUS Defender indicators (TD52XW, i-DT61XWE, i-DT61PW).

| Model | Capacity | Readability | Certified Readability | Platform Size | Item No. | List Price (USD) |
|-----------|-----------------|------------------|-----------------------|-------------------------------|----------|------------------|
| i-D5K1S | 10 lb / 5 kg | 0.001 lb / 0.5 g | 0.002 lb / 1 g | 9.8 × 9.8 in / 250 × 250 mm | 30575603 | 1090 |
| i-D12K1R | 25 lb / 12.5 kg | 0.002 lb / 1 g | 0.005 lb / 5 g | 11.8 × 11.8 in / 300 × 300 mm | 30575604 | 1170 |
| i-D25K1R | 50 lb / 25 kg | 0.005 lb / 2 g | 0.01 lb / 5 g | 11.8 × 11.8 in / 300 × 300 mm | 30575605 | 1170 |
| i-D50K1L | 100 lb / 50 kg | 0.01 lb / 5 g | 0.02 lb / 10 g | 19.7 × 15.7 in / 500 × 400 mm | 30575606 | 1475 |
| i-D150K1L | 300 lb / 150 kg | 0.02 lb / 10 g | 0.1 lb / 50 g | 19.7 × 15.7 in / 500 × 400 mm | 30575607 | 1475 |

| Accessories | Item No. | List Price (USD) |
|--|----------|------------------|
| Wheel Kit, 304 Stainless Steel | 30616409 | 167 |
| Pan 12 × 12 in, 304 Stainless Steel | 30427798 | 93 |
| Pan 10 × 10 in, 304 Stainless Steel | 30427799 | 78 |
| Column Kit 10.2 in high, 316 Stainless Steel | 30572908 | 150 |
| Column Kit 26.4 in high, 316 Stainless Steel | 30572909 | 180 |
| Front Mounting Kit, 316 Stainless Steel for i-DT61PW | 30424024 | 140 |

