

GRR Series

Guard Rail

Tools Required

2 Crescent (adjustable) Wrenches

Drill with 5/16" drill bit



Installation Instructions

Included Parts		
Item #	Description	Qty
1	Upright assembly back rail	2
2	Center upright assembly back rail	1
3	1.00 Dia horizontal tube assembly	2
4	1.25 Dia horizontal tube assembly (for bottom)	1
5	1.25 Dia horizontal tube assembly (for top)	1
6	1/4-20 x 1.50 hex cap screw	3
7	1/4-20 x 1.75 hex cap screw	6
8	1/4-20 x 2.50 hex hd cap screw	6
9	1/4-20 x 7/8 OD x .08 flat washer	6
10	1/4-20 hex lock nut	15

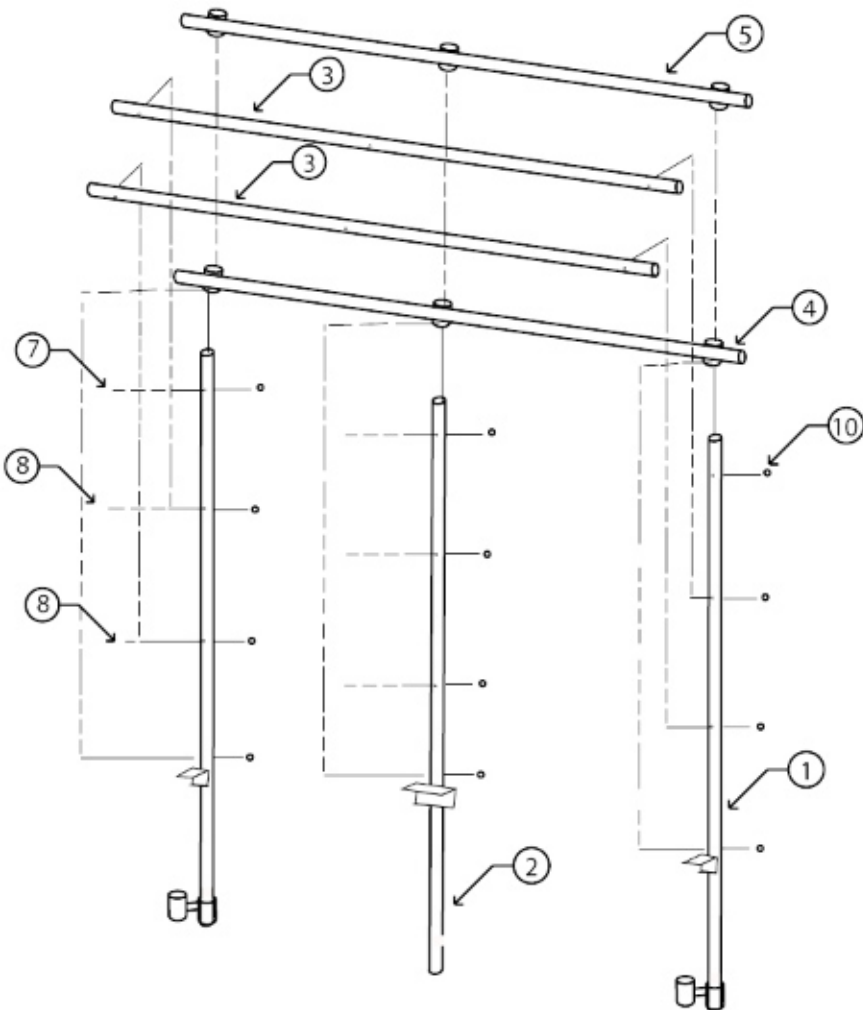

Guard rail parts

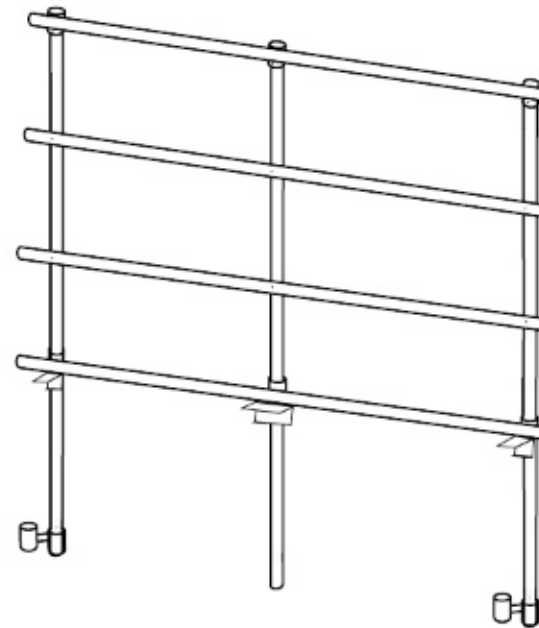

Assembled guard rail

**National Public
SEATING Corp.**

149 ENTIN ROAD, CLIFTON, NJ 07014
TEL 973-594-1100 | FAX 973-594-1500

e-mail: info@NationalPublicSeating.com

Part 1: Assemble Guard Rail (see figure 1)

Step 1: Slide tube (4) onto the 3 uprights.

Step 2: Fasten the Horizontal Tube Assemblies (3) to the uprights. The bolt should point toward the back of the unit. Use six 2.50 long bolts (8) and lock nuts (10). Tighten all six nuts and bolts using a crescent wrench.

Step 3: Fasten the 1.25 dia. Horizontal Tube Assembly (5) to the uprights. Use three 1.75 long bolts (7) and three lock nuts (10) each to fasten tube (4) and tube (5).

Part 2: Attach Guard Rail to Riser

Step 4: Align the assembled back rail with the legs of the top level of the riser set. Attach the back rail connectors to the riser set by sliding the connector over the receiver tube on the back legs (see figure 2b).

Step 5: Using a drill with a 3/8 diameter drill bit, align the drill with the leftmost edge of the slots drill a hole through the riser platform (see figure 2a). **NOTE:** Make sure the slotted brackets are securely butted against the back frame of the platform and the uprights are aligned with the legs before drilling.

Step 6: Fasten the uprights to the top of the riser set. Use three 1.50 long bolts (6), six flat washers (9), and three lock nuts (10) to attach the uprights to the riser. Leave fasteners hand-tightened until all uprights are attached. Make sure the connectors have been attached to the receivers on the back legs, as in step 4 (see figure 2c).

Step 7: Make sure all hand-tightened bolts have been tightened with a crescent wrench.

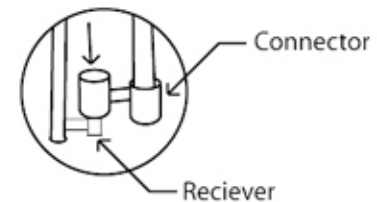

Figure 2c

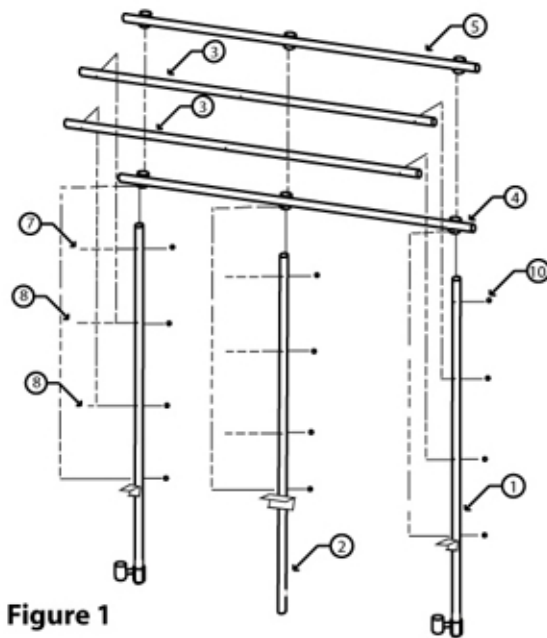

Figure 1

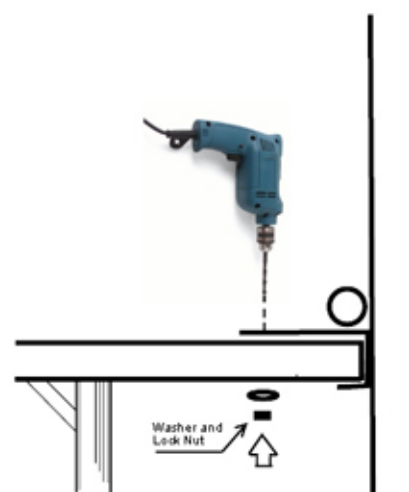

Figure 2a

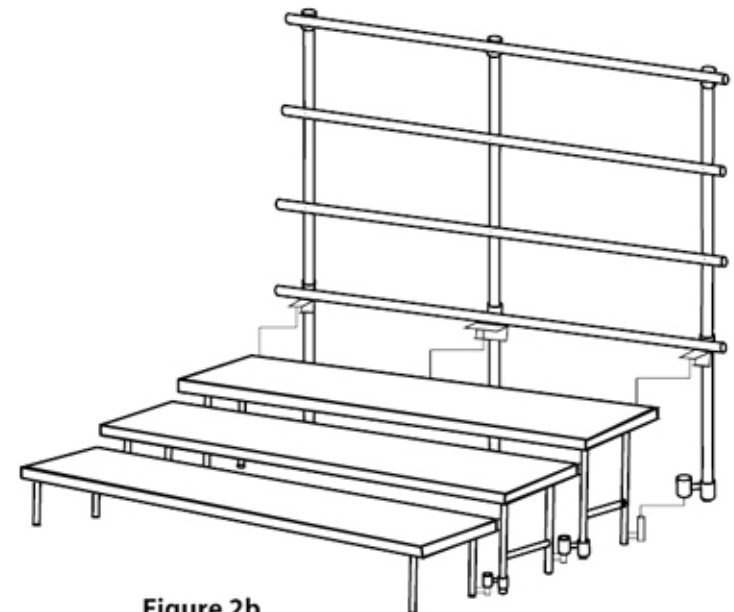

Figure 2b