

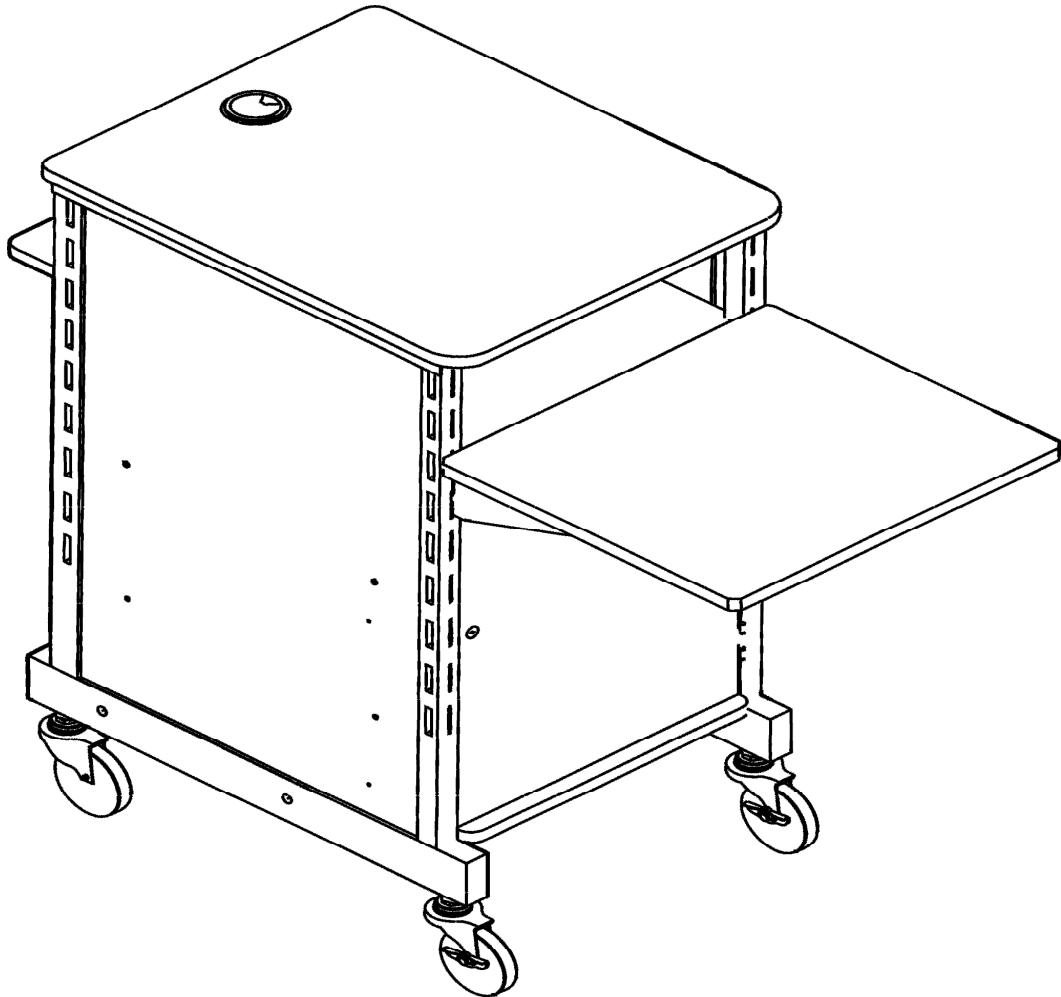

JUMBO PRESENTATION CART

PRODUCT HANDBOOK



MODEL # PRC 400*



205 Westwood Ave, Long Branch, NJ 07740
Phone: 866-94 BOARDS (26273) / (732)-222-1511
Fax: (732)-222-7088 | E-mail: sales@touchboards.com

***SEE IMPORTANT NOTICE ON PAGE #2**



Important Notice: For customers that ordered the PRC 450, first assemble this box (PRC 400) and then proceed to add the kit contained in the PRC 450 box.

Dear Valued Customer,

Although extreme care goes into manufacturing and packing of this package, mistakes are possible. If you encounter any missing parts or difficulty in assembly, etc. please call our toll free customer service line at 1-800-261-4112 for courteous and immediate resolution to your problem.

Sincerely

Oklahoma Sound

Manufactures Warranty

Our lecterns undergo the most rigid and exacting test for superior quality and performance before leaving our factory. Oklahoma Sound warrants this product to be free from defective material and workmanship on this unit for five years from the date of resale by an authorized Oklahoma Sound distributor. Oklahoma Sound will replace defective parts and repair malfunctioning products under this warranty when the defect occurs under normal installation and use, provided that the unit is returned to our factory via prepaid transportation after direct authorization and approval from Oklahoma Sound. This warranty provides that examination of the returned product must disclose in our judgment a manufacturing defect. This warranty does not extend to any product which has been subject to misuse, neglect, accident, improper installation or where the serial number has been removed if defective and is given in lieu of any other warranty implied or expressed and will not cover any damage.

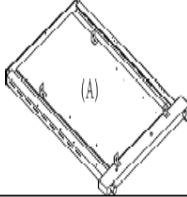
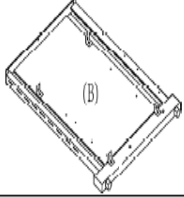
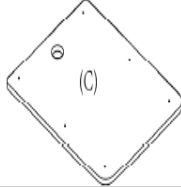
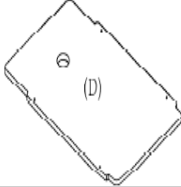
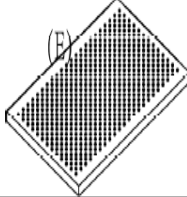
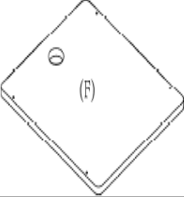
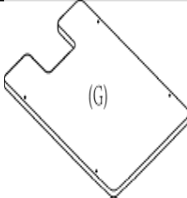
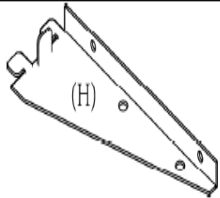
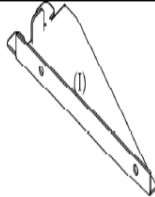
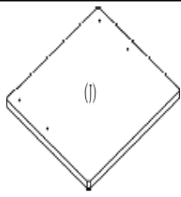
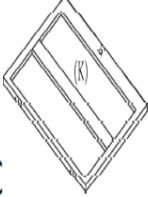
Parts List	
(A) 1PC 	(B) 1PC 
(C) 1PC 	(D) 1PC 
(E) 2PC 	(F) 1PC 
(G) 1PC 	(H) 1PC 
(I) 1PC 	(J) 1PC 
(K) 1PC 	

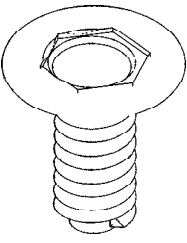
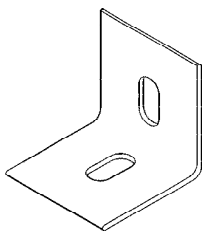
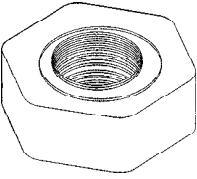
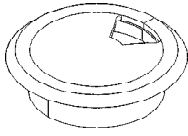
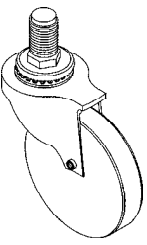
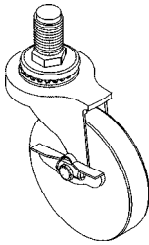
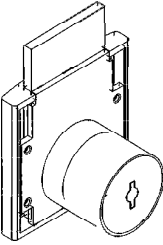
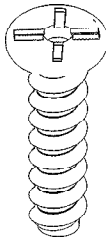
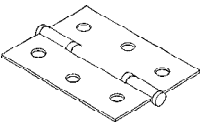
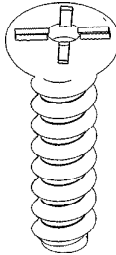
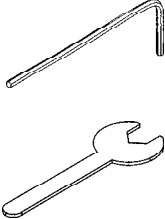
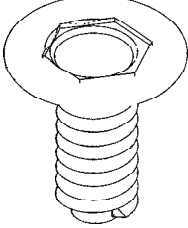
Hardware List					
(1)			(2)		
		26 pcs			4 pcs
(3)			(4)		
		4 pcs			3 pcs
(5)			(6)		
		2 pcs			2 pcs
(7)			(8)		
		1 pcs			4 pcs
(9)			(10)		
		2 pcs			12 pcs
(11)		1pcs	(13)		
		1pcs			8 pcs

Before you begin the assembly open all the panels from their individual wrapping to identify the panels properly . Be sure to open them in a way that will not scratch the panels.

Step 1:

- a) Begin by taking surface panel #C and lay it on a clean, soft surface facing down with the holes facing upwards.
- b) Locate side panels #A and B
- c) Make sure that both panels have the screw assembly tabs facing inwards as shown. Slotted edges of the side panels should be positioned on panel #C on the side opposite the grommet hole as shown.
- d) Use six bolts #1, three for each panel, to secure the side panels to the surface as shown. Screw the three bolts through the holes on the top of the side panels and into the T-nuts on panel #C.
- e) Use the provided hex key, part #11 to tighten the bolt in place.

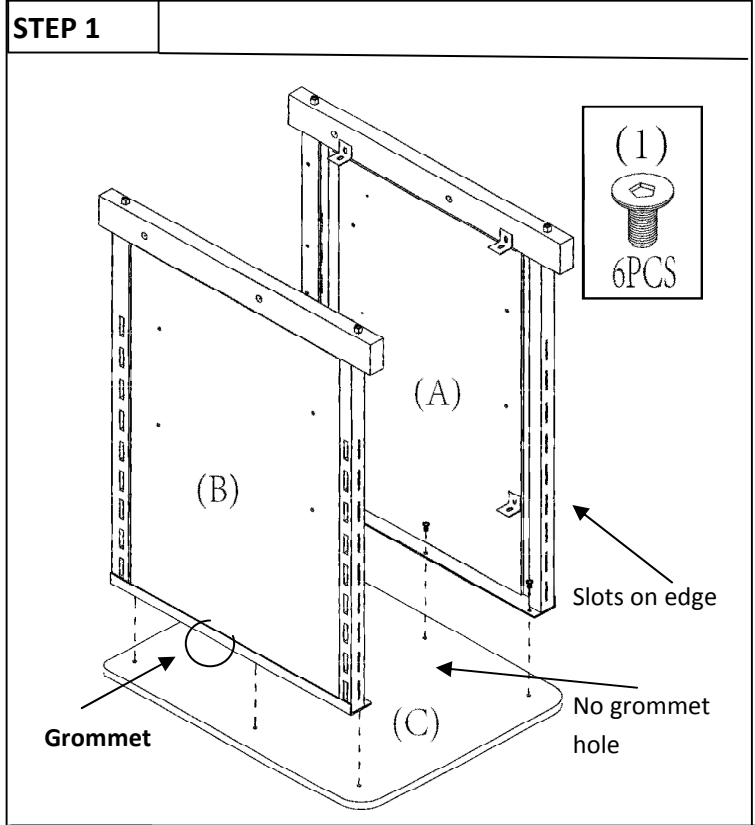

Step 2:

- a) Locate projector shelf panel #D and place it between the two side panels, just above panel #C, facing down with the embedded T-nuts facing up. Lift the panel up until the panel is flush with the four tabs on the side panels as shown.
- b) The T-nuts in the panel should be aligned with the holes in the four mounting tabs.
- c) Be sure to have shelf panel #D flush with the edges of the side panel at the slotted side of the side panels as shown. The extended end of the panel should protrude at the other end of the unit as shown,
- d) Once aligned use four bolts #13 to secure the shelf to the tabs. Screw the four bolts through the holes on the tab and into the T-nuts on panel #D.
- e)
- f) Use the provided hex key, part #11 to tighten the bolt in place.

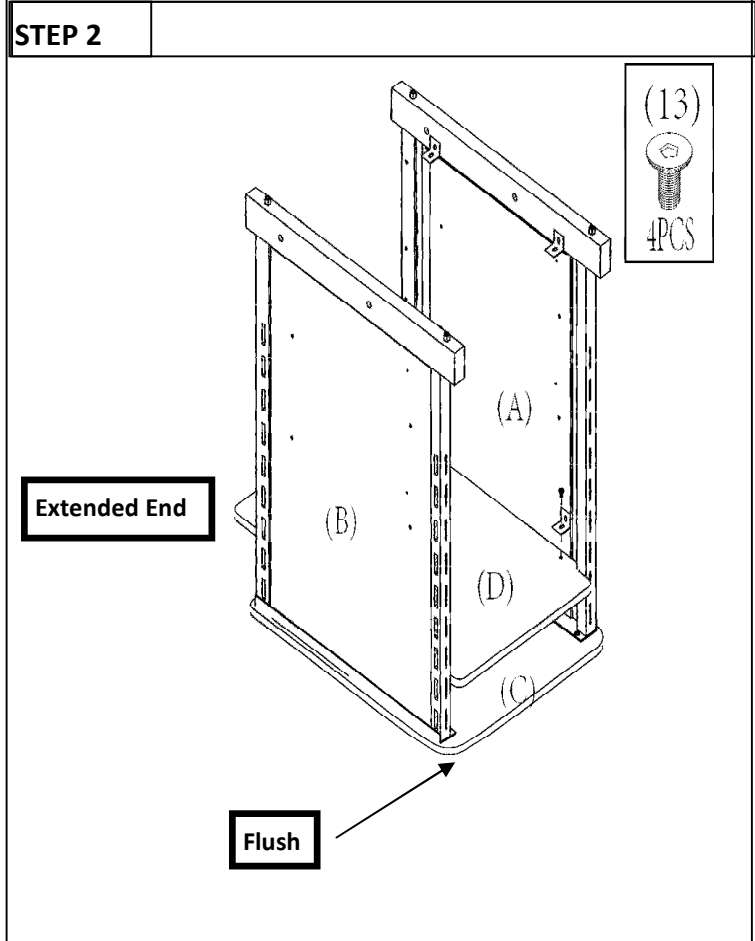

Step 3:

- a) Locate the two front metal panels part #E.
- b) The two panels will slip between the two side panels right above the projector panel #D as shown.
- c) The two panels will be mounted one on top of each other. Each of the panels has two holes at each end.
- d) Align the two holes on each end of each panel with the holes on the inside edge of the side panels.
- e) Once the holes are aligned use bolts #1 to attach panel #E to the side panel by first threading the bolt through the holes on the edge of panel #E and then into the edges of each side panel.
- f) This process should be done to attach both panels #E to the front of the unit.
- g) Use the provided hex key, part #11 to tighten the bolt in place.

STEP 3

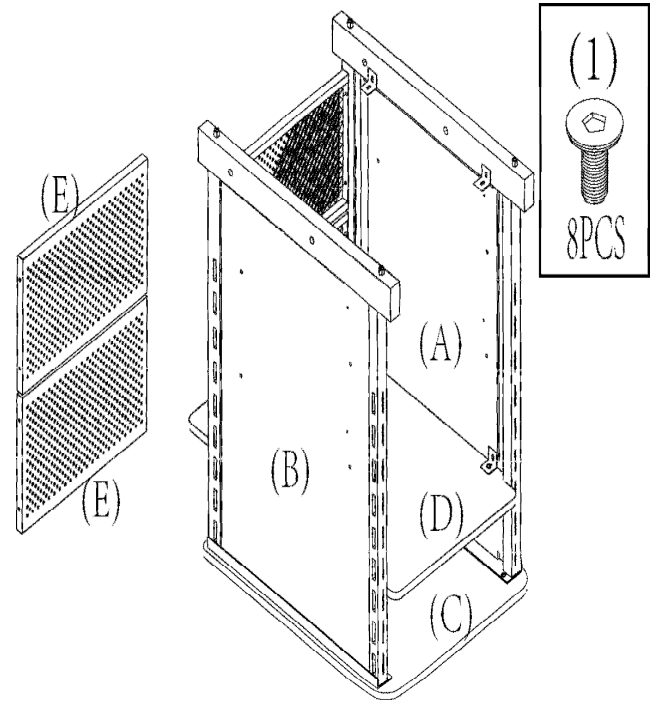

Step 4:

- a) Locate the adjustable cabinet shelf panel #F and lay it down on a clean surface facing down with the holes facing upwards.
- b) Attach four "L" brackets part #2 to the two sides of the panel as shown. Make sure that the vertical side is at the edge of the panel as shown.
- c) Use four bolts #1 to attach the brackets by inserting the bolt through the hole on the bracket and into the embedded T-nuts in the panel.
- d) Use the provided hex key, part #11 to tighten the bolt in place.

STEP 4

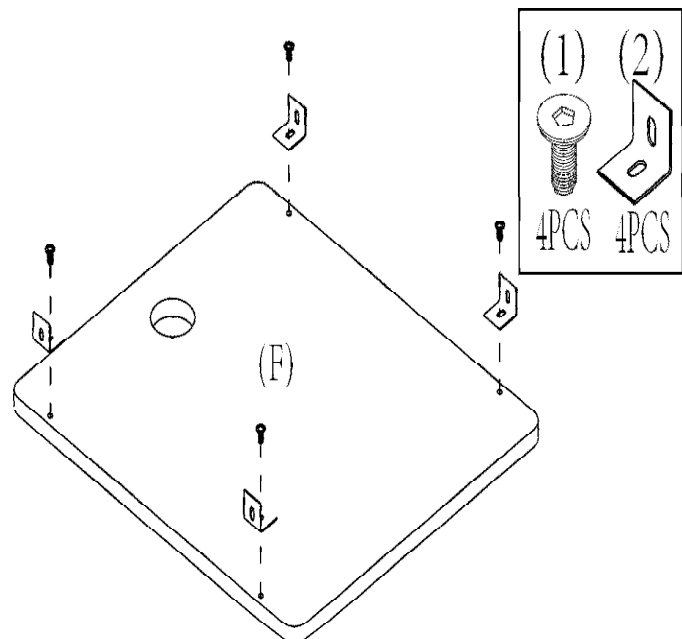

Step 5:

- a) Proceed to attach your adjustable cabinet shelf panel #F to the inside of the unit at your desired height by aligning the four brackets with the four holes on the side panel as shown.
- b) Note: There are four holes (two on each side panel) at two different heights for your preference.
- c) Once the holes on the brackets are aligned with the holes on the side panels take four bolts #1 and thread them through the hole from the outside of side panels and through the hole in the "L" bracket.
- d) Once the bolts are threaded all the way through use four nuts part #3 to secure the bolt in place.
- e) Use the provided hex key, part #20 to tighten the bolt in place.

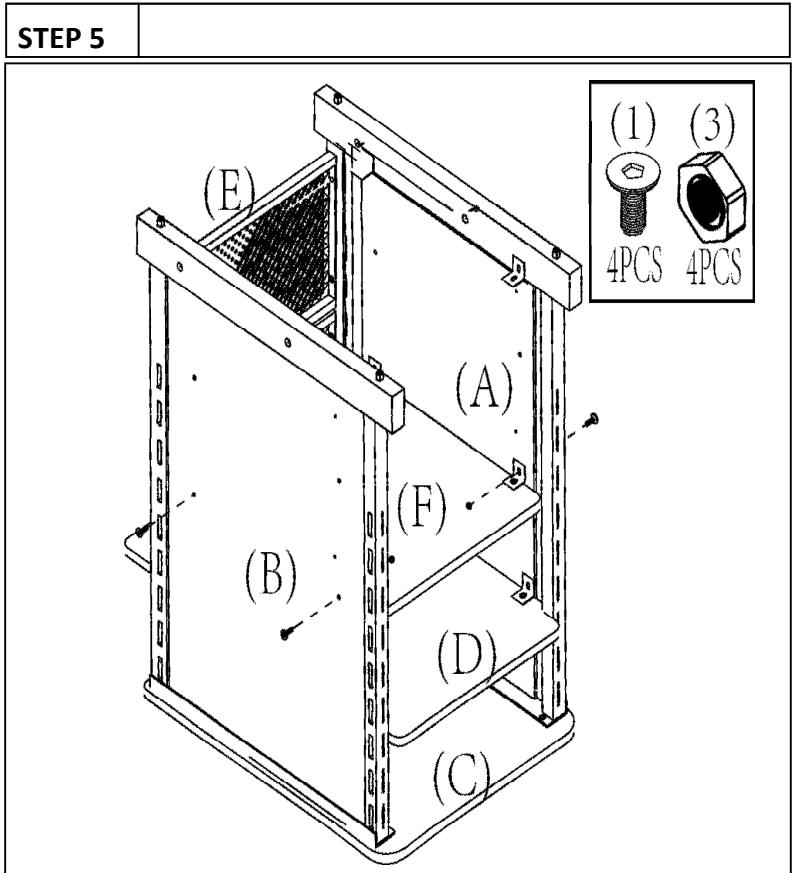

Step 6:

- a) Locate the base shelf panel #G and place it between the two side panels facing down with the embedded T-nuts aligning with the four tabs on the side panels as shown.
- b) Be sure that the side of the panel with the cut-out is close to the back of the unit up against panels #E as shown.
- c) Lift the panel up until the panel is flush with the four tabs, two on each of the side panels as shown
- d) Once aligned use four bolts #13 to secure the shelf to the tabs.
- e) Use the provided hex key, part #11 to tighten the bolt in place

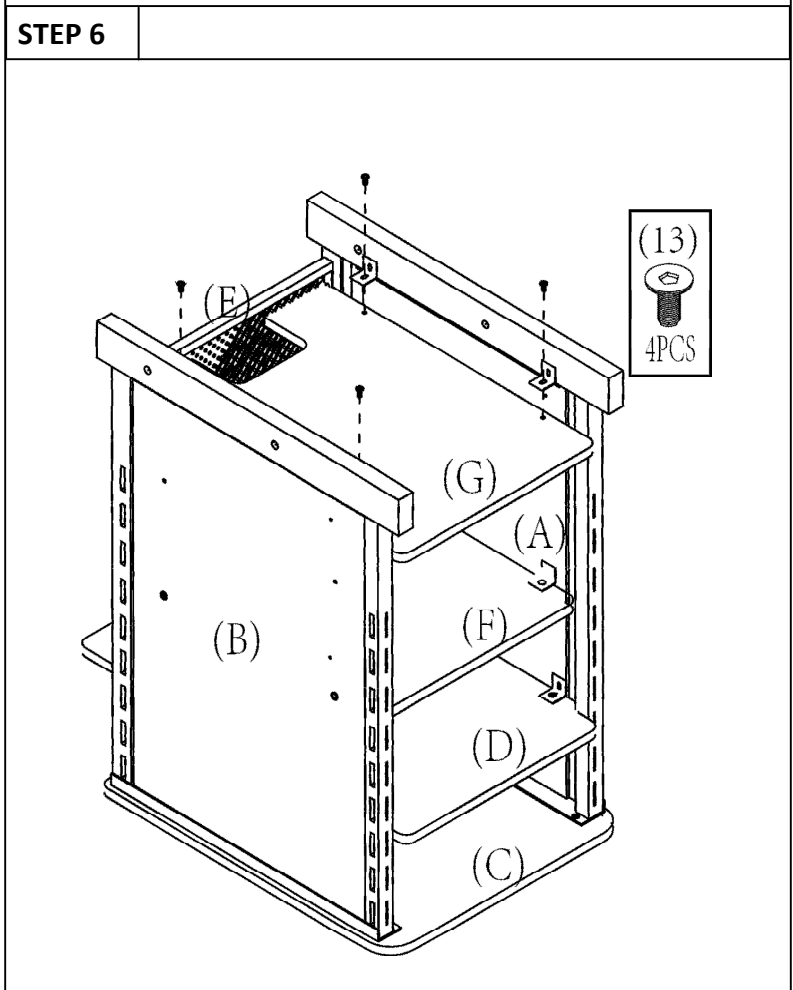

Step: 7:

- a) Identify the four casters wheels, two locking part #6 and two non –locking, part #5.
- b) Be sure to attach the two locking casters #6 at the correct side of the unit as shown in the illustration, for easier access to the brakes while operating the cart.
- c) Thread the stems of the casters through cast-er nuts located at each corner as shown.
- d) Use the open wrench part #12 to tighten the caster to the unit.
- e) Repeat the above step to attach the non-locking casters #5 to the other two caster nuts located at the other end of the unit.

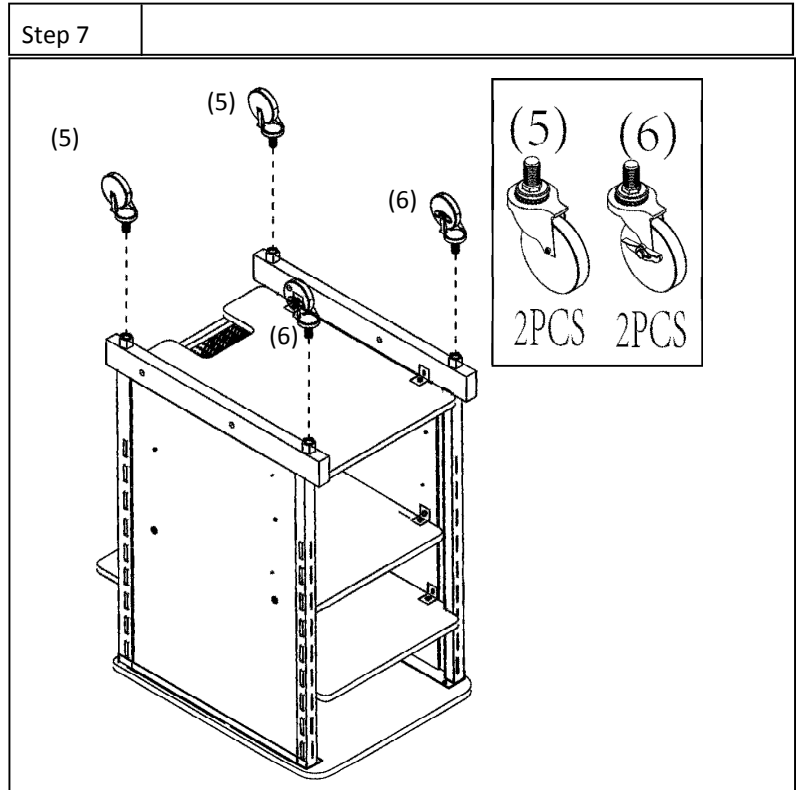

Step 8:

- a) Locate the door panel #K.
- b) Proceed to install the lock assembly #7, by inserting the barrel part of the lock from the inside of the panel as shown.
- c) Be sure that the tongue of the lock is facing the edge of the panel as shown.
- d) Use four screw #8 to attach the lock mounting plate to the panel. One screw in every corner of the mounting plate as shown.
- e) Place the black ring around the barrel of the lock from the outside of the panel with the spikes slipping between the barrel and the door panel.

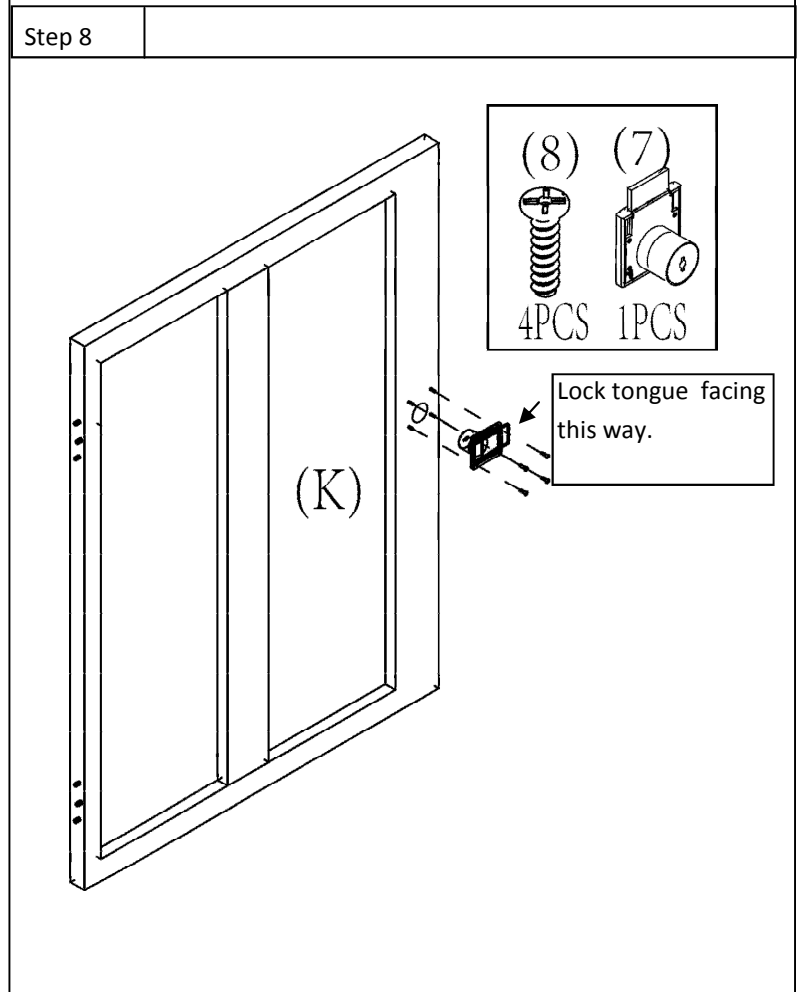

Step 9:

- a) Gently turn the unit right side up and lock the casters so the unit will not roll during assembly.
- b) Identify the two hinges part #9. Align the three holes on the left part of the hinge over the three holes on the edge of side panel #B. The right side of the hinge should be on the outside of the unit.
- c) Be sure that the hinges are placed with the barrel of the hinge facing inwards.
- d) Once the hinges are in the correct position, use three screws #10 to attach each hinge to the side panel. Repeat this process for both upper and lower hinge.
- e) Once the hinges are secured in place, hold up the door panel #K in the open 90 degree position as shown, and align the six holes on the edge of the panel with the holes on the right part of each hinge.
- f) Once the six holes of the hinges are aligned to the six holes on the side of the door panel #K, use six screw #10 to attach the right part of hinges part #9 to the door panel #K as shown.

Step 10:

- a) Identify panel #J and lay it on a clean, soft surface facing down with the holes facing upwards.
- b) Locate the two supporting brackets #H and #I and lay them over the panel as shown. The two tabs at the end of the bracket should be at the edge of the panels as shown.
- c) The two brackets should be facing inwards as shown.
- d) Align the two holes on the brackets with the embedded t-nuts in the panel
- e) Once they are aligned use four bolts #1, two for each bracket and thread them through the holes on the bracket and into the t-nut.
- f) Use the hex key to tighten the bolts .

Step 11:

- a) To attach the adjustable shelf #J to your unit, align the two tabs on each bracket with the slots on the edge of each side panel. One aligned slip them in and gently push the shelf downwards to lock in place.
- b) Locate the three grommets part #4 and insert them into the surface shelf, projector shelf and adjustable cabinet shelf.

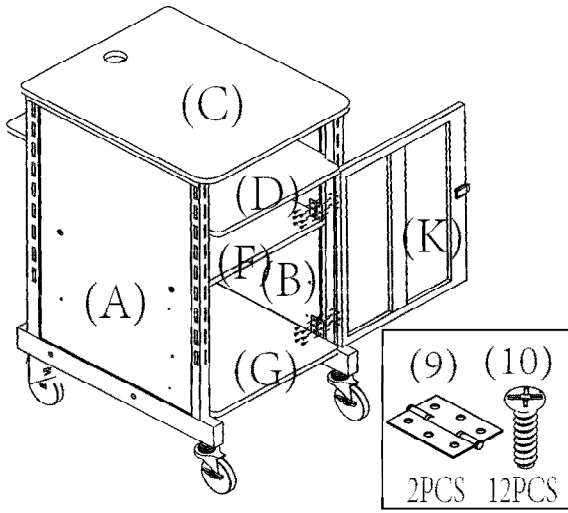
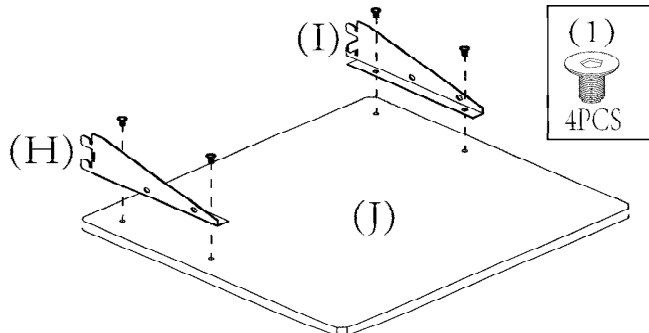
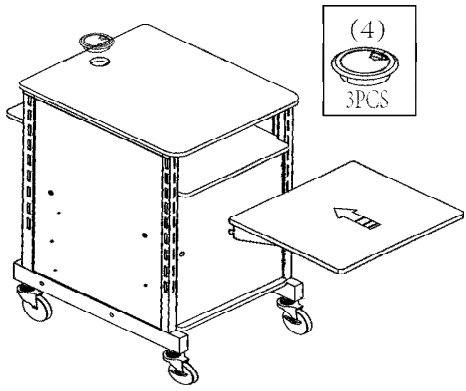
STEP 9	
STEP 10	
STEP 11	

Congratulations!!! Your PRC 400 is now fully assembled!!

Other Sound and Non-Sound Lecterns from Oklahoma Sound

Model #WZD



Model #612

Model #LSS



MODEL #111 PLS

Model #SCL



For these and other OS product please contact your dealer, or:

Oklahoma Sound

149 Entin Road, Clifton N.J. 07014 ♦ Tel : (973) 594-9000

www.oklahomasound.com ♦ info@oklahomasound.com