

Online Interfaces and Optional Features

- Fully implement predictive diagnostics to improve plant availability and reduce maintenance costs
- Gain enhanced information and diagnostic functionality
- Add new features and interfaces as your needs change

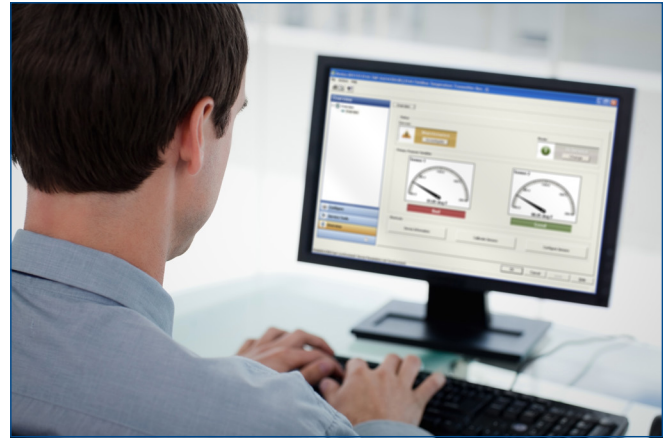

AMS Device Manager provides predictive diagnostics to improve plant reliability and reduce maintenance costs.

AMS Device Manager

AMS Device Manager provides access to predictive diagnostics and real-time field device information to improve reliability and performance. Reduce time required to troubleshoot, configure, and calibrate field devices to more effectively deploy your maintenance resources and improve operations efficiency.

You can also automatically document your maintenance activities to eliminate errors from manual reporting to create an audit-ready plant.

Optional features and interfaces include:

- Emerson Host System Interfaces: DeltaV™, Ovation™, PROVOX™, RS3™, OpenEnterprise™
- ABB System 800xA Interface
- Audit Trail
- Calibration Assistant SNAP-ON™ application with Smart Documenting Calibrator Interface
- FOUNDATION™ fieldbus High Speed Ethernet Interface
- Det-Tronics EQP Interface
- Handheld Communicator Interface
- HART® Multiplexer Interface
- HART Over PROFIBUS Interface
- Integration Tools
- Kongsberg Maritime Interface
- Smart Wireless Interface
- Third Party PROFIBUS

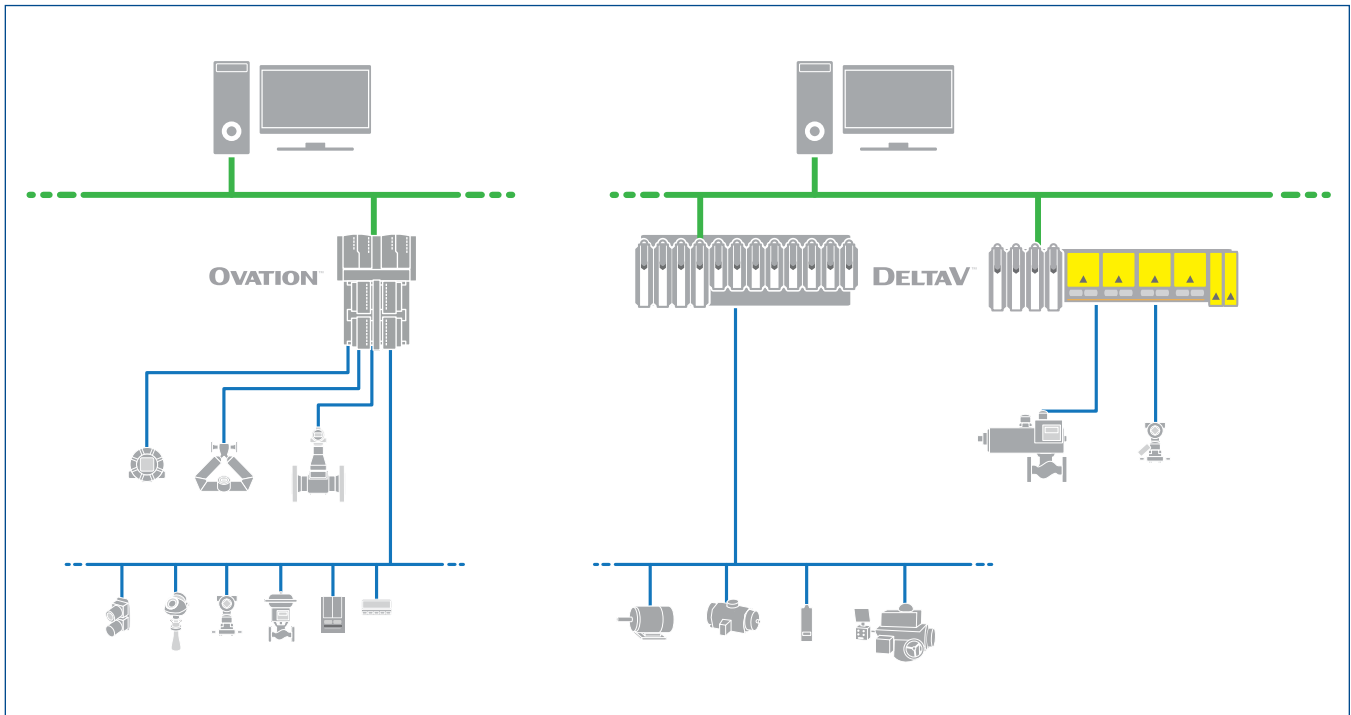

Using AMS Device Manager with a DeltaV or Ovation control system enables you to access important predictive diagnostics.

Licensed Options Extend Asset Management Capabilities

Extend the reach of your AMS Device Manager system by adding licensed options that meet the needs of your plant.

Audit Trail

Audit Trail provides historical records of device configuration changes and performance.

You can view records based on tag or serial number. Each record allows you to look at the changes for a specific device, the reason for the change, and who performed it. Audit Trail records can be used to help meet process safety requirements. All records are date- and time-stamped and have a user/PC correlation. To ensure data integrity, historical records cannot be edited.

Integration Tools

Integration Tools enables the OPC Server in AMS Device Manager, which allows OPC Client applications to access device data in the database or directly from the device. Integration Tools also enables the XML Web Services to interface device information with third-party applications.

Host System Interfaces

DeltaV System

AMS Device Manager and the DeltaV system work together to deliver a user interface in an integrated operating environment for HART, FOUNDATION fieldbus, IEC-approved WirelessHART®, PROFIBUS DP, and PROFIBUS PA devices.

The DeltaV system passes field device data through the controller to AMS Device Manager without the need for extra hardware or wiring to provide a comprehensive asset management solution.

Ovation System

AMS Device Manager with Ovation provides a seamless interface with HART, FOUNDATION fieldbus, PROFIBUS DP, and WirelessHART protocols, allowing you easy access to smart device diagnostics.

OpenEnterprise System Interface

The OpenEnterprise System Interface gives you the power to extend AMS Device Manager beyond plant walls to remote sites hundreds or thousands of miles away. Connect AMS Device Manager to a OpenEnterprise network of ROC800, FloBoss107, and ControlWave RTUs to view, configure, and diagnose remote HART and WirelessHART devices.

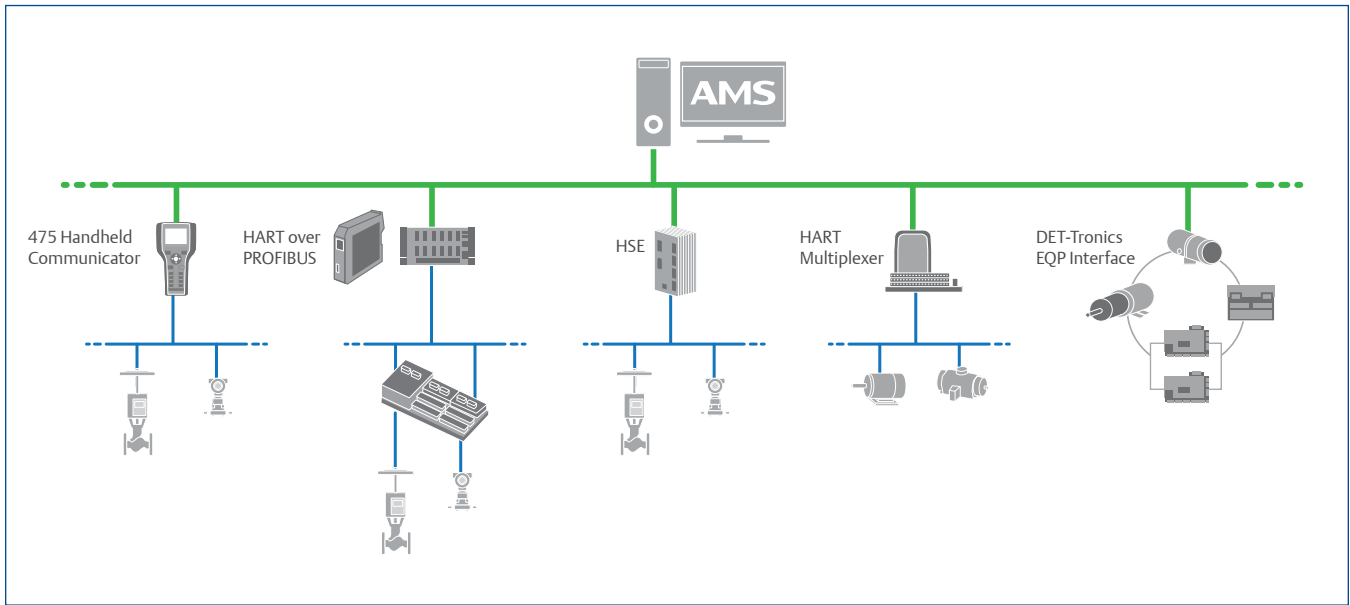

AMS Device Manager supports a variety of interfaces to make it easy to access your device diagnostics.

RS3 System

AMS Device Manager accesses HART data already available to your RS3 system, passing field data to your AMS Device Manager network.

PROVOX System

The PROVOX system allows you to access the predictive diagnostics of your intelligent field devices through AMS Device Manager, delivering dependable control solutions for both continuous process and batch industries.

Handheld Communicator Interface

The Handheld Communicator Interface enables you to transfer HART device configuration information and synchronize information between your AMS Device Manager database and a 475 Field Communicator.

With this interface, you can drag-and-drop configurations to your handheld communicator and upload the information from the device back to AMS Device Manager. From AMS Device Manager, you can print the device configuration data.

HART Multiplexer Interface

The HART Multiplexer Interface allows you to access real-time HART device diagnostics in AMS Device Manager while using a legacy or third-party host system. Connect AMS Device Manager to a multiplexer to gain fast access to all your HART devices, regardless of the host.

Det-Tronics EQP Interface

With the Det-Tronics EQP Interface, you can easily access the status of fire and gas detectors. Quickly check the health of any connected detector and receive alerts when a condition is detected within the EQP system.

HART Over PROFIBUS Interface

The HART Over PROFIBUS Interface enables you to use AMS Device Manager with HART devices in an online environment with a PROFIBUS network. Gain the full benefit of AMS Device Manager without the additional costs of multiplexer installation and wiring.

High Speed Ethernet (HSE) Interface

The HSE Interface helps you to realize the benefits of FOUNDATION fieldbus devices, even if your current control system does not support fieldbus. Use AMS Device Manager with fieldbus linking devices to configure and diagnose your fieldbus devices from a single application. The HSE Interface also supports connectivity to FOUNDATION fieldbus ROC and ControlWave networks.

Third Party PROFIBUS Interface

Using a Softing linking device, connect to PROFIBUS DP and PA devices through third part host systems. Gain access to online diagnostics and easy configuration capabilities via AMS Device Manager. With this interface, you have a single application for maintenance of your HART, FOUNDATION fieldbus, and PROFIBUS devices.

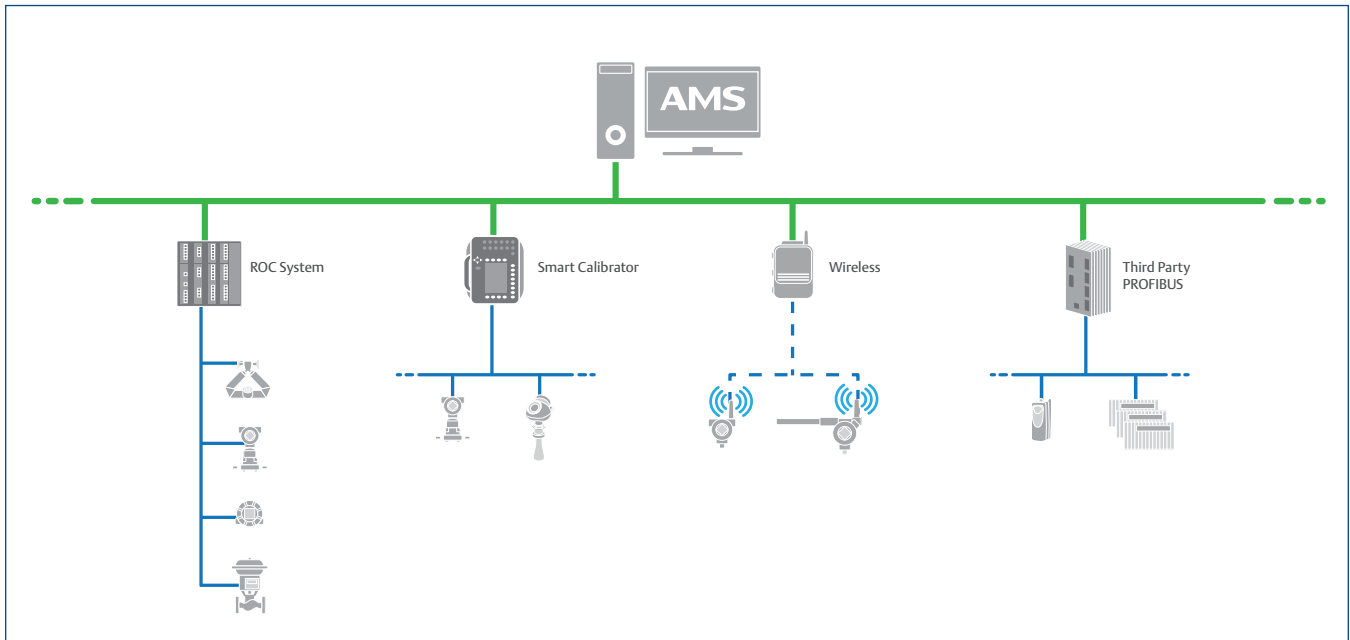

Gain access to predictive device diagnostics with AMS Device Manager interfaces.

Kongsberg Maritime Interface

The Kongsberg Maritime Interface allows you to work with offshore oil and gas applications. Connect AMS Device Manager to the Kongsberg Maritime control system for online connectivity to offshore HART devices. This connectivity delivers real-time predictive device diagnostics to the onshore control room. Eliminate the need for personnel to visit the platform to access device information, saving time and improving safety.

ABB System 800xA Interface

The ABB System 800xA Interface allows you to connect an AMS Device Manager system to the ABB System 800xA control system. Use data from the ABB 800xA system to configure, calibrate, and manage your HART devices with AMS Device Manager.

Smart Calibrator Interface

AMS Device Manager interfaces with documenting calibrators through the Calibration Assistant SNAP-ON application to manage the calibrations of HART, FOUNDATION fieldbus, and conventional devices. Transfer data between your calibrator and AMS Device Manager to eliminate manual records and the possibility of errors. You can automatically check As-Found/ As-Left information into AMS Device Manager, allowing you to keep accurate, organized calibration records right at your fingertips.

Wireless Interface

The Wireless Interface provides easy access to your WirelessHART devices via the Emerson Wireless Gateway. With the Wireless Interface, you can view predictive diagnostics in devices that were once out of physical or economic reach. Use AMS Device Manager for remote configuration and diagnostics without the additional expense of multiplexer installation and wiring.

Lifecycle Services

Get off to a strong start with your technology investment. Use Emerson's Lifecycle Services to ensure you are effectively employing AMS Device Manager. Emerson can help you use the diagnostics from your smart devices to full advantage.

Our experts will:

- Design and execute an optimized maintenance strategy for a new or existing facility.
- Install the applications and complete your initial configurations.

- Implement re-engineered maintenance tasks to optimize your use of AMS Device Manager with your smart devices, while integrating data with your enterprise asset management system to enable measurement of improvement to your facility's bottom line.

Contact your local Emerson sales representative for more information.

©2018, Emerson. All rights reserved.

The Emerson logo is a trademark and service mark of Emerson Electric Co. AMS, DeltaV, Ovation, SNAP-ON, RS3, and PROVOX are marks of one of the Emerson family of companies. All other marks are the property of their respective owners.

The contents of this publication are presented for informational purposes only, and while every effort has been made to ensure their accuracy, they are not to be construed as warranties or guarantees, express or implied, regarding the products or services described herein or their use or applicability. All sales are governed by our terms and conditions, which are available on request. We reserve the right to modify or improve the designs or specifications of our products at any time without notice.

Emerson
Reliability Solutions
12001 Technology Drive
Eden Prairie, MN 55344 USA
www.emerson.com/ams