

POWER CORD LOCATION

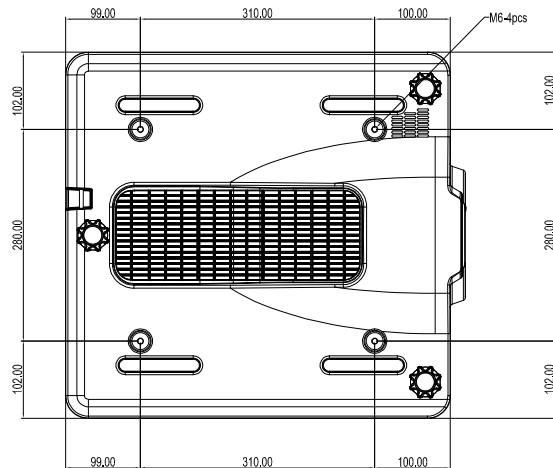

GENERAL NOTE

1.MASS: 21.0 Kg (No Lens)

2.OPERATING TEMPERATURE RANGE:

0°C~40°C @ 0~2500FT

0°C~35°C @ 2500~5000FT

0°C~30°C @ 5000~10000FT

REV		DATE		BY		CHK		APP		PART No.		REV	
1													
2													
3													
4													
5													
6													
7													
8													
9													
10													
11													
12													
13													
14													
15													
16													
17													
18													
19													
20													
21													
22													
23													
24													

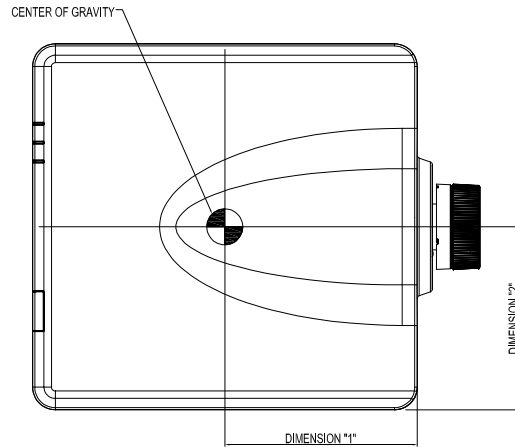

CENTER OF GRAVITY

LENS TYPE	DESCRIPTION	DIMENSION '1'	DIMENSION '2'	DIMENSION '3'
BX-CAA01	Optional Lens (TR:0.95-1.22)	241	222	74
BX-CAA03	Optional Lens (TR:1.52-2.89)	241	222	74
BX-CAA06	Standard Lens (TR:1.22-1.52)	241	222	74
BX-CTA13	Optional Lens (TR:2.9-5.5)	241	222	74
BX-CTA15	Optional Lens (TR:0.75-0.95)	241	222	74
BX-CTA16	Optional Lens (TR:0.361_under 120°)	223	223	76
BX-CTA17	Optional Lens (TR:0.65-0.75)	241	222	74
WITHOUT PROJECTION LENS		243	222	73

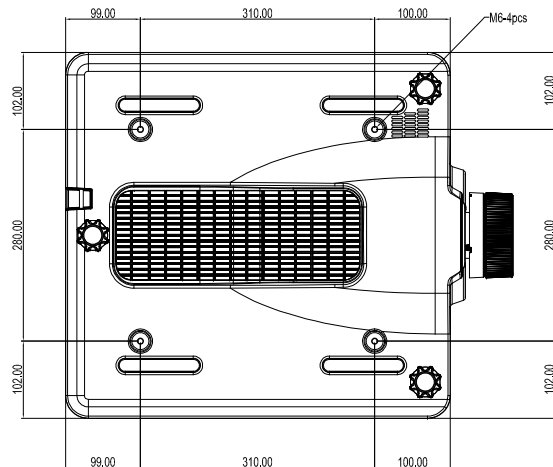
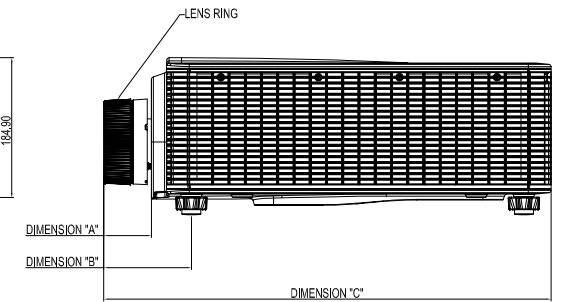
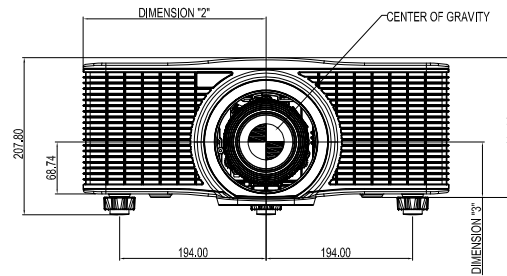
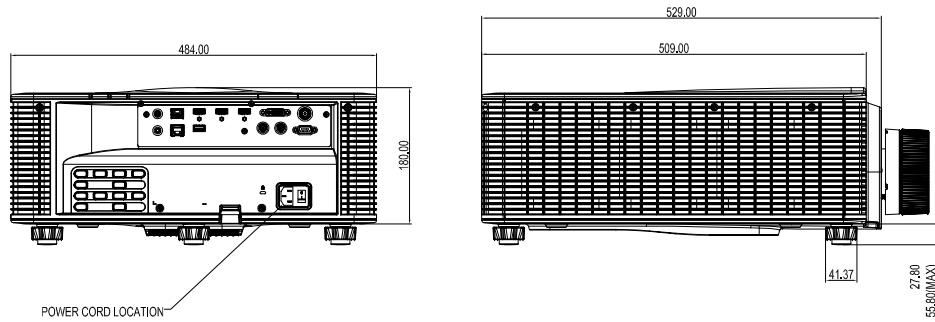
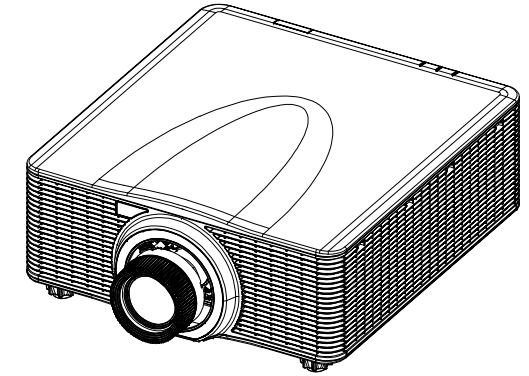

PROJECTOR DIMENSIONS WITH PROJECTION LENS

LENS TYPE	DESCRIPTION	DIMENSION 'A'	DIMENSION 'B'	DIMENSION 'C'	LENS DIA	LENS RING
BX-CAA01	Optional Lens (TR:0.95-1.22)	43.3	96.3	572.3	Ø86	YES
BX-CAA03	Optional Lens (TR:1.52-2.89)	63.1	116.1	592.1	Ø86	YES
BX-CAA06	Standard Lens (TR:1.22-1.52)	62.6	115.6	591.6	Ø89	YES
BX-CTA13	Optional Lens (TR:2.9-5.5)	90.8	143.8	619.8	Ø86	YES
BX-CTA15	Optional Lens (TR:0.75-0.95)	50.7	103.7	579.7	Ø104	YES
BX-CTA16	Optional Lens (TR:0.361_under 120°)	297.2	350.2	626.2	250	N/A
BX-CTA17	Optional Lens (TR:0.65-0.75)	84.8	137.8	613.8	Ø146	N/A

GENERAL NOTE

1.MASS: 21.0 Kg (No Lens)

2.OPERATING TEMPERATURE RANGE:

0°C-40°C @ 0-2500FT

0°C-35°C @ 2500-5000FT

0°C-30°C @ 5000-10000FT

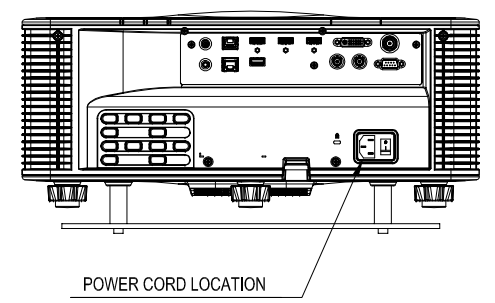
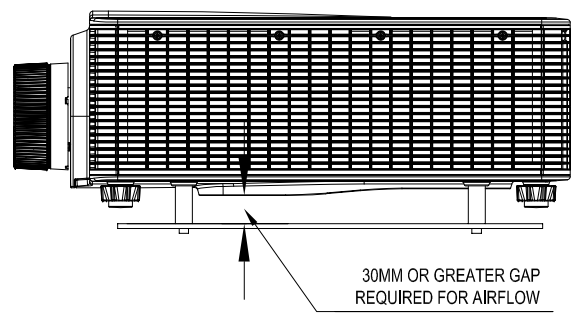
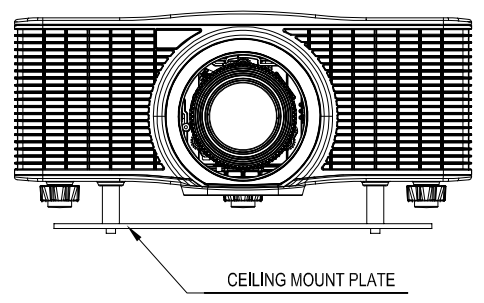
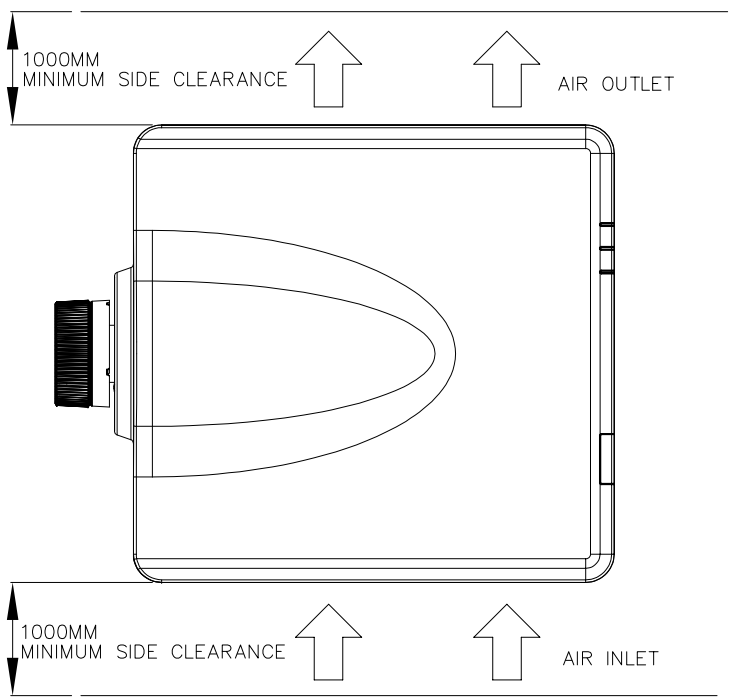

REVISIONS		DATE	BY	CHKD	APP'D	REASON
1	Initial Release					
2	Minor Revision					
3	Major Revision					
4	Minor Revision					
5	Minor Revision					
6	Minor Revision					
7	Minor Revision					
8	Minor Revision					
9	Minor Revision					
10	Minor Revision					
11	Minor Revision					
12	Minor Revision					
13	Minor Revision					
14	Minor Revision					
15	Minor Revision					
16	Minor Revision					
17	Minor Revision					
18	Minor Revision					
19	Minor Revision					
20	Minor Revision					
21	Minor Revision					
22	Minor Revision					
23	Minor Revision					
24	Minor Revision					
25	Minor Revision					

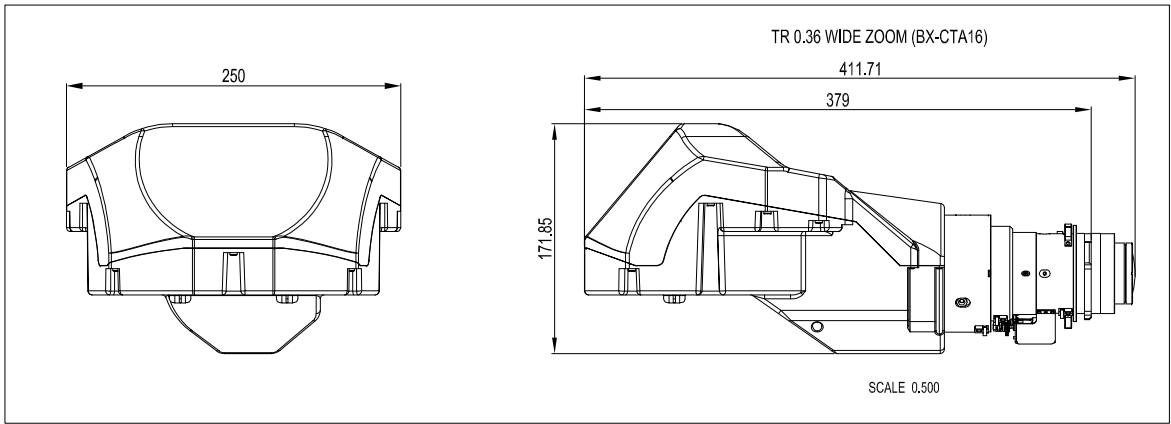

TR 1.22 - 1.52 STANDARD ZOOM (BX-CAA06)

TR 1.52 - 2.92 LONG ZOOM (BX-CAA03)

TR 0.95 - 1.22 WIDE ZOOM (BX-CAA01)

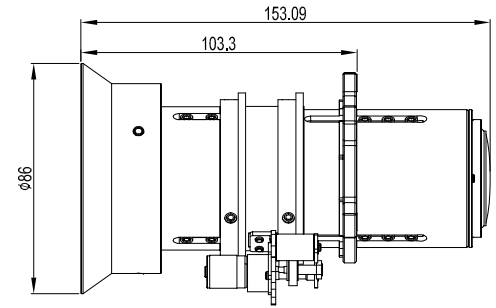
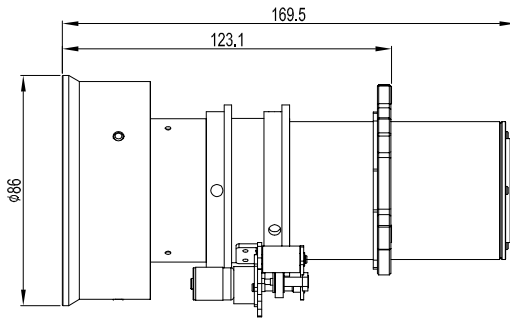
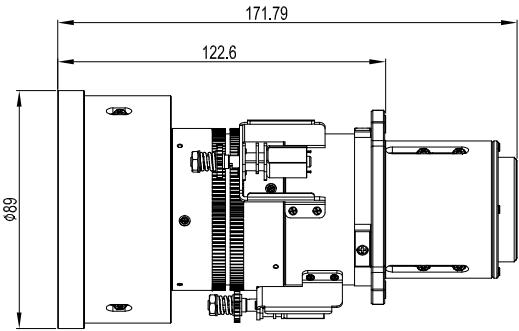

TR 0.65 - 0.75 WIDE ZOOM (BX-CTA17)

TR 0.75 - 0.95 WIDE ZOOM (BX-CTA15)

TR 2.90 - 5.50 LONG ZOOM (BX-CTA13)

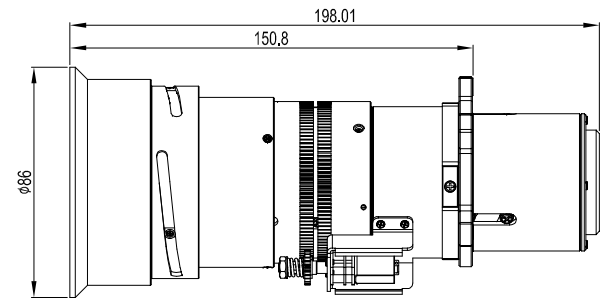
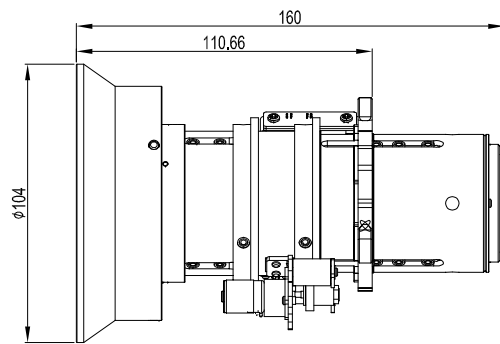
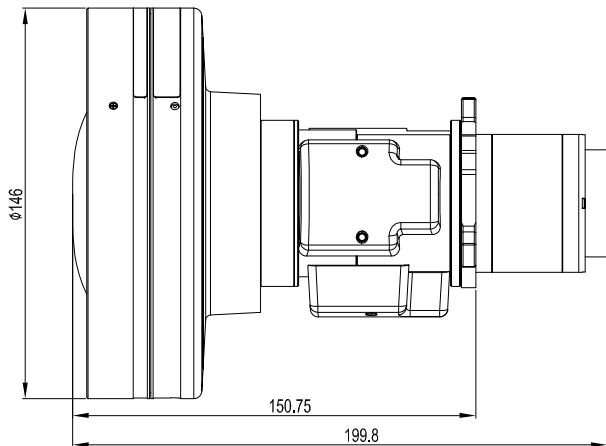

DESCRIPTION	GROSS WEIGHT	NET WEIGHT
Optional Lens BX-CAA01 (TR 0.95-1.22)	0.8 kg	0.8 kg
Optional Lens BX-CAA03 (TR 1.52-2.92)	1.18 kg	0.8 kg
Standard Lens BX-CAA06 (TR 1.22-1.52)	1.32 kg	0.8 kg
Optional Lens BX-CTA13 (TR 2.90-5.50)	1.4 kg	1.0 kg
Optional Lens BX-CTA15 (TR 0.75-0.95)	1.18 kg	0.7 kg
Optional Lens BX-CTA16 (TR 0.36)	7.95 kg	2.7 kg
Optional Lens BX-CTA17 (TR 0.65-0.75)	1.8 kg	1.17 kg

Rev.	Author	Date	Description	ECR. NO.	DATE	DESCRIPTION	DATE	DESCRIPTION	DATE	DESCRIPTION

UNITS UNLESS OTHERWISE NOTED	CMR.	NAME :
mm		

ITEM NO.	QTY	UNIT	DESCRIPTION	REVISION

DATE	BY	CHKD	APPD

SCALE	UNIT	DATE	DESCRIPTION



A1