

*Projector*

***PH3501QL/PH2601QL***

***powered by NP-LV01BD***

---

*Installation Manual*

NEC Display Solutions, Ltd.

Model No.

NP-PH3501QL, NP-PH2601QL, NP-PH3501QL+, NP-PH2601QL+, NP-LV01BD

# Introduction

---

This manual describes the procedures for mounting the NP-LV01BD mandatory option kit onto the NEC PH3501QL/PH2601QL projector, as well as installation, connections and adjustments. For safe and correct installation, adjustment and maintenance of the projector, carefully read this document before considering the layout of the unit and installation. Please keep this document under care by the company who installed or adjusted the projector. This document is intended the readers who have basic knowledge about projector installation. Refer to the user's manual of an applicable projector for basic operation and remarks.

## The product name used in this manual

In this manual, the device name is written as listed below. If the function has difference by devices, the product name is written in the text.





PH3501QL/PH2601QL: This product or the projector  
NP-LV01BD: LV unit

- DLP® and the DLP logo are trademarks or registered trademarks of Texas Instruments in the United States and other countries.
- Other product and company names mentioned in this user's manual may be the trademarks or registered trademarks of their respective holders.
- Illustrations shown in this manual may differ slightly from the actual ones.

## NOTES

- (1) The contents of this manual may not be reprinted in part or whole without permission.
- (2) The contents of this manual are subject to change without notice.
- (3) Great care has been taken in the preparation of this manual; however, should you notice any questionable points, errors or omissions, please contact us.
- (4) Notwithstanding article (3), NEC will not be responsible for any claims on loss of profit or other matters deemed to result from using the Projector.

# Important Information

	This symbol warns the user that uninsulated voltage within the unit may have sufficient magnitude to cause electric shock. Therefore, it is dangerous to make any kind of contact with any part inside of this unit.
	This symbol alerts the user that important literature concerning the operation and maintenance of this unit has been included. Therefore, it should be read carefully in order to avoid any problems.
	This symbol indicates something that must be prohibited.
	This symbol indicates something that must not be broken down.
	This symbol indicates something that must be paid attention to.

 <b>CAUTION</b>
TO PREVENT ELECTRIC SHOCK, DO NOT OPEN TOP COVER. NO USER SERVICEABLE PARTS INSIDE.

## Laser Safety Caution

This product is classified as Class 1 of IEC60825-1 Third edition 2014. This product is classified as RG3 of IEC62471-5 First edition 2015. This product is classified as RG3 of IEC62471:2006 (for USA). Obey the laws and regulations of your country in relation to the installation and management of the device.

 <b>CAUTION</b>
Use of controls or adjustments of procedures other than those specified herein may lead to hazardous laser radiation exposure.

- Hazardous optical radiation is emitted from this product, RG3 IEC 62471:2006 (for USA).
- No direct exposure to the beam shall be permitted, RG3 IEC 62471-5:2015.

## Do not do it

- Do not look into the lens while the projector is on. Serious damage to your eyes could result.



- Keep any items such as magnifying glass out of the light path of the projector. The light being projected from the lens is extensive, therefore any kind of abnormal objects that can redirect light coming out of the lens, can cause unpredictable outcome such as fire or injury to the eyes.
- When turning on the projector, ensure that nobody is facing towards the lens in the path of the light emitted from the laser.

## DOC Compliance Notice (for Canada only)

This Class A digital apparatus meets all requirements of the Canadian ICES-003 Standards.

## Machine Noise Information Regulation - 3. GPSGV,

The highest sound pressure level is less than 70 dB (A) in accordance with EN ISO 7779.

 <b>WARNING</b>
This equipment is compliant with Class A of CISPR 32. In a residential environment this equipment may cause radio interference.

### CAUTION

In order to reduce any interference with radio and television reception use a signal cable with ferrite core attached. Use of signal cables without a ferrite core attached may cause interference with radio and television reception.

This equipment has been tested and found to comply with the limits for a Class A digital device, pursuant to Part 15 of the FCC Rules. These limits are designed to provide reasonable protection against harmful interference when the equipment is operated in a commercial environment. This equipment generates, uses, and can radiate radio frequency energy and, if not installed and used in accordance with the installation manual, may cause harmful interference to radio communications. Operation of this equipment in a residential area is likely to cause harmful interference in which case the user will be required to correct the interference at his own expense.

### WARNING



#### Do not disassemble

THE END USER IS NOT ALLOWED TO OPEN OR MODIFY THE PRODUCT.  
NO USER SERVICEABLE PARTS.  
MAINTENANCE AND SERVICE OF THE PRODUCT IS ONLY TO BE HANDLED BY NEC AUTHORIZED TECHNICIANS.

## Important Safeguards

These safety instructions are to ensure the long life of your projector and to prevent fire and shock. Please read them carefully and heed all warnings.

### Installation

1. Do not point the projection beam toward other people or reflective objects.
2. Consult your distributor for information about transporting and installing the projector. Do not attempt to transport and install the projector yourself. The projector must be installed by qualified technicians in order to ensure proper operation and reduce the risk of bodily injury.
3. Place the projector on a flat, level surface in a dry area away from dust and moisture. Do not put the projector on its side when the Laser is on. Doing so may cause damage to the projector.
4. Do not place the projector in direct sunlight, near heaters or heat radiating appliances.

5. Exposure to direct sunlight, smoke or steam could harm internal components.
6. Handle your projector carefully. Dropping or jarring your projector could damage internal components.
7. To carry the projector, a minimum of six persons are required. Be sure to firmly grip the front and back handles, then move the projector.
8. Do not hold the lens part with your hand. Otherwise the projector may tumble or drop, causing personal injury.
9. Do not place heavy objects on top of the projector.
10. Turn off the projector, and disconnect the power cable before moving the projector.  
For C2 connection, turn off the projector, shut down the AC power to the projector and the light using a circuitbreaker. Disconnect the cables between devices and the light before moving the projector.
11. Do not install and store the projector in the below circumstances. Failure to do so may cause of malfunction.
  - In powerful magnetic fields
  - In corrosive gas environment
  - Outdoors
12. If you need special installation work such as mounting on the ceiling or suspending from the ceiling using eye bolts:
  - Do not attempt to install the projector yourself.
  - The projector must be installed by qualified technicians in order to ensure proper operation and reduce the risk of bodily injury.
  - In addition, the ceiling must be strong enough to support the projector and the installation must be in accordance with any local building codes.
  - If you hang the projector from the high place such as the ceiling, use fall prevention wires (commercially available) to secure the lens unit in place. Failing to do so may result in the lens unit being loosened, causing it to fall.
  - Make sure if the projector is fixed on the surface that has enough durability to stand the whole projector weight (the projector weight including LV unit 170 kg plus the lens weight 9 kg, i.e., 179 kg in total) for a long time.
  - Please consult your distributor for more information.

### WARNING



#### Do not do it

1. Do not use the projector with the supplied lens cap or equivalent while the projector is operating. This may cause the lens cap to heat up and deform or melt.
2. Do not place any objects, which are easily affected by heat, in front of the projector lens. Doing so could lead to the object melting from the heat that is emitted from the light output.



It is possible to vertically set up this device at 360 degrees. Do not use the projector with it leaning to the left and right. This may result in a malfunction, however, portrait installation is possible. Please read the warnings concerning portrait orientation before setting the projector in portrait orientation.

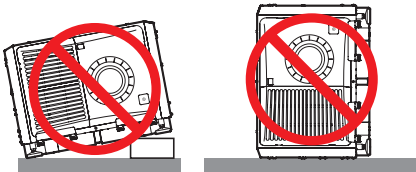

## Power Supply

1. Consult your distributor for installing the power cable to the projector. **DO NOT** install the power cable by yourself. Doing so may cause a fire or electric shock. The projector is so designed that it operates with the power supply voltage described below.  
For C1 connection  
(When the AC power to the projector power supply and the light power supply is provided by a single cable)
  - AC 200V-240V single phase 50/60HzFor C2 connection  
(When the AC power to the projector power supply and the light power supply is provided by separate cables)
  - AC 200V-240V single phase 50/60Hz (projector power supply)
  - AC 200V-240V single phase 50/60Hz (light power supply)Ensure that your power supply fits this requirement before attempting to use your projector.
2. The power cable is not included with the projector. Ask your distributor for the power cable to select and purchase. Use a power cable that meets the standards and power supply voltage of the country where you are using the projector.  
Refer to “1-8. Connecting the Power Cable” (→ page 24) for details on connecting the power cable.

3. Handle the power cable carefully. A damaged or frayed power cable can cause electric shock or fire.
  - Do not bend or tug the power cable excessively.
  - Do not place the power cable under the projector, or any heavy object.
  - Do not cover the power cable with other soft materials such as rugs.
  - Do not heat the power cable.
4. Placing the power cable and the signal cable closely to each other can cause beat noise. If this happens, keep the two separated so that beat noise is not generated.  
Beat noise is corruption of the picture often seen as a rolling band moving through the image.
5. Do not touch the projector during a thunder storm. Doing so can cause electrical shock or fire.
6. When installed on the ceiling, install the breaker in a location that is easy to reach by hand.

### CAUTION

This equipment is designed to be used in the condition of the power cable connected to earth. If the power cable is not connected to the earth, it may cause electric shock. Please make sure the power cable is earthed properly.

**Fire and Shock Precautions**

1. Ensure that there is sufficient ventilation and that vents are unobstructed to prevent potentially dangerous concentrations of ozone and the build-up of heat inside your projector. Allow at least 23.6 inches (60 cm) of space between your projector and a wall. In particular, clear a space of 27.6 inches (70 cm) or more in front of the air outlet on the rear surface and 11.8 inches (30 cm) or more on the upper part of the projector body. (→ page 1)
2. Prevent foreign objects such as paper clips and bits of paper from falling into your projector. Do not attempt to retrieve any objects that might fall into your projector. Do not insert any metal objects such as a wire or screwdriver into your projector. If something should fall into your projector, shut down the AC power to the projector immediately and have the object removed by a qualified service person.  
For C2 connection, turn off the projector, shut down the AC power to the projector and the light using a circuit breaker, and contact your dealer/distributor.
3. Turn off the projector, shut down AC power by using a circuit breaker and contact qualified service personnel under the following conditions. For C2 connection, turn off the projector, shut down the AC power to the projector and the light using a circuit breaker, and contact your dealer/distributor for a repair.
  - When the power cable or plug is damaged or frayed.
  - If liquid has been spilled into the projector, or if it has been exposed to rain or water.
  - If the projector does not operate normally when you follow the instructions described in this user's manual.
  - If the projector has been dropped or the cabinet has been damaged.
  - If the projector exhibits a distinct change in performance, indicating a need for service.
4. When using a LAN cable:  
For safety, do not connect to the connector for peripheral device wiring that might have excessive Voltage.
5. Make sure to mount the power cable stopper before attempting to use your projector. Refer to page 36 about the power cable stopper.

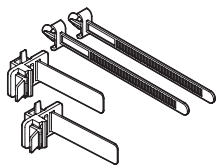

**Cleaning**

1. Shut down AC power by using a circuit breaker before cleaning.  
For C2 connection, turn off the projector, shut down the AC power to the projector and the light using a circuit breaker.
2. Clean the cabinet periodically with a cloth. If heavily soiled, use a mild detergent. Never use strong detergents or solvents such as alcohol or thinner.
3. Use a blower or lens paper to clean the lens, and be careful not to scratch or mar the lens.
4. Do not handle the projector and the power cable with wet hands. Doing so can cause electrical shock or fire.
5. Do not use a spray containing flammable gas to remove dust attached to the lens and cabinet. Doing so may result in fires.

 **CAUTION**

 **Do not do it**

1. Do not shut down AC power to the projector under the following conditions. Doing so can damage the projector.
  - While projecting images
  - While cooling after the power is turned off.
2. Do not turn off the AC power for 90 seconds after the Laser is turned on and while the POWER indicator is blinking green. Doing so could cause premature Laser failure.
3. Keep hands away from the lens mounting portion while the lens shift is in operation. Failure to do so could result in fingers being pinched between the cabinet and lens cover.
4. When main body is damaged, cooling fluids may come out of internal part. **DO NOT** touch and drink the cooling fluid.  
When the cooling fluids are swallowed or contacted with your eyes, please consult with doctors immediately.

### Caution on Carrying the Projector/ Handling the Optional Lens

When installing / removing a lens, shut down the AC power to the projector.

When shipping the projector with the lens, remove the lens before shipping the projector. Always attach the dust cap to the lens whenever it is not mounted on the projector. The lens and the lens shift mechanism may encounter damage caused by improper handling during transportation.

### Cable information

#### CAUTION

For HDMI, DisplayPort, BNC, LAN, RS232C, 3D, and GP I/O, please use a shielded cable.

Use of other cables may cause interference with radio and television reception.

### Remote Control Precautions

- Handle the remote control carefully.
- If the remote control gets wet, wipe it dry immediately.
- Avoid excessive heat and humidity.
- Do not short, heat, or take apart batteries.
- If you will not be using the remote control for a long time, remove the batteries.
- Ensure that you have the batteries' polarity (+/-) aligned correctly.
- Do not use new and old batteries together, or use different types of batteries together.

### Handling the Battery

- Take care when handling the battery, as it could cause fire, injury, or damage to surrounding objects.
  - Do not short out, dismantle, or place batteries in a fire.
- Dispose of used batteries according to your local regulations.
- There is a battery mounted on the electronic circuit board within the main unit. When disposing of the main unit, do not dismantle the device or remove the internal circuit board, and contact the shop where you purchased the product or your local government agency.

### Light Module

1. A light module containing multiple laser diodes is included in the product as the light source.
2. These laser diodes are sealed in the light module. No maintenance or service is required for the performance of the light module.
3. End user is not allowed to replace the light module.
4. Contact qualified distributor for light module replacement and further information.

### Disposing of your used product



EU-wide legislation as implemented in each Member State requires that used electrical and electronic products carrying the mark (left) must be disposed of separately from normal household waste.

This includes projectors and their electrical accessories. When you dispose of such products, please follow the guidance of your local authority and/or ask the shop where you purchased the product.

After collecting the used products, they are reused and recycled in a proper way. This effort will help us reduce the wastes as well as the negative impact to the human health and the environment at the minimum level.

The mark on the electrical and electronic products only applies to the current European Union Member States.



**For EU:** The crossed-out wheeled bin implies that used batteries should not be put to the general household waste! There is a separate collection system for used batteries, to allow proper treatment and recycling in accordance with legislation.

**According to EU directive 2006/66/EC, the battery can't be disposed improperly. The battery shall be separated to collect by local service.**

Label Information

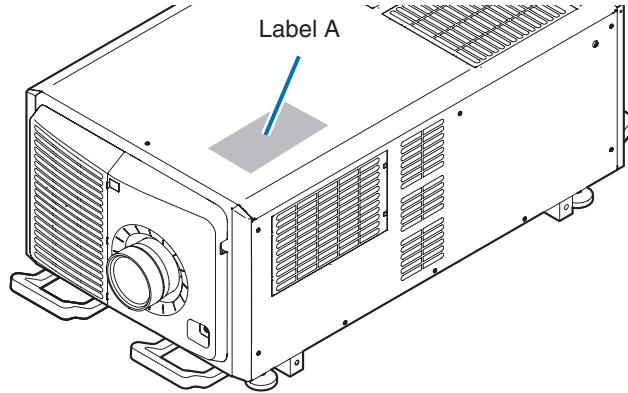

Label A: Risk Group /Lamp Safety Label



**RISK GROUP 3**  
**WARNING**  
 DO NOT LOOK INTO THE BEAM.  
 NO DIRECT EYE EXPOSURE TO THE BEAM IS PERMITTED.  
 HAZARD DISTANCE: REFER TO THE MANUAL.

**GROUPE DE RISQUE 3**  
**AVERTISSEMENT**  
 NE PAS REGARDER DIRECTEMENT DANS LE FAISCEAU.  
 L'EXPOSITION DIRECTE DES YEUX AU FAISCEAU EST INTERDITE.  
 DISTANCE À RISQUE: SE REPORTER AU MANUEL.

**RISIKOGRUPPE 3**  
**WARNUNG**  
 SCHAUEN SIE NICHT IN DEN STRAHL.  
 DIREKTER AUGENKONTAKT MIT DEM STRAHL IST NICHT ERLAUBT.  
 SICHERHEITSABSTAND: SIEHE HANDBUCH.

**ГРУППА РИСКА 3**  
**ПРЕДУПРЕЖДЕНИЕ**  
 НЕ СМОТРИТЕ НА ЛУЧ.  
 ЗАПРЕЩАЕТСЯ ЛЮБОЕ ПРЯМОЕ ВОЗДЕЙСТВИЕ ЛУЧА НА ГЛАЗА.  
 ОПАСНОЕ РАСТОЯНИЕ: СМ. РУКОВОДСТВО ПО ЭКСПЛУАТАЦИИ.

**リスクグループ 3**  
**警告**  
 ビームを見ないこと。  
 目へのビームの直接曝露を禁止する。  
 障害距離: 取扱説明書を参照。

**위험 그룹 3**  
**경고**  
 빔을 눈으로 보지 마십시오.  
 빔을 직접 눈에 노출하는 것은 허용되지 않습니다.  
 위험 거리: 설명서를 참조하십시오.

**风险组别 3**  
**警告**  
 请勿注视光束。  
 不允许将眼睛暴露于光束中。  
 有害距离: 请参阅手册。  
 IEC/EN 62471-5:2015

**FOR NORTH AMERICA**  
**RISK GROUP 3**  
**WARNING**  
 HAZARDOUS OPTICAL RADIATION EMITTED FROM THIS PRODUCT.  
 DO NOT LOOK AT OPERATING LIGHT SOURCE.  
 EYE INJURY MAY RESULT.  
 HAZARD DISTANCE: REFER TO THE MANUAL.  
 NO DIRECT EXPOSURE TO BEAM SHALL BE PERMITTED.  
 NOT FOR HOUSEHOLD USE.

**GROUPE DE RISQUE 3**  
**AVERTISSEMENT**  
 RADIATIONS OPTIQUES DANGEREUSES EMISES PAR CE PRODUIT.  
 NE REGARDER PAS DIRECTEMENT LA SOURCE LUMINEUSE.  
 CELA POURRAIT ENTRAÎNER DES BLESSURES AUX YEUX.  
 DISTANCE À RISQUE: SE REPORTER AU MANUEL.  
 L'EXPOSITION DIRECTE AU RAYON DOIT ÊTRE AUTORISÉE.  
 NE CONVIENT PAS À UN USAGE DOMESTIQUE.

IEC/TR 62471-2:2009  
 IEC/EN 62471:2006



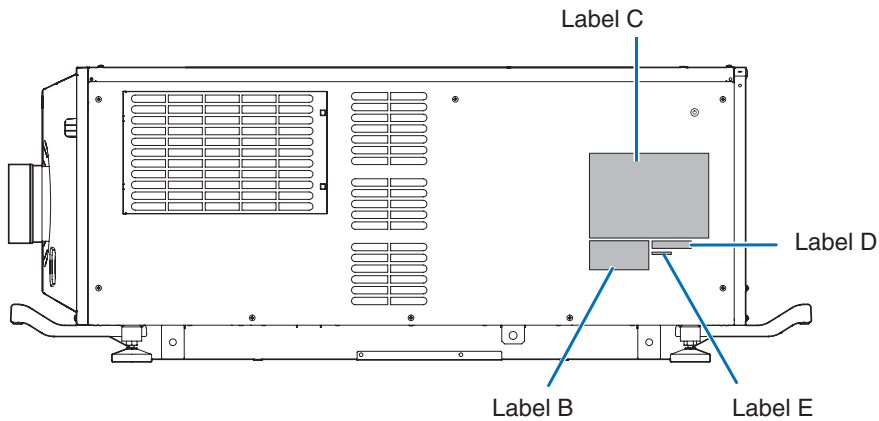

Label B  
Laser Explanatory Label



Label C  
PH3501QL

**NEC** MODEL No. NP-PH3501QL C1: 200-240V ~ 50/60Hz 30.0A  
 C2: 200-240V ~ 50/60Hz 4.9A for PJ POWER  
 200-240V ~ 50/60Hz 25.1A for LIGHT POWER

CE

NEC Display Solutions, Ltd. 4-28, Mita 1-chome, Minato-ku, Tokyo, Japan  
 Contact address for EMEA NEC Display Solutions Europe GmbH Landshuter Allee 12-14 80637 Munich, Germany  
 Tegangan dan Frekuensi: C1: 200-240V ~ 50/60Hz C2: 200-240V ~ 50/60Hz(PROYEKTOR CATU DAYA) 200-240V ~ 50/60Hz(CAHAYA CATU DAYA) Produksi China

MADE IN CHINA THIS CABINET IS CONSTRUCTED OF METAL(AL)

	<b>警告</b> 高压注意
	サービスマン以外の方は外装パネルを外さないでください。内部には高電圧部分が数多くあり、カーさわると危険です。

**使用上の注意**  
 イ. 通風孔をふさがないでください。内部温度の上昇を招き故障の原因になります。  
 ロ. 温度の高い場所や湿気の多い場所での使用はさけてください。

**CAUTION:** TO PREVENT ELECTRIC SHOCK, DO NOT OPEN TOP COVER. NO USER-SERVICEABLE PARTS INSIDE.  
**ATTENTION:** AFIN DE PREVENIR UN CHOC ELECTRIQUE NE PAS ENLEVER LE COUVERCLE S'ADRESSER A UN REPARATEUR COMPETENT.  
**ВНИМАНИЕ:** ВО ИЗБЕЖАНИЕ УДАРА ЭЛЕКТРИЧЕСКИМ ТОКОМ НЕ ОТКРЫВАЙТЕ ВЕРХНЮЮ КРЫШКУ. ВНУТРИ НЕТ ДЕТАЛЕЙ, ОБСЛУЖИВАЕМЫХ ПОЛЬЗОВАТЕЛЕМ.  
**주의:** 전기충격 방지를 위해 캐비닛을 열지 마십시오. 내부에는 사용자를 위한 서비스가능 부품이 들어있지 않습니다.  
**ACHTUNG:** Zur Vermeidung eines elektrischen Schlages, öffnen Sie das Gehäuse nicht selbst. In diesem Gerät sind keine Teile enthalten, die vom Nutzer gewartet werden können.

この装置は、クラス A 機器です。この装置を住宅環境で使用すると電波妨害を引き起こすことがあります。この場合には使用者が適切な対策を講ずるよう要求されることがあります。 VCCI-A

THIS DEVICE COMPLIES WITH PART 15 OF THE FCC RULES, OPERATION IS SUBJECT TO THE FOLLOWING TWO CONDITIONS:  
 (1) THIS DEVICE MAY NOT CAUSE HARMFUL INTERFERENCE, AND  
 (2) THIS DEVICE MUST ACCEPT ANY INTERFERENCE RECEIVED, INCLUDING INTERFERENCE THAT MAY CAUSE UNDESIRE OPERATION. CAN ICES-3(A)/NMB-3(A)

Label C  
PH2601QL

**NEC** MODEL No. NP-PH2601QL C1: 200-240V ~ 50/60Hz 30.0A  
 C2: 200-240V ~ 50/60Hz 4.9A for PJ POWER  
 200-240V ~ 50/60Hz 25.1A for LIGHT POWER

CE 

NEC Display Solutions Ltd.  
4-28, Mita 1-chome, Minato-ku, Tokyo, Japan  
MADE IN CHINA

Contact address for EMEA  
NEC Display Solutions Europe GmbH  
Landshuter Allee 12-14  
80637 Munich, Germany

Tegangan dan Frekuensi:  
C1: 200-240V ~ 50/60Hz  
C2: 200-240V ~ 50/60Hz (PROYEKTOR CATU DAYA)  
200-240V ~ 50/60Hz (CAHAYA CATU DAYA)  
Produksi China

THIS CABINET IS CONSTRUCTED OF METAL(AL)

	<b>警告</b>	<b>高压注意</b>
	サービスマン以外の方は外装パネルを外さないでください。内部には高電圧部分が多くあり、万一さわると危険です。	

**使用上の注意**  
 イ、通風孔をふさがないでください。内部温度の上昇を招き故障の原因になります。  
 ロ、温度の高い場所や湿気の多い場所での使用はさけてください。

**CAUTION:** TO PREVENT ELECTRIC SHOCK, DO NOT OPEN TOP COVER. NO USER-SERVICEABLE PARTS INSIDE.  
**ATTENTION:** AFIN DE PREVENIR UN CHOC ELECTRIQUE NE PAS ENLEVER LE COUVERCLE S'ADRESSER A UN REPARATEUR COMPETENT.  
**ВНИМАНИЕ:** ВО ИЗБЕЖАНИЕ УДАРА ЭЛЕКТРИЧЕСКИМ ТОКОМ НЕ ОТКРЫВАЙТЕ ВЕРХНЮЮ КРЫШКУ. ВНУТРИ НЕТ ДЕТАЛЕЙ, ОБСЛУЖИВАЕМЫХ ПОЛЬЗОВАТЕЛЕМ.  
**주의:** 전기충격 방지를 위해 캐비닛을 열지 마십시오. 내부에는 사용자를 위한 서비스가능 부품이 들어있지 않습니다.  
**ACHTUNG:** Zur Vermeidung eines elektrischen Schlages, öffnen Sie das Gehäuse nicht selbst. In diesem Gerät sind keine Teile enthalten, die vom Nutzer gewartet werden können.

この装置は、クラスA機器です。この装置を住宅環境で使用すると電波妨害を引き起こすことがあります。この場合には使用者が適切な対策を講ずるよう要求されることがあります。 VCCI-A

THIS DEVICE COMPLIES WITH PART 15 OF THE FCC RULES, OPERATION IS SUBJECT TO THE FOLLOWING TWO CONDITIONS:  
 (1) THIS DEVICE MAY NOT CAUSE HARMFUL INTERFERENCE, AND  
 (2) THIS DEVICE MUST ACCEPT ANY INTERFERENCE RECEIVED, INCLUDING INTERFERENCE THAT MAY CAUSE UNDESIRE OPERATION.  
 CAN ICES-3(A)/NMB-3(A)

Label D



MODEL NO. NP-XXXXXXX XXXXXXXX

Label E

M/F Date : YYYY. MM. DD

**Radiation Range of Emitted Light by the Projector (HD: Hazard Distance)**

- The below table describes the radiation range of emitted light by the projector that is classified as Risk Group 3 (RG3) of IEC62471-5 First edition 2015.
- The below table describes the radiation range of emitted light by the projector that is classified as Risk Group 3 (RG3) of IEC62471:2006 (for USA).
- Please keep within bounds for installing the projector.  
 Install a barrier for preventing human eyes from entering the RG3 area. For the barrier installation position, keep horizontal safety zone over 1.5m from the RG3 area. In case to install the projector over head, keep over 3m distance at least between the floor surface and the RG3 area.  
 Operators shall control access to the beam within the hazard distance or install the product at the height that will prevent exposures of spectators' eyes within the hazard distance.

(IEC62471-5 First edition 2015)

Lens	RG3 HD(m)	Screen size(m)	
		H	V
L2K-10F1	4.1	4.51	2.38
L4K-11ZM	Wide	4.6	2.15
	Tele	7.1	2.18
L4K-15ZM	Wide	6.2	2.25
	Tele	9.1	2.29
L4K-20ZM	Wide	8.2	2.18
	Tele	14.0	2.17
L2K-30ZM	Wide	11.0	2.15
	Tele	16.0	2.16
L2K-43ZM1	Wide	16.0	2.16
	Tele	22.0	2.15
L2K-55ZM1	Wide	21.0	2.21
	Tele	32.0	2.19

(IEC62471:2006 (for USA))

Lens	RG3 HD(m)	Screen size(m)		EHv
		H	V	
L2K-10F1	4.1	4.51	2.38	10
L4K-11ZM	Wide	4.6	2.15	11
	Tele	7.1	2.18	14
L4K-15ZM	Wide	6.2	2.25	12
	Tele	9.1	2.29	17
L4K-20ZM	Wide	8.2	2.18	16
	Tele	14.0	2.17	17
L2K-30ZM	Wide	11.0	2.15	20
	Tele	16.0	2.16	22
L2K-43ZM1	Wide	16.0	2.16	22
	Tele	22.0	2.15	22
L2K-55ZM1	Wide	21.0	2.21	24
	Tele	32.0	2.19	27

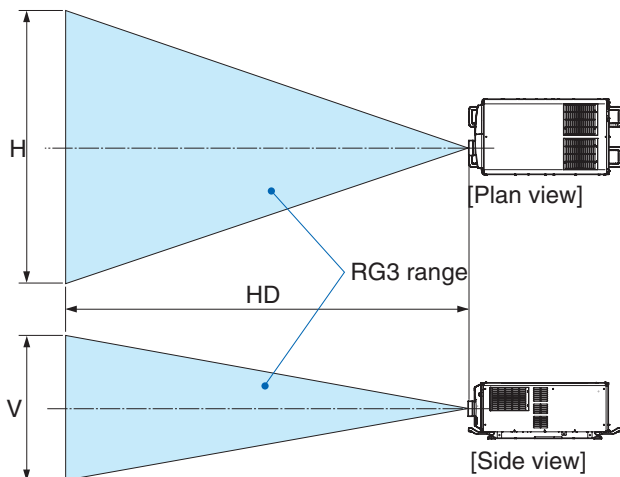

\* If lens shift is utilized, please consider the shift of projected image according to the volume of lens shift. (→ page 10)



### **Please heed all precaution for safety.**

#### **To install the projector**

- For planning the layout of the projector, make sure to take safety measures instructed on the installation manual.
- In order to refuse danger, install either a wall outlet within easy reach for pulling out the power plug in emergency or a device as a breaker to shut down the power supply to the projector.
- Take safety measures preventing human eyes from entering the RG3 area.
- Considering the installation place, select an appropriate lens and secure safety zone that is determined for each lens. For operation on the powered projector as light adjustment, make sure appropriate safety measures have been taken.
- Check the validity of taken security measures if appropriate safety zone based on the installed lens is secured. Periodically check the validity and keep these results.
- Educate the administrator of the projector (operators) about safety before starting to operate the projector.

#### **To use the projector**

- Instruct the administrator of the projector (operators) to perform inspections before powering on the projector. (Including the safety check against emitted light by the projector)
- Instruct the administrator of the projector (operators) to be in circumstances able to control the projector whenever the projector is powered on for an emergency.
- Instruct the administrator of the projector (operators) to keep the installation manual, user's manual and inspection records to a place where they can take these documents out easily.
- Instruct them to clarify if the projector is conformed to standards of each country and region.

### **Health precautions to users viewing 3D images**





Before viewing, be sure to read health care precautions that may be found in the user's manual included with your 3D eyeglasses or your 3D compatible content such as Blu-ray Discs, video games, computer's video files and the like. To avoid any adverse symptoms, heed the following:

- Do not use 3D eyeglasses for viewing any material other than 3D images.
- Allow a distance of 2 m/7 feet or greater between the screen and a user. Viewing 3D images from too close a distance can strain your eyes.
- Avoid viewing 3D images for a prolonged period of time. Take a break of 15 minutes or longer after every hour of viewing.
- If you or any member of your family has a history of light-sensitive seizures, consult a doctor before viewing 3D images.
- While viewing 3D images, if you get sick such as nausea, dizziness, queasiness, headache, eyestrain, blurry vision, convulsions, and numbness, stop viewing them. If symptoms still persist, consult a doctor.
- View 3D images from the front of the screen. Viewing from an angle may cause fatigue or eyestrain.

### **About Copyright of original projected pictures:**

Please note that using this projector for the purpose of commercial gain or the attraction of public attention in a venue such as a coffee shop or hotel and employing compression or expansion of the screen image with the following functions may raise concern about the infringement of copyrights which are protected by copyright law. [ASPECT RATIO], Magnifying feature and other similar features.

# Wichtige Informationen

	Dieses Symbol warnt den Benutzer vor nicht isolierter Spannung im Innern des Geräts, die hoch genug sein kann, um einen Stromschlag zu verursachen. Deshalb ist es gefährlich, einen Teil im Innern dieses Geräts auf irgendeine Weise zu berühren.
	Dieses Symbol weist den Benutzer darauf hin, dass wichtige Informationen hinsichtlich des Betriebs und der Wartung dieses Geräts enthalten sind. Diese sind deshalb sorgfältig zu lesen, um jegliche Probleme zu vermeiden.
	Dieses Symbol weist auf etwas hin, das verboten ist.
	Dieses Symbol weist auf etwas hin, das nicht zerlegt werden darf.
	Dieses Symbol weist auf etwas hin, auf das geachtet werden muss.



- Schauen Sie nicht in die Linse, wenn der Projektor eingeschaltet ist. Dies könnte schwere Augenverletzungen zur Folge haben.



- Lichtkegel des Projektors fern. Da das von der Linse projizierte Licht umfassend ist, können alle abnormalen Gegenstände, die in der Lage sind, das aus der Linse austretende Licht umzulenken, unvorhersehbare Ereignisse wie z.B. einen Brand oder Augenverletzungen verursachen.
- Wenn Sie den Projektor einschalten, stellen Sie sicher, dass sich keine Personen in dem vom Laser abgegebenen Lichtstrahl zur Linse hingewandt befinden.

## Maschinenlärminformations-Verordnung – 3. GPSGV,

Der höchste Schalldruckpegel beträgt 70 dB(A) oder weniger gemäß EN ISO 7779.

### **WARNUNG**

Dieses Gerät entspricht Klasse A von CISPR 32. Dieses Produkt kann Funkstörungen in der häuslichen Umgebung verursachen.

### **ACHTUNG**

ZUR VERMEIDUNG EINES ELEKTRISCHEN SCHLAGS ÖFFNEN SIE NICHT DIE OBERE ABDECKUNG. IM INNEREN GIBT ES KEINE ZU WARTENDEN TEILE.



### **Vorsichtsmaßnahmen zur Lasersicherheit**

Dieses Produkt ist gemäß IEC60825-1 Dritte Auflage 2014 als Klasse 1 klassifiziert. Dieses Produkt ist als RG3 von IEC62471-5 Erste Ausgabe 2015 eingestuft. Beachten Sie bei der Installation und Verwaltung des Geräts die Gesetze und Bestimmungen Ihres Landes.

### **ACHTUNG**

Die Verwendung von Bedienelementen oder die Änderung von Prozeduren in Abweichung von den in diesem Handbuch beschriebenen könnte zu gefährlichem Kontakt mit Laserstrahlung führen.

- Keine direkte Exposition gegenüber dem Strahl ist zulässig, RG3 IEC 62471-5: 2015.

### **ACHTUNG**

Verwenden Sie ein Signalkabel mit Ferritkern, um Störungen beim Radio- und Fernsehempfang zu reduzieren. Die Verwendung eines Signalkabels ohne Ferritkern kann Störungen beim Radio- und Fernsehempfang verursachen.

Durch Prüfung dieses Gerätes nach FCC, Part 15 wurde die Einhaltung der Grenzwerte für digitale „Class A“-Geräte bestätigt. Diese Grenzwerte gelten für einen wirksamen Schutz gegen Störungen in Gewerbegebieten. Dieses Gerät erzeugt und verwendet Funkfrequenzenergie und kann diese ausstrahlen und kann, wenn es nicht entsprechend dem Bedienungshandbuch aufgestellt und betrieben wird, Störungen beim Radio- und Fernsehempfang verursachen. Die Verwendung dieses Gerätes in Wohngebieten verursacht wahrscheinlich Störungen, die der Benutzer in eigener Verantwortung zu beseitigen hat.

### **WARNUNG**



#### **Nicht auseinanderbauen**

DER ENDBENUTZER DARF DAS PRODUKT NICHT ÖFFNEN ODER MODIFIZIEREN.  
ES GIBT KEINE VOM BENUTZER ZU WARTENDEN TEILE.

DIE WARTUNG DES PRODUKTS DARF NUR VON NEC-AUTORISIERTEN TECHNIKERN DURCHFÜHRT WERDEN.

## Wichtige Sicherheitshinweise

Diese Sicherheitshinweise sollen eine lange Lebensdauer Ihres Projektors sicherstellen und vor Feuer und elektrischen Schlägen schützen. Lesen Sie diese Hinweise sorgfältig durch und beachten Sie alle Warnungen.

### Installation

1. Richten Sie den Projektionsstrahl nicht auf Personen oder reflektierende Gegenstände.
2. Wenn Sie Informationen zum Transport und zur Installation des Projektors wünschen, wenden Sie sich an Ihren Händler. Versuchen Sie nicht, den Projektor selbst zu transportieren oder zu installieren. Zur Gewährleistung eines ordnungsgemäßen Betriebs des Projektors und zur Minimierung des Risikos von Verletzungen von Personen muss der Projektor von qualifizierten Technikern installiert werden.
3. Stellen Sie den Projektor auf eine flache, waagerechte Fläche in einer trockenen Umgebung; frei von Staub und Feuchtigkeit. Drehen Sie den Projektor nicht auf die Seite, wenn der Laser eingeschaltet ist. Andernfalls kann es zur Beschädigung des Projektors kommen.

4. Stellen Sie den Projektor weder in direktes Sonnenlicht noch in die Nähe einer Heizung oder sonstiger Hitze abstrahlender Einrichtungen.
5. Wenn das Gerät direktem Sonnenlicht, Rauch oder Dampf ausgesetzt wird, können interne Komponenten beschädigt werden.
6. Behandeln Sie Ihren Projektor vorsichtig. Fallenlassen oder starkes Schütteln kann interne Komponenten beschädigen.
7. Zum Tragen des Projektors werden mindestens sechs Personen benötigt. Bewegen Sie den Projektor stets, indem Sie ihn sicher an den vorderen und hinteren Griffen halten.
8. Halten Sie den Projektor nicht mit der Hand am Linsenbereich fest. Andernfalls kann der Projektor umkippen oder herunterfallen und Verletzungen verursachen.
9. Legen Sie keine schweren Gegenstände auf den Projektor.
10. Schalten Sie den Projektor aus, und ziehen Sie das Netzkabel ab, bevor Sie den Projektor umsetzen. Für Anschluss C2 schalten Sie den Projektor aus, und trennen Sie die Netzspannung zur Spannungsversorgung des Projektors und der Lichtquelle mithilfe eines Ausschalters. Trennen Sie die Kabel zwischen Geräten und der Lampe, bevor Sie den Projektor bewegen.
11. Installieren und bewahren Sie den Projektor nicht unter den nachfolgend aufgeführten Umständen auf. Nichtbeachtung kann eine Fehlfunktion verursachen.
  - In starken Magnetfeldern
  - In einer Umgebung mit Schadgas
  - Im Freien
12. Wenn Sie spezielle Installationsarbeiten benötigen, wie zum Beispiel die Befestigung an der Decke oder das Aufhängen an der Decke mittels Ringschrauben:
  - Versuchen Sie nicht, den Projektor selbst zu installieren.
  - Der Projektor muss von qualifiziertem Servicepersonal installiert werden, um einen ordnungsgemäßen Betrieb sicherzustellen und die Verletzungsgefahr zu reduzieren.
  - Die Decke muss für das Gewicht des Projektors eine ausreichende Festigkeit aufweisen und die Installation muss entsprechend den örtlichen Bauvorschriften ausgeführt werden.
  - Wenn Sie den Projektor an einer hohen Stelle wie zum Beispiel von einer Decke aufhängen, verwenden Sie (handelsübliche) Fallschutzkabel, um die Objektivereinheit zu sichern. Andernfalls kann sich die Objektivereinheit lösen und herunterfallen.
  - Stellen Sie sicher, dass der Projektor auf einer ausreichend haltbaren Oberfläche befestigt ist, um das gesamte Projektorgewicht (das Projektorgewicht einschließlich LV-Einheit 170 kg plus das Objektivgewicht 9 kg, d. H. Insgesamt 179 kg) lange zu halten.
  - Weitere Informationen erhalten Sie von Ihrem Fachhändler.

### WARNUNG



#### Nicht tun

1. Verwenden Sie den Projektor nicht, während die mitgelieferte Linsenkappe oder Ähnliches angebracht ist, und der Projektor in Betrieb ist. Andernfalls kann sich die Linsenkappe oder Glasschutzkappe erhitzen und sich verformen oder schmelzen.
2. Platzieren Sie keine hitzeempfindlichen Objekte vor der Projektorlinse. Dies könnte zum Schmelzen des Objekts durch die Hitze am Lichtausgang führen.



Dieses Gerät kann in vertikaler Position 360° gedreht angebracht werden.

Verwenden Sie den Projektor nicht, wenn er nach links oder rechts geneigt ist. Dies kann zu einer Fehlfunktion führen, die Installation im Hochformat ist jedoch möglich. Bitte lesen Sie die Warnhinweise für die Installation im Hochformat, bevor Sie den Projektor im Hochformat installieren.

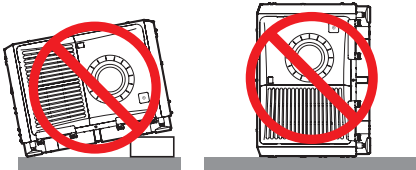

### Spannungsversorgung

1. Zum Installieren des Netzkabels am Projektor wenden Sie sich bitte an Ihren Fachhändler. **UNTER KEINEN UMSTÄNDEN** versuchen, das Netzkabel selbst zu installieren. Brand- und Schlaggefahr. Der Projektor wurde so konzipiert, dass er mit der unten aufgeführten Netzspannung läuft.  
Für Anschluss C1  
(Wenn die Netzspannung zur Spannungsversorgung des Projektors und der Lichtquelle über ein einzelnes Kabel zugeführt wird)
  - AC 200 V-240 V einphasig 50/60 HzFür Anschluss C2  
(Wenn die Netzspannung zur Spannungsversorgung des Projektors und der Lichtquelle über getrennte Kabel zugeführt wird)
  - AC 200 V-240 V einphasig 50/60 Hz (Spannungsversorgung zum Projektor)
  - AC 200 V-240 V einphasig 50/60 Hz (Spannungsversorgung zur Lichtquelle)Stellen Sie sicher, dass die vorhandene Spannungsversorgung diesen Vorgaben entspricht, bevor Sie versuchen, Ihren Projektor zu betreiben.

2. Es wird kein Netzkabel mit dem Projektor geliefert. Fragen Sie Ihren Händler, welches Netzkabel auszuwählen und zu kaufen ist. Verwenden Sie ein Netzkabel, das die Normen und Netzspannung des Landes, in dem der Projektor verwendet wird, erfüllt. Siehe „1-9. Anschließen des Netzkabels“ (→ Seite 38) für Einzelheiten zum Anschließen des Netzkabels.
3. Behandeln Sie das Netzkabel vorsichtig. Ein beschädigtes oder durchgescheuertes Netzkabel kann elektrische Schläge oder einen Brand verursachen.
  - Biegen oder ziehen Sie das Netzkabel nicht übermäßig.
  - Legen Sie das Netzkabel nicht unter den Projektor oder unter einen anderen schweren Gegenstand.
  - Bedecken Sie das Netzkabel auch nicht mit weichen Materialien, z. B. mit Teppichen.
  - Erhitzen Sie das Netzkabel nicht.
4. Wenn Sie das Netzkabel und das Signalkabel in unmittelbarer Nähe zueinander platzieren, kann Überlagerungsrauschen auftreten. Vergrößern Sie in einem derartigen Fall den Abstand zwischen diesen beiden Kabeln.  
Bildrauschen ist ein Bildfehler, der oft als rollendes Band durch das Bild sichtbar wird.
5. Berühren Sie den Projektor auf keinen Fall während eines Gewitters. Wenn Sie dies nicht beachten, kann dies zu einem elektrischen Schlag oder einem Feuer führen.
6. Wenn der Projektor an der Decke montiert wird, installieren Sie den Leistungsschalter an einer Stelle, die von Hand leicht erreichbar ist.

### VORSICHT

Diese Ausrüstung ist für den Gebrauch mit einem geerdeten Netzkabel entworfen. Wenn das Netzkabel nicht geerdet ist, kann dies zu einem elektrischen Schlag führen. Bitte achten Sie darauf, dass das Netzkabel ordnungsgemäß geerdet ist.



### Vorsichtsmaßnahmen zur Vermeidung von Bränden und elektrischen Schlägen

1. Sorgen Sie für ausreichende Belüftung und stellen Sie außerdem sicher, dass die Lüftungsschlitze frei bleiben, damit sich innerhalb des Projektors kein Hitzestau bilden kann. Lassen Sie mindestens 60 cm Abstand zwischen Ihrem Projektor und der Wand. Halten Sie insbesondere einen Freiraum von mindestens 70 cm vor dem Luftauslass auf der Rückseite und von mindestens 30 cm oberhalb des Projektorgehäuses. (→ Seite 3)
2. Vermeiden Sie, dass Fremdgegenstände wie Büroklammern und Papierschnipsel in den Projektor fallen. Versuchen Sie nicht, in den Projektor gefallene Gegenstände selbst zu entfernen. Stecken Sie keine Metallgegenstände wie einen Draht oder Schraubendreher in Ihren Projektor. Wenn etwas in den Projektor gefallen ist, schalten Sie sofort die Stromversorgung des Projektors ab, und lassen Sie den Gegenstand von qualifiziertem Servicepersonal entfernen. Für Anschluss C2 schalten Sie den Projektor aus, trennen Sie die Netzspannung zur Spannungsversorgung des Projektors und der Lichtquelle mithilfe eines Ausschalters und wenden Sie sich an Ihren Händler/Lieferanten.
3. Schalten Sie den Projektor aus, ziehen Sie den Netzstecker und kontaktieren Sie unter den folgenden Bedingungen qualifiziertes Service-Personal. Für Anschluss C2 schalten Sie den Projektor aus, trennen Sie die Netzspannung zur Spannungsversorgung des Projektors und der Lichtquelle mithilfe eines Ausschalters und wenden Sie sich für Reparaturarbeiten an Ihren Händler/Lieferanten.
  - Wenn das Netzkabel oder der Netzstecker beschädigt oder ausgefranst ist.
  - Falls Flüssigkeit in den Projektor gelangt ist, oder wenn er Regen oder Wasser ausgesetzt war.
  - Falls der Projektor nicht normal arbeitet, obwohl Sie die in diesem Bedienungshandbuch beschriebenen Anleitungen befolgen.
  - Wenn der Projektor fallengelassen oder das Gehäuse beschädigt wurde.
  - Wenn der Projektor eine eindeutige Leistungsänderung aufweist, die einer Wartung bedarf.
4. Wenn ein LAN-Kabel verwendet wird: Schließen Sie es aus Sicherheitsgründen nicht an den Anschluss der Peripheriegeräte-Verbindung an, das sie eine zu hohe Spannung führen könnte.
5. Bringen Sie stets den Netzkabelverschluss an, bevor Sie versuchen, Ihren Projektor zu benutzen. Siehe Seite 50 Wissenswertes über den Netzkabelverschluss.

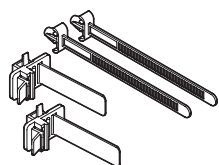

### Reinigung

1. Schalten Sie vor der Reinigung die Stromversorgung durch Herausdrehen der Sicherung ab. Für Anschluss C2 schalten Sie den Projektor aus und trennen Sie die Netzspannung zur Spannungsversorgung des Projektors und der Lichtquelle mithilfe eines Ausschalters.
2. Reinigen Sie das Gehäuse regelmäßig mit einem Tuch. Bei starker Verschmutzung verwenden Sie ein mildes Reinigungsmittel. Reinigen Sie das Gerät niemals mit starken Reinigungs- oder Lösungsmitteln wiez.B. Alkohol oder Verdünner.
3. Reinigen Sie die Linse mit einer Blaseinrichtung oder einem Linsentuch. Beachten Sie dabei, dass die Linsenoberfläche weder zerkratzt noch auf andere Weise beschädigt wird.
4. Berühren Sie den Projektor oder das Netzkabel nicht mit nassen Händen. Andernfalls kann es zu elektrischen Schlägen oder zu einem Brand kommen.
5. Verwenden Sie kein Sprühmittel, das ein brennbares Gas enthält, um den am Objektiv und Gehäuse anhaftenden Staub zu entfernen. Dadurch können Brände entstehen.

#### ACHTUNG

#### Nicht tun

1. In den folgenden Situationen darf die Netzspannung nicht getrennt werden. Der Projektor könnte sonst beschädigt werden.
  - Während der Projizierung von Bildern
  - Während des Abkühlens nach Ausschalten der Stromzufuhr.
2. Schalten Sie den Wechselstrom 90 Sekunden lang nicht aus, nachdem der Laser eingeschaltet wurde und während die POWER-Anzeige grün blinkt. Andernfalls könnte der Laser vorzeitig ausfallen.
3. Halten Sie die Hände fern vom Linsenmontageteil, während der Linsenversatz in Betrieb ist. Andernfalls könnten Finger zwischen Gehäuse und Linsendeckel eingeklemmt werden.
4. Wenn das Hauptteil beschädigt ist, kann Kühlungsflüssigkeit aus dem Inneren austreten. Berühren Sie die Flüssigkeit NICHT, und trinken Sie sie NICHT. Wenn die Kühlungsflüssigkeit geschluckt wurde oder in Augenkontakt kam, rufen Sie bitte sofort einen Arzt.

### Vorsicht beim Transportieren des Projektors/Umgang mit der optischen Linse

Wenn Sie ein Objektiv installieren / entfernen, schalten Sie die Stromversorgung des Projektors ab.  
Wenn Sie den Projektor mit der Linse verschicken, entfernen Sie die Linse vor dem Versand. Bringen Sie immer die Staubschutzkappe an der Linse an, wenn diese nicht am Projektor angebracht ist. Die Linse und der Lens Shift Mechanismus können durch unsachgemäße Handhabung während des Transports beschädigt werden.

### Kabelinformationen

#### VORSICHT

Für HDMI, DisplayPort, BNC, LAN, RS232C, 3D und GP I/O verwenden Sie bitte ein abgeschirmtes Kabel. Das Verwenden anderer Kabel kann Störungen beim Fernseh- und Rundfunkempfang verursachen.

### Vorsichtsmaßnahmen zur Fernbedienung

- Behandeln Sie die Fernbedienung mit Sorgfalt.
- Wischen Sie die Fernbedienung sofort trocken, wenn sie einmal nass geworden sein sollte.
- Vermeiden Sie übermäßige Hitze und Feuchtigkeit.
- Schließen Sie die Batterien nicht kurz, erhitzen Sie sie nicht und nehmen Sie sie nicht auseinander.
- Nehmen Sie die Batterien heraus, wenn Sie beabsichtigen, die Fernbedienung über einen längeren Zeitraum hinweg nicht zu benutzen.
- Stellen Sie sicher, dass die Batteriepole (+/-) richtig ausgerichtet sind.
- Verwenden Sie niemals verschiedene Batterietypen oder neue und alte Batterien zusammen.

### Umgang mit der Batterie

- Seien Sie ausserst vorsichtig beim Hantieren der Batterie, um jedes Risiko von Brand, Verletzungen oder Beschädigungen anderer Objekte.
  - Die Batterien nicht kurzschliessen, demontieren oder ins Feuer werfen.
- Entsorgen Sie verbrauchte Batterien entsprechend den in Ihrem Land geltenden Bestimmungen.
- Auf der Leiterplatte der Haupteinheit ist eine Batterie montiert.  
Zerlegen Sie die Haupteinheit beim Entsorgen nicht, und entfernen Sie nicht die interne Leiterplatte. Wenden Sie sich stattdessen an den Händler, bei dem Sie das Gerät erworben haben, oder an die zuständige Behörde.

### Lichtmodul

1. Als Lichtquelle dient dem Produkt ein Lichtmodul bestehend aus mehreren Laserdioden.
2. Diese Laserdioden sind im Lichtmodul eingeschlossen. Für die Leistung des Lichtmoduls ist keine Wartung erforderlich.
3. Der Endbenutzer darf das Lichtmodul nicht austauschen.
4. Wenden Sie sich an einen qualifizierten Händler, wenn Sie das Lichtmodul austauschen wollen oder weitere Informationen benötigen.

### Entsorgung Ihres benutzten Gerätes



Die EU-weite Gesetzgebung, wie sie in jedem einzelnen Mitgliedstaat gilt, bestimmt, dass benutzte elektrische und elektronische Geräte mit dieser Markierung (links) getrennt vom normalen Haushaltsabfall entsorgt werden müssen.

Dies schließt Projektoren und deren elektrisches Zubehör mit ein. Folgen Sie beim Entsorgen eines solchen Gerätes bitte den Anweisungen Ihrer örtlichen Behörde und/oder konsultieren Sie den Händler, bei dem Sie das Gerät erworben haben.

Nach der Sammlung benutzter Geräte werden diese erneut verwendet und entsprechend den Umweltbestimmungen recycelt. Das trägt dazu bei, die Abfallmenge sowie die negativen Auswirkungen auf die menschliche Gesundheit und die Umwelt auf ein Minimum zu reduzieren.

Die Markierung auf elektrischen und elektronischen Geräten gilt nur für die gegenwärtigen Mitgliedstaaten der Europäischen Union.



**Für die EU:** Der durchgestrichene Abfallbehälter bedeutet, dass verbrauchte Batterien nicht über den allgemeinen Hausmüll entsorgt werden dürfen. Es gibt ein getrenntes Sammelsystem für Altbatterien, um die ordnungsgemäße Behandlung und Wiederverwertung entsprechend den geltenden Vorschriften zu ermöglichen.

**Gemäß der Richtlinie 2006/66/EG dürfen Batterien nicht auf ungeeignete Weise entsorgt werden. Die Batterie muss getrennt durch einen örtlichen Entsorger gesammelt werden.**

Etiketteninformationen

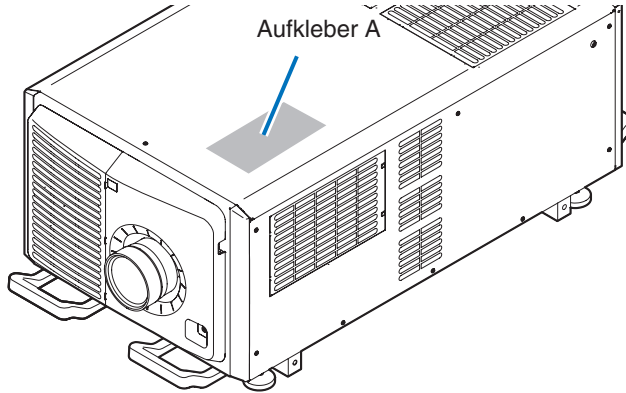

Aufkleber A: Lampe Warnzeichen Etikette



**RISK GROUP 3  
WARNING**  
DO NOT LOOK INTO THE BEAM.  
NO DIRECT EYE EXPOSURE TO THE BEAM IS PERMITTED.  
HAZARD DISTANCE: REFER TO THE MANUAL.

**GROUPE DE RISQUE 3  
AVERTISSEMENT**  
NE PAS REGARDER DIRECTEMENT DANS LE FAISCEAU.  
L'EXPOSITION DIRECTE DES YEUX AU FAISCEAU EST INTERDITE.  
DISTANCE À RISQUE: SE REPORTER AU MANUEL.

**RISIKOGRUPPE 3  
WARNUNG**  
SCHAUEN SIE NICHT IN DEN STRAHL.  
DIREKTER AUGENKONTAKT MIT DEM STRAHL IST NICHT ERLAUBT.  
SICHERHEITSABSTAND: SIEHE HANDBUCH.

**ГРУППА РИСКА 3  
ПРЕДУПРЕЖДЕНИЕ**  
НЕ СМОТРИТЕ НА ЛУЧ.  
ЗАПРЕЩАЕТСЯ ЛЮБОЕ ПРЯМОЕ ВОЗДЕЙСТВИЕ ЛУЧА НА ГЛАЗА.  
ОПАСНОЕ РАСТОЯНИЕ: СМ. РУКОВОДСТВО ПО ЭКСПЛУАТАЦИИ.

**リスクグループ 3  
警告**  
ビームを見ないこと。  
目へのビームの直接照射を禁止する。  
障害距離: 取扱説明書を参照。

**위험 그룹 3  
경고**  
빔을 눈으로 보지 마십시오.  
빔을 직접 눈에 노출하는 것은 허용되지 않습니다.  
위험 거리: 설명서를 참조하십시오.

**风险组别 3  
警告**  
请勿直视光束。  
不允许将眼睛暴露于光束中。  
有害距离: 请参阅手册。  
IEC/EN 62471-5:2015

  

**FOR NORTH AMERICA  
RISK GROUP 3  
WARNING**  
HAZARDOUS OPTICAL RADIATION EMITTED FROM THIS PRODUCT.  
DO NOT LOOK AT OPERATING LIGHT SOURCE.  
EYE INJURY MAY RESULT.  
HAZARD DISTANCE: REFER TO THE MANUAL.  
NO DIRECT EXPOSURE TO BEAM SHALL BE PERMITTED.  
NOT FOR HOUSEHOLD USE.

**GROUPE DE RISQUE 3  
AVERTISSEMENT**  
RADIATIONS OPTIQUES DANGEREUSES EMISES PAR CE PRODUIT.  
NE REGARDER PAS DIRECTEMENT LA SOURCE LUMINEUSE.  
CELA POURRAIT ENTRAÎNER DES BLESSURES AUX YEUX.  
DISTANCE À RISQUE: SE REPORTER AU MANUEL.  
L'EXPOSITION DIRECTE AU RAYON DOIT ÊTRE AUTORISÉE.  
NE CONVIENT PAS À UN USAGE DOMESTIQUE.

IEC/TR 62471-2:2009  
IEC/EN 62471:2006

Aufkleber B  
Laser erklärendes Etikett

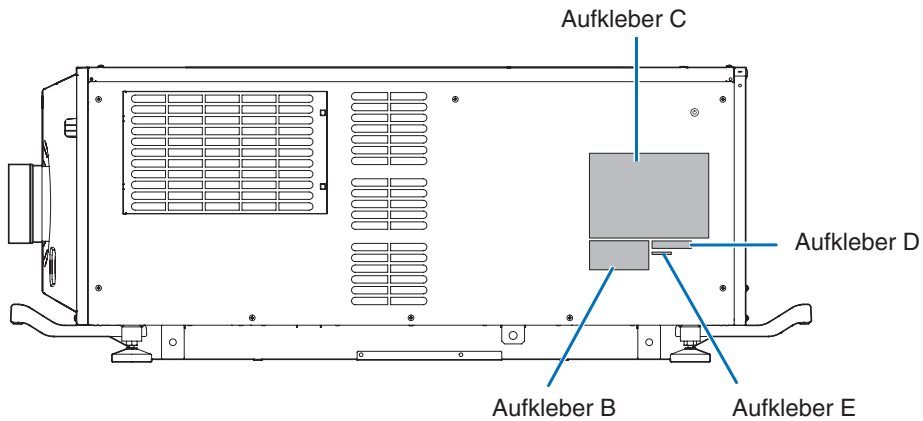

Aufkleber C  
PH3501QL

**NEC** MODEL No. NP-PH3501QL C1: 200-240V ~ 50/60Hz 30.0A  
 C2: 200-240V ~ 50/60Hz 4.9A for PJ POWER  
 200-240V ~ 50/60Hz 25.1A for LIGHT POWER

CE

NEC Display Solutions, Ltd. 4-28, Mita 1-chome, Minato-ku, Tokyo, Japan  
 Contact address for EMEA NEC Display Solutions Europe GmbH Landshuter Allee 12-14 80637 Munich, Germany  
 Tegangan dan Frekuensi: C1: 200-240V ~ 50/60Hz C2: 200-240V ~ 50/60Hz (PROYEKTOR CATU DAYA) 200-240V ~ 50/60Hz (CAHAYA CATU DAYA) Produksi China

MADE IN CHINA THIS CABINET IS CONSTRUCTED OF METAL(AL)

	<b>警告</b> 高圧注意
	サービスマン以外の方は外装パネルを外さないでください。内部には高電圧部分が数多くあり、カーさわると危険です。
<b>使用上の注意</b> イ. 通風孔をふさがないでください。内部温度の上昇を招き故障の原因になります。 ロ. 温度の高い場所や湿気の多い場所での使用はさけてください。	

**CAUTION:** TO PREVENT ELECTRIC SHOCK, DO NOT OPEN TOP COVER. NO USER-SERVICEABLE PARTS INSIDE.  
**ATTENTION:** AFIN DE PREVENIR UN CHOC ELECTRIQUE NE PAS ENLEVER LE COUVERCLE S'ADRESSER A UN REPARATEUR COMPETENT.  
**ВНИМАНИЕ:** ВО ИЗБЕЖАНИЕ УДАРА ЭЛЕКТРИЧЕСКИМ ТОКОМ НЕ ОТКРЫВАЙТЕ ВЕРХНЮЮ КРЫШКУ. ВНУТРИ НЕТ ДЕТАЛЕЙ, ОБСЛУЖИВАЕМЫХ ПОЛЬЗОВАТЕЛЕМ.  
**주의:** 전기충격 방지를 위해 캐비닛을 열지 마십시오. 내부에는 사용자를 위한 서비스가능 부품이 들어있지 않습니다.  
**ACHTUNG:** Zur Vermeidung eines elektrischen Schlages, öffnen Sie das Gehäuse nicht selbst. In diesem Gerät sind keine Teile enthalten, die vom Nutzer gewartet werden können.

この装置は、クラス A 機器です。この装置を住宅環境で使用すると電波妨害を引き起こすことがあります。この場合には使用者が適切な対策を講ずるよう要求されることがあります。 VCCI-A

THIS DEVICE COMPLIES WITH PART 15 OF THE FCC RULES, OPERATION IS SUBJECT TO THE FOLLOWING TWO CONDITIONS:  
 (1) THIS DEVICE MAY NOT CAUSE HARMFUL INTERFERENCE, AND  
 (2) THIS DEVICE MUST ACCEPT ANY INTERFERENCE RECEIVED, INCLUDING INTERFERENCE THAT MAY CAUSE UNDESIRE OPERATION. CAN ICES-3(A)/NMB-3(A)

Aufkleber C  
PH2601QL

**NEC** MODEL No. NP-PH2601QL C1: 200-240V ~ 50/60Hz 30.0A  
C2: 200-240V ~ 50/60Hz 4.9A for PJ POWER  
200-240V ~ 50/60Hz 25.1A for LIGHT POWER

CE 

NEC Display Solutions Ltd. 4-28, Mita 1-chome, Minato-ku, Tokyo, Japan  
Contact address for EMEA NEC Display Solutions Europe GmbH Landshuter Allee 12-14 80637 Munich, Germany  
Tagangan dan Frekuensi: C1: 200-240V ~ 50/60Hz C2: 200-240V ~ 50/60Hz (PROYEKTOR CATU DAYA) 200-240V ~ 50/60Hz (CAHAYA CATU DAYA) Produksi China

MADE IN CHINA  
THIS CABINET IS CONSTRUCTED OF METAL(AL)

	<b>警告 高压注意</b> サービスマン以外の方は外装パネルを外さないでください。内部には高電圧部分が多くあり、万一さわると危険です。
---	---

**使用上の注意**  
イ、通風孔をふさがないでください。内部温度の上昇を招き故障の原因になります。ロ、温度の高い場所や湿気の多い場所での使用はさけてください。

**CAUTION:** TO PREVENT ELECTRIC SHOCK, DO NOT OPEN TOP COVER. NO USER-SERVICEABLE PARTS INSIDE.  
**ATTENTION:** AFIN DE PREVENIR UN CHOC ELECTRIQUE NE PAS ENLEVER LE COUVERCLE S'ADRESSER A UN REPARATEUR COMPETENT.  
**ВНИМАНИЕ:** ВО ИЗБЕЖАНИЕ УДАРА ЭЛЕКТРИЧЕСКИМ ТОКОМ НЕ ОТКРЫВАЙТЕ ВЕРХНЮЮ КРЫШКУ. ВНУТРИ НЕТ ДЕТАЛЕЙ, ОБСЛУЖИВАЕМЫХ ПОЛЬЗОВАТЕЛЕМ.  
**주의:** 전기충격 방지를 위해 캐비닛을 열지 마십시오. 내부에는 사용자를 위한 서비스가능 부품이 들어있지 않습니다.  
**ACHTUNG:** Zur Vermeidung eines elektrischen Schlages, öffnen Sie das Gehäuse nicht selbst. In diesem Gerät sind keine Teile enthalten, die vom Nutzer gewartet werden können.

この装置は、クラスA機器です。この装置を住宅環境で使用すると電波妨害を引き起こすことがあります。この場合には使用者が適切な対策を講ずるよう要求されることがあります。 VCCI-A

THIS DEVICE COMPLIES WITH PART 15 OF THE FCC RULES, OPERATION IS SUBJECT TO THE FOLLOWING TWO CONDITIONS:  
(1) THIS DEVICE MAY NOT CAUSE HARMFUL INTERFERENCE, AND  
(2) THIS DEVICE MUST ACCEPT ANY INTERFERENCE RECEIVED, INCLUDING INTERFERENCE THAT MAY CAUSE UNDESIRE OPERATION. CAN ICES-3(A)/NMB-3(A)

Aufkleber D



Aufkleber E

M/F Date : YYYY. MM. DD

**Strahlungsbereich des abgegebenen Lichts durch den Projektor(Sicherheitsabstand – HD: Hazard distance)**

- Die nachfolgend abgebildete Tabelle gibt den Strahlungsbereich des abgegebenen Lichts durch den Projektor an, das als Risikogruppe 3 (RG3) nach IEC62471-5 Erste Ausgabe 2015 eingestuft.
- Bitte bei der Installation des Projektors die Einschränkungen beachten.  
 Installieren Sie zum Schutz der menschlichen Augen vor dem RG3-Bereich eine Abdeckung. Achten Sie darauf, dass sich bei der Installation der Abdeckung die horizontale Sicherheitszone mindestens 1,5 m vom RG3-Bereich entfernt befindet. Falls der Projektor über Kopf installiert wird, halten Sie einen Abstand von mindestens 3 m zwischen der Bodenfläche und dem RG3-Bereich ein.  
 Bediener müssen den Zugang zum Strahl innerhalb des Gefahrenabstands kontrollieren oder das Produkt so hoch installieren, dass die Augen der Zuschauer innerhalb des Gefahrenabstands nicht dem Strahl ausgesetzt werden können.

Linse	RG3 HD (m)	Bildschirmgröße (m)	
		H	V
L2K-10F1	4,1	4,51	2,38
L4K-11ZM	Breit	4,6	4,07
	Tele	7,1	4,13
L4K-15ZM	Breit	6,2	4,28
	Tele	9,1	4,33
L4K-20ZM	Breit	8,2	4,14
	Tele	14,0	4,12
L2K-30ZM	Breit	11,0	4,07
	Tele	16,0	4,10
L2K-43ZM1	Breit	16,0	4,10
	Tele	22,0	4,07
L2K-55ZM1	Breit	21,0	4,20
	Tele	32,0	4,19

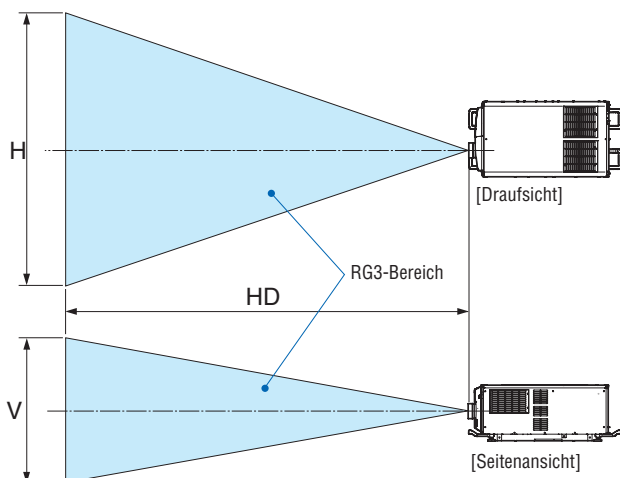

\* Falls der Linsenversatz verwendet wird, berücksichtigen Sie bitte die Verschiebung des projizierten Bildes je nach Umfang des Linsenversatzes. (→ Seite 10)



**Bitte beachten Sie alle Sicherheitshinweise.**

### **Installation des Projektors**

- Beachten Sie bei der Planung des Aufbaus des Projektors die Sicherheitsmaßnahmen im Installationshandbuch.
- Installieren Sie zur Gefahrenverringerung eine Wandsteckdose in Reichweite, damit der Netzstecker im Notfall herausgezogen werden kann, oder einen Trennschalter, um die Stromversorgung zum Projektor unterbrechen zu können.
- Beachten Sie zum Schutz der menschlichen Augen vor dem RG3-Bereich die Sicherheitsmaßnahmen.
- Wählen Sie eine geeignete Linse für den Installationsort aus, und halten Sie die Sicherheitszone, die für die jeweilige Linse vorgesehen ist, ein. Beachten Sie die entsprechenden Sicherheitsmaßnahmen, wenn Sie Einstellungen am Licht des eingeschalteten Projektors vornehmen.
- Prüfen Sie, ob die Sicherheitsmaßnahmen eingehalten wurden, wenn die entsprechende Sicherheitszone gemäß der installierten Linse eingestellt wird. Prüfen Sie dies in regelmäßigen Abständen und dokumentieren Sie die Ergebnisse.
- Weisen Sie den Administrator des Projektors (Bediener) in die Sicherheitsbestimmungen ein, bevor dieser mit dem Betrieb des Projektors beginnt.

### **Verwendung des Projektors**

- Weisen Sie den Administrator des Projektors (Bediener) an, den Projektor vor dem Einschalten zu überprüfen (einschließlich der Sicherheitsprüfung des abgegebenen Lichts durch den Projektor).
- Unterrichten Sie den Administrator des Projektors (Bediener) über die erforderlichen Maßnahmen zur Kontrolle des eingeschalteten Projektors, falls ein Notfall eintritt.
- Weisen Sie den Administrator des Projektors (Bediener) an, das Installationshandbuch, das Benutzerhandbuch und die Inspektionsdokumente an einem Ort zu verwahren, an dem leicht auf diese Dokumente zugegriffen werden kann.
- Weisen Sie ihn an, zu prüfen, ob der Projektor den Standards des entsprechenden Landes und der jeweiligen Region entspricht.

### **Vorsichtsmaßnahmen zur Gesundheit bei der Betrachtung von 3D-Bildern**

Bevor Sie 3D-Bilder betrachten, lesen Sie unbedingt die Vorsichtsmaßnahmen zu Gesundheitsrisiken, die Sie im Benutzerhandbuch Ihrer 3D-Brillen oder Ihrer 3D-kompatiblen Medien wie Blu-ray-Disks, Videospiele, Computervideodateien und dergleichen finden.

Zur Vermeidung von gesundheitsbeeinträchtigenden Symptomen beachten Sie Folgendes:

- Verwenden Sie keine 3D-Brillen zum Betrachten von anderen Materialien als 3D-Bildern.
- Lassen Sie einen Abstand von 2 m/7 Fuß oder mehr zwischen dem Bildschirm und Benutzer. Das Ansehen von 3D-Bildern aus zu naher Entfernung kann Ihre Augen belasten.
- Vermeiden Sie das Betrachten von 3D-Bildern über einen längeren Zeitraum hinweg. Machen Sie nach jeder Stunde eine Pause von 15 Minuten.
- Falls Sie oder ein Mitglied Ihrer Familie schon durch Licht ausgelöste Krampfanfälle hatten, fragen Sie einen Arzt, bevor Sie 3D-Bilder betrachten.
- Wenn während des Betrachtens von 3D-Bildern Symptome wie Übelkeit, Schwindel, Brechreiz, Kopfschmerzen, Augenschmerzen, verschwommene Sicht, Krämpfe oder Taubheitsgefühl auftreten, brechen Sie das Betrachten ab. Wenn die Symptome anhalten, suchen Sie einen Arzt auf.
- Betrachten Sie 3D-Bilder von vorne auf dem Bildschirm. Ansicht von der Seite kann zu Ermüdung oder Überanstrengung der Augen führen.

### **Zum Urheberrecht von original projizierten Bildern:**

Bitte beachten Sie, dass bei der Verwendung dieses Projektors für kommerzielle Zwecke oder zur Erregung der Aufmerksamkeit an einem öffentlichen Ort, z. B. in einem Café oder in einem Hotel, eine Komprimierung oder Dehnung des Bildes mit den Funktionen als Verletzung bestehender und gesetzlich geschützter Urheberrechte ausgelegt werden kann.

[BILDFORMAT], Vergrößerungs- und andere ähnliche Funktionen.



# Table of Contents

---

<b>Introduction</b> .....	b
<b>Important Information</b> .....	i
<b>Wichtige Informationen</b> .....	xii
<b>1. Before Setting Up Your Projector</b> .....	1
1-1. Clearance for Installing the Projector (English) .....	1
1-2. Freiraum bei der Projektorinstallation (Deutsch).....	3
1-3. Selecting the lens unit .....	5
1-4. Carrying the projector .....	12
1-5. Removing and Mounting the Projector Covers.....	13
1-5-1. Removing and Mounting the Lens Cover.....	15
1-5-2. Removing and Mounting the Side Panel .....	17
1-5-3. Removing and Mounting the Filter Cover .....	17
1-6. Selecting the Power Cable for C2 Connection (English).....	18
1-7. Auswahl des Netzkabels für Anschluss C2 (Deutsch) .....	21
1-8. Connecting the power cable (English) .....	24
1-8-1. Power supply construction specifications .....	24
1-8-2. Procedure for connecting the power cable (C1 connection).....	31
1-8-3. Procedure for connecting the power cable (C2 connection).....	34
1-9. Anschließen des Netzkabels (Deutsch).....	38
1-9-1. Technische Daten zum Netzanschluss .....	38
1-9-2. Anschluss des Stromkabels (Anschluss C1).....	45
1-9-3. Anschluss des Stromkabels (Anschluss C2).....	48
<b>2. Configuring the projector's initial settings</b> .....	52
2-1. Initial settings flow.....	52
2-2. Updating the software .....	52
2-2-1. Update flow.....	52
2-2-2. Installing the DCC on the computer.....	53
2-2-3. Connecting the computer to the projector and starting up the DCC .....	54
2-2-4. Updating the projector .....	56
2-2-5. Exiting the DCC .....	58
2-3. Installing the LV unit .....	59
2-4. Attaching the controls/indicator panel display label .....	61
<b>3. Setting Up Your Projector</b> .....	62
3-1. Setup Procedure .....	62
3-2. Installing the projector .....	63
3-3. Mounting the Lens Unit .....	64
<b>4. Projector Adjustment and Connecting</b> .....	69
4-1. Flow of Adjustment and Connecting .....	69
4-2. Turning on the Projector .....	70
4-3. Selecting the projector orientation.....	74

4-4. Adjusting the Picture Size and Position .....	75
4-4-1. Adjustment of the projector's settings (Level adjusters).....	76
4-4-2. Adjusting the vertical position of a projected image (Lens shift) .....	77
4-4-3. Focus .....	79
4-4-4. Zoom.....	81
4-5. Connecting to Other Equipments .....	82
4-5-1. Connecting to external equipments .....	82
4-5-2. Mounting the Optional Board (sold separately).....	84
4-6. Turning off the Projector.....	85
<b>5. List of Menu Items .....</b>	<b>87</b>
<b>6. Maintenance .....</b>	<b>93</b>
6-1. Cleaning the Cabinet .....	93
6-2. Cleaning the Lens .....	93
6-3. Cleaning the Air Filters .....	94
6-3-1. Cleaning the Air Filter .....	94
6-3-2. Resetting the Air Filter Usage Time.....	97
<b>7. Appendix.....</b>	<b>98</b>
7-1. Compatible Input Signal List .....	98
7-2. Indicator Messages .....	100
7-3. Pin assignments and signal names of main terminals.....	103
7-4. Remote Interlock Connector .....	108
7-5. About the ASCII Control Command .....	110
7-6. Outline Drawing .....	112
7-7. Special Installation .....	113
7-7-1. Installing the Projector on the Ceiling .....	113
7-7-2. Installing using eye bolts .....	114
7-7-3. Installation for free tilting or portrait projecting.....	115
7-7-4. Multi-Screen Projection .....	117
7-8. Using the DCC's functions.....	118
7-8-1. Description of the Sections in the screen .....	118
7-8-2. Switching the operating mode .....	122
7-8-3. Checking Information of the Projector and Logs .....	124
7-8-4. Creating logs .....	134

# 1. Before Setting Up Your Projector

## 1-1. Clearance for Installing the Projector (English)

Allow ample clearance between the projector and its surroundings as shown below. The high temperature exhaust coming out of the device may be sucked into the device again. Avoid installing the projector in a place where air movement from the HVAC is directed at the projector. Heated air from the HVAC can be taken in by the projector's intake vent. If this happens, the temperature inside the projector will rise too high causing the over-temperature protector to automatically turn off the projectors power.

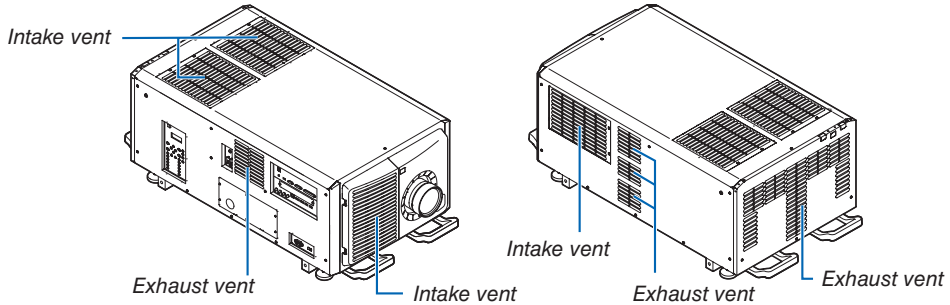

### Installation conditions for the projector

#### Example 1 – If there are walls on both sides of the projector.

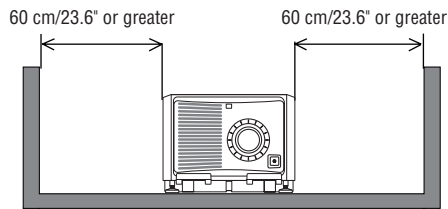

**NOTE:**

- The drawing shows the proper clearance required for the front, back, and top of the projector.
- The above drawing can also be applied to the required clearance between intake vent and the floor for the portrait projection.
- See page 115 for an installation example on portrait projection.

#### Example 2 – If there is a wall behind the projector.

##### (1) For floor installation:

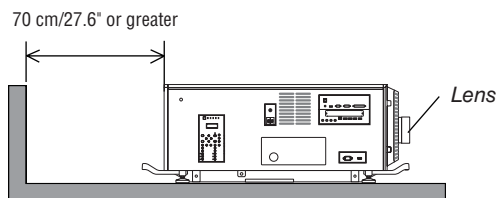

**NOTE:**

- The drawing shows the proper clearance required for the right, left, and top of the projector.

## 1. Before Setting Up Your Projector

### (2) For ceiling mounting:

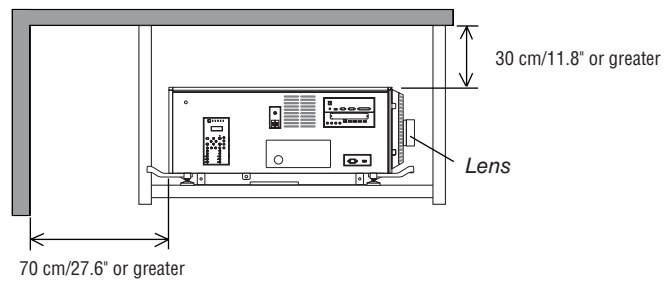

**NOTE:**

- The drawing shows the proper clearance required for the front, right, left, and bottom of the projector.

### 1-2. Freiraum bei der Projektorinstallation (Deutsch)

Sorgen Sie für ausreichend Abstand zwischen dem Projektor und der Umgebung wie unten abgebildet. Die mit hoher Temperatur aus dem Gerät ausströmende Abluft könnte wieder in das Gerät eingesaugt werden. Installieren Sie den Projektor nicht in einer Position, wo die Luft aus einer Klimaanlage auf den Projektor trifft. Heiße Luft aus einer Klimaanlage kann von den Lüftungsöffnungen des Projektors aufgenommen werden. In diesem Fall steigt die Innentemperatur des Projektors zu hoch und der Überhitzungsschutz wird den Projektor abschalten.

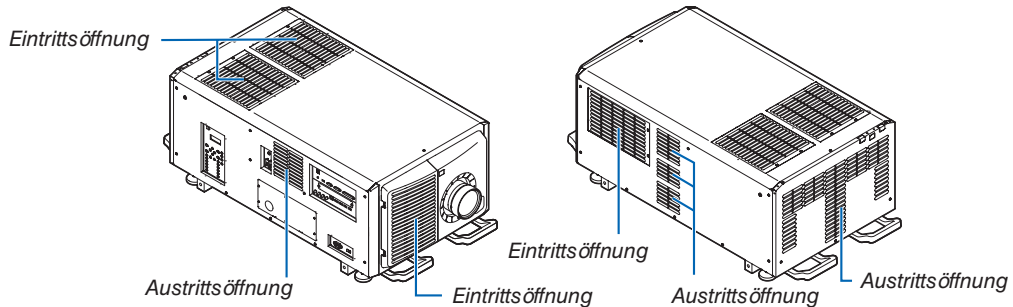

#### Bedingungen für die Installation des Projektors

##### Beispiel 1 – Wenn sich Wände auf beiden Seiten des Projektors befinden.

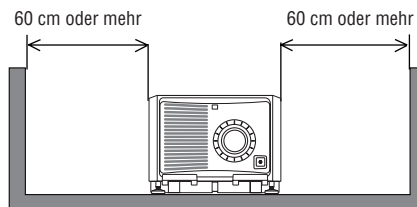

#### HINWEIS:

- Die Abbildung zeigt den ordnungsgemäßen Abstand für die Vorder-, Rück- und Oberseite des Projektors.
- Die obige Zeichnung kann auch für den erforderlichen Abstand zwischen der Eintrittsöffnung und dem Boden bei der Ausrichtung im Hochformat verwendet werden.
- Ein Einbaubeispiel für die Projektion im Hochformat finden Sie auf Seite 115.

##### Beispiel 2 – Wenn sich eine Wand hinter dem Projektor befindet.

###### (1) Für Bodeninstallation:

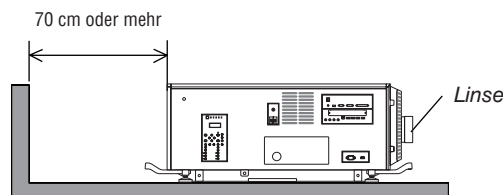

#### HINWEIS:

- Die Zeichnung zeigt den richtigen Abstand des Projektors nach rechts, links und oben an.

## 1. Before Setting Up Your Projector

### (2) Für Deckenmontage:

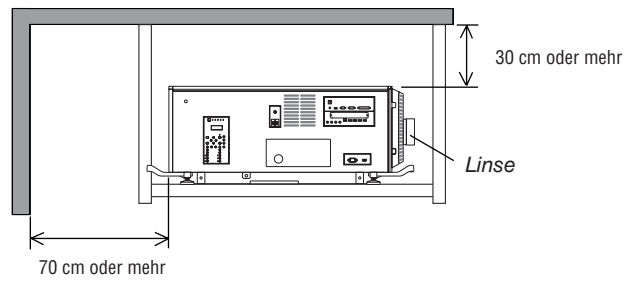

#### HINWEIS:

- Die Zeichnung zeigt den richtigen Abstand des Projektor nach vorn, rechts, links und unten an.

### 1-3. Selecting the lens unit

This section provides the guideline information on how to select a screen size, projector mounting position, and type of lens units, which is appropriate for your presentation purposes. Many types of optical lens for the projector are available for separate sale to support various projection range.

Note that all descriptions given in this manual assume that the angle of projection is zero degree. In case of projection from an upper position or from the right or left, it is necessary to calculate the width for the minimum projected image that is a little larger than the screen size.

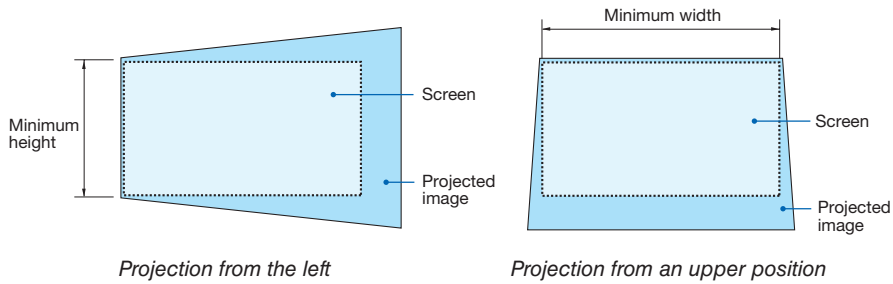

## 1. Before Setting Up Your Projector

### Throw distance and screen size

Seven separate bayonet style lenses can be used on this projector. Refer to the information on this page and use a lens suited for the installation environment (screen size and throw distance). For installation and replacement of lens units contact your distributor.

Each number provided in the table below means the throw distance between the lens surface and the screen.

### Lens types and throw distance

4096 × 2160 (Aspect ratio: 17:9)

unit: inch

Screen size	Lens model name						
	L2K-10F1	L4K-11ZM	L4K-15ZM	L4K-20ZM	L2K-30ZM	L2K-43ZM1	L2K-55ZM1
100"	78.7	105.9–149.6	131.2–181.1	185.0–303.1	232.3–338.6	338.6–476.4	433.1–677.2
120"	94.5	128.0–181.1	158.4–220.5	216.5–362.2	279.5–409.4	405.5–574.8	519.7–818.9
150"	122.0	161.2–224.4	199.1–275.6	271.7–448.8	354.3–511.8	511.8–720.5	653.5–1027.6
200"	161.4	216.6–303.1	267.0–370.1	358.3–598.4	476.4–689.0	685.0–968.5	874.0–1374.0
250"	204.7	271.9–378.0	334.8–460.6	444.9–744.1	594.5–862.2	858.3–1212.6	1098.4–1720.5
300"	244.1	327.2–456.7	402.7–555.1	531.5–889.8	716.5–1035.4	1031.5–1456.7	1318.9–2070.9
350"	287.4	382.5–492.1	470.5–649.6	618.1–1039.4	838.6–1212.6	1208.7–1704.7	1543.3–2417.3
400"	326.8	437.9–610.2	538.4–744.1	704.7–1185.0	956.7–1385.8	1381.9–1948.8	1763.8–2763.8
500"	409.4	548.5–763.8	674.1–929.1	878.0–1476.4	1200.8–1736.2	1728.3–2440.9	2208.7–3460.6
600"	492.1	659.2–917.3	809.8–1118.1	1051.2–1771.7	1440.9–2086.6	2078.7–2929.1	2653.5–4153.5
800"	657.5	880.5–1224.4	1081.2–1492.1	1397.6–2358.3	1925.2–2783.5	2775.6–3913.4	3543.3–5547.2
1000"	822.8	1101.8–1531.5	1352.6–1866.1	1744.1–2944.9	2409.4–3484.3	3468.5–4893.7	4433.1–6937.0

unit: m

Screen size	Lens model name						
	L2K-10F1	L4K-11ZM	L4K-15ZM	L4K-20ZM	L2K-30ZM	L2K-43ZM1	L2K-55ZM1
100"	2.0	2.7–3.8	3.3–4.6	4.7–7.7	5.9–8.6	8.6–12.1	11.0–17.2
120"	2.4	3.3–4.6	4.0–5.6	5.5–9.2	7.1–10.4	10.3–14.6	13.2–20.8
150"	3.1	4.1–5.7	5.1–7.0	6.9–11.4	9.0–13.0	13.0–18.3	16.6–26.1
200"	4.1	5.5–7.7	6.8–9.4	9.1–15.2	12.1–17.5	17.4–24.6	22.2–34.9
250"	5.2	6.9–9.6	8.5–11.7	11.3–18.9	15.1–21.9	21.8–30.8	27.9–43.7
300"	6.2	8.3–11.6	10.2–14.1	13.5–22.6	18.2–26.3	26.2–37.0	33.5–52.6
350"	7.3	9.7–12.5	12.0–16.5	15.7–26.4	21.3–30.8	30.7–43.3	39.2–61.4
400"	8.3	11.1–15.5	13.7–18.9	17.9–30.1	24.3–35.2	35.1–49.5	44.8–70.2
500"	10.4	13.9–19.4	17.1–23.6	22.3–37.5	30.5–44.1	43.9–62.0	56.1–87.9
600"	12.5	16.7–23.3	20.6–28.4	26.7–45.0	36.6–53.0	52.8–74.4	67.4–105.5
800"	16.7	22.4–31.1	27.5–37.9	35.5–59.9	48.9–70.7	70.5–99.4	90.0–140.9
1000"	20.9	28.0–38.9	34.4–47.4	44.3–74.8	61.2–88.5	88.1–124.3	112.6–176.2

### TIP

- Calculation of the throw distance from the screen size

L2K-10F1 lens throw distance (m) =  $H \times 0.93$  : 78.7"/2.0 m (min.) to 822.8"/20.9 m (max.)

L4K-11ZM lens throw distance (m) =  $H \times 1.24$  to  $H \times 1.73$  : 105.9"/2.7 m (min.) to 1531.5"/38.9 m (max.)

L4K-15ZM lens throw distance (m) =  $H \times 1.52$  to  $H \times 2.10$  : 131.2"/3.3 m (min.) to 1866.1"/47.4 m (max.)

L4K-20ZM lens throw distance (m) =  $H \times 1.98$  to  $H \times 3.34$  : 185.0"/4.7 m (min.) to 2944.9"/74.8 m (max.)

L2K-30ZM lens throw distance (m) =  $H \times 2.71$  to  $H \times 3.92$  : 232.3"/5.9 m (min.) to 3484.3"/88.5 m (max.)

L2K-43ZM1 lens throw distance (m) =  $H \times 3.91$  to  $H \times 5.52$  : 338.6"/8.6 m (min.) to 4893.7"/124.3 m (max.)

L2K-55ZM1 lens throw distance (m) =  $H \times 4.99$  to  $H \times 7.82$  : 433.1"/11.0 m (min.) to 6937.0"/176.2 m (max.)

"H" (Horizontal) refers to the screen width.

\* Figures differ by several % with the table above because the calculation is approximate.

Ex.: Throw distance when projecting on a 300" screen using the L4K-15ZM lens:

According to the "Tables of screen sizes and dimensions" in case of 4096 × 2160 (Aspect Ratio 17:9) (→ page 9), H (screen width) = 265.4"/6.74 m.

The throw distance is 265.4"/6.74 m × 1.52 to 265.4"/6.74 m × 2.10 = 403.41"/10.24 m to 557.34"/14.15 m (because of the zoom lens).



# 1. Before Setting Up Your Projector

3840 × 2160 (Aspect ratio: 16:9)

unit: inch

Screen size	Lens model name						
	L2K-10F1	L4K-11ZM	L4K-15ZM	L4K-20ZM	L2K-30ZM	L2K-43ZM1	L2K-55ZM1
100"	82.7	111.5–157.5	138.2–192.9	192.9–318.9	244.1–354.3	354.3–500.0	452.8–712.6
120"	102.4	134.9–189.0	166.6–232.3	228.3–381.9	295.3–429.1	429.1–602.4	547.2–858.3
150"	126.0	169.8–240.2	209.2–291.3	283.5–472.4	370.1–539.4	535.4–759.8	689.0–1078.7
200"	169.3	228.0–318.9	280.3–389.8	374.0–629.9	500.0–720.5	720.5–1015.7	921.3–1444.9
250"	212.6	286.3–401.6	351.3–488.2	464.6–783.5	626.0–905.5	901.6–1275.6	1153.5–1811.0
300"	255.9	344.6–480.3	422.3–586.6	555.1–937.0	752.0–1090.6	1086.6–1531.5	1385.8–2173.2
350"	299.2	402.8–559.1	493.3–685.0	645.7–1090.6	881.9–1271.7	1267.7–1791.3	1622.0–2539.4
400"	342.5	461.1–641.7	564.4–783.5	736.2–1248.0	1007.9–1456.7	1452.8–2047.2	1854.3–2905.5
500"	433.1	577.5–803.1	706.4–976.4	921.3–1555.1	1259.8–1822.8	1818.9–2563.0	2322.8–3637.8
600"	519.7	694.1–964.6	848.4–1173.2	1102.4–1862.2	1515.7–2192.9	2185.0–3078.7	2787.4–4366.1
800"	692.9	927.1–1287.4	1132.5–1566.9	1464.6–2480.3	2023.6–2925.2	2917.3–4110.2	3724.4–5830.7
1000"	866.1	1160.0–1610.2	1416.6–1960.6	1830.7–3098.4	2531.5–3661.4	3645.7–5141.7	4657.5–7291.3

unit: m

Screen size	Lens model name						
	L2K-10F1	L4K-11ZM	L4K-15ZM	L4K-20ZM	L2K-30ZM	L2K-43ZM1	L2K-55ZM1
100"	2.1	2.8–4.0	3.5–4.9	4.9–8.1	6.2–9.0	9.0–12.7	11.5–18.1
120"	2.6	3.4–4.8	4.2–5.9	5.8–9.7	7.5–10.9	10.9–15.3	13.9–21.8
150"	3.2	4.3–6.1	5.3–7.4	7.2–12.0	9.4–13.7	13.6–19.3	17.5–27.4
200"	4.3	5.8–8.1	7.1–9.9	9.5–16.0	12.7–18.3	18.3–25.8	23.4–36.7
250"	5.4	7.3–10.2	8.9–12.4	11.8–19.9	15.9–23.0	22.9–32.4	29.3–46.0
300"	6.5	8.8–12.2	10.7–14.9	14.1–23.8	19.1–27.7	27.6–38.9	35.2–55.2
350"	7.6	10.2–14.2	12.5–17.4	16.4–27.7	22.4–32.3	32.2–45.5	41.2–64.5
400"	8.7	11.7–16.3	14.3–19.9	18.7–31.7	25.6–37.0	36.9–52.0	47.1–73.8
500"	11.0	14.7–20.4	17.9–24.8	23.4–39.5	32.0–46.3	46.2–65.1	59.0–92.4
600"	13.2	17.6–24.5	21.6–29.8	28.0–47.3	38.5–55.7	55.5–78.2	70.8–110.9
800"	17.6	23.5–32.7	28.8–39.8	37.2–63.0	51.4–74.3	74.1–104.4	94.6–148.1
1000"	22.0	29.5–40.9	36.0–49.8	46.5–78.7	64.3–93.0	92.6–130.6	118.3–185.2

**TIP**

- Calculation of the throw distance from the screen size

L2K-10F1 lens throw distance (m) =  $H \times 0.99$  : 82.7"/2.1 m (min.) to 866.1"/22.0 m (max.)

L4K-11ZM lens throw distance (m) =  $H \times 1.33$  to  $H \times 1.84$  : 111.5"/2.8 m (min.) to 1610.2"/40.9 m (max.)

L4K-15ZM lens throw distance (m) =  $H \times 1.62$  to  $H \times 2.24$  : 138.2"/3.5 m (min.) to 1960.6"/49.8 m (max.)

L4K-20ZM lens throw distance (m) =  $H \times 2.11$  to  $H \times 3.57$  : 192.9"/4.9 m (min.) to 3098.4"/78.7 m (max.)

L2K-30ZM lens throw distance (m) =  $H \times 2.89$  to  $H \times 4.19$  : 244.1"/6.2 m (min.) to 3661.4"/93.0 m (max.)

L2K-43ZM1 lens throw distance (m) =  $H \times 4.17$  to  $H \times 5.88$  : 354.3"/9.0 m (min.) to 5141.7"/130.6 m (max.)

L2K-55ZM1 lens throw distance (m) =  $H \times 5.33$  to  $H \times 8.34$  : 452.8"/11.5 m (min.) to 7291.3"/185.2 m (max.)

"H" (Horizontal) refers to the screen width.

\* Figures differ by several % with the table above because the calculation is approximate.

Ex.: Throw distance when projecting on a 300" screen using the L4K-15ZM lens:

According to the "Tables of screen sizes and dimensions" in case of 3840 × 2160 (Aspect Ratio 16:9) (→ page 9), H (screen width) = 261.5"/6.64 m.

The throw distance is  $261.5"/6.64 \text{ m} \times 1.62$  to  $261.5"/6.64 \text{ m} \times 2.24 = 423.63"/10.76 \text{ m}$  to  $585.76"/14.87 \text{ m}$  (because of the zoom lens).

Projection range for the different lenses

4096 × 2160 (Aspect ratio: 17:9)

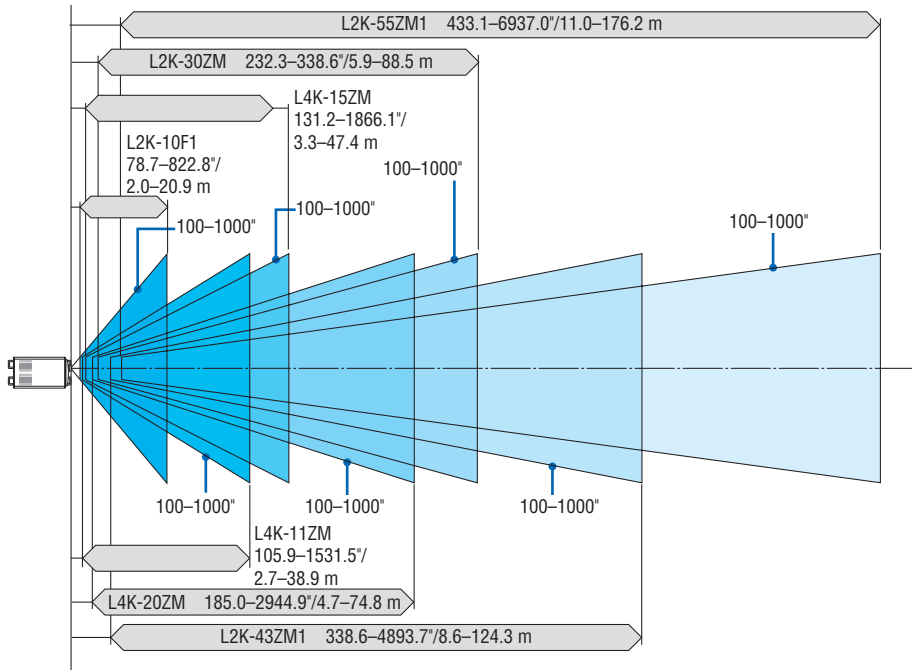

3840 × 2160 (Aspect ratio: 16:9)

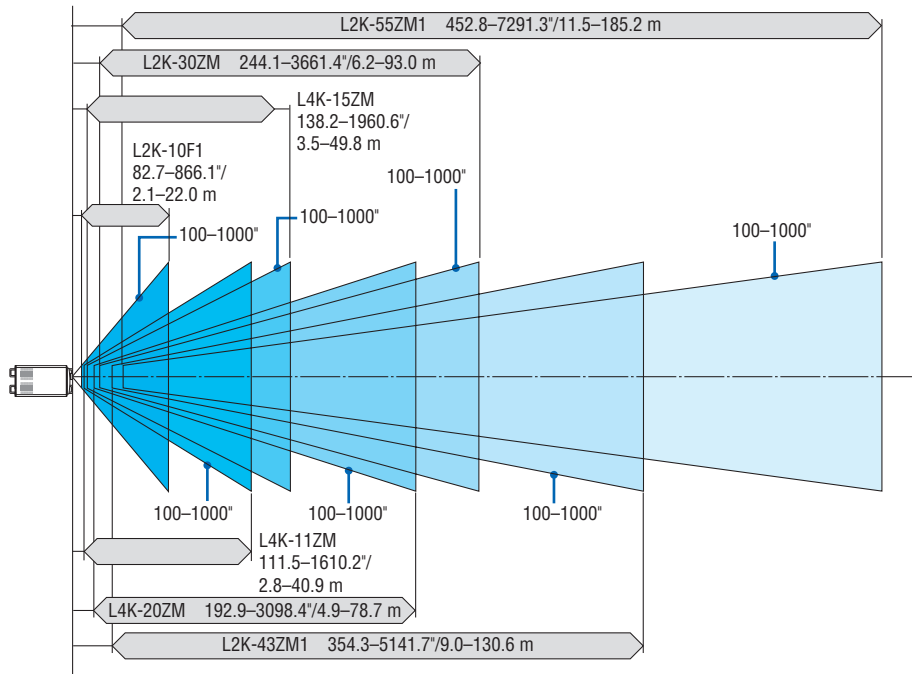

## 1. Before Setting Up Your Projector

### Tables of screen sizes and dimensions

#### 4096 x 2160 (Aspect ratio: 17:9)

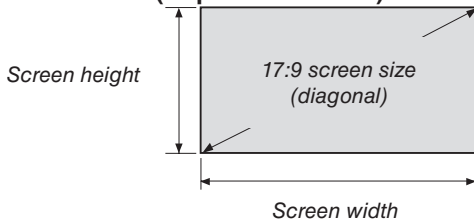

Size (inches)	Screen width		Screen height	
	(inches)	(cm)	(inches)	(cm)
100	88.5	224.7	46.6	118.5
120	106.1	269.6	56.0	142.2
150	132.7	337.0	70.0	177.7
200	176.9	449.3	93.3	237.0
250	221.1	561.7	116.6	296.2
300	265.4	674.0	139.9	355.4
350	309.6	786.4	163.3	414.7
400	353.8	898.7	186.6	473.9
450	398.0	1011.0	209.9	533.2
500	442.3	1123.4	233.2	592.4
550	486.5	1235.7	256.6	651.6
600	530.7	1348.0	279.9	710.9
650	575.0	1460.4	303.2	770.1
700	619.2	1572.7	326.5	829.4
750	663.4	1685.1	349.8	888.6
800	707.6	1797.4	373.2	947.8
850	751.9	1909.7	396.5	1007.1
900	796.1	2022.1	419.8	1066.3
950	840.3	2134.4	443.1	1125.6
1000	884.5	2246.7	466.5	1184.8

#### 3840 x 2160 (Aspect ratio: 16:9)

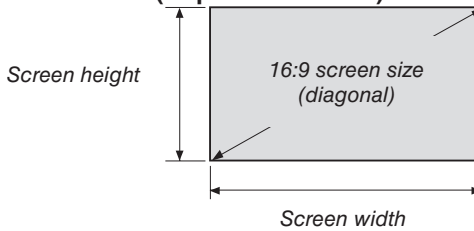

Size (inches)	Screen width		Screen height	
	(inches)	(cm)	(inches)	(cm)
100	87.2	221.4	49.0	124.5
120	104.6	265.7	58.8	149.4
150	130.7	332.1	73.5	186.8
200	174.3	442.8	98.1	249.1
250	217.9	553.5	122.6	311.3
300	261.5	664.1	147.1	373.6
350	305.1	774.8	171.6	435.8
400	348.6	885.5	196.1	498.1
450	392.2	996.2	220.6	560.4
500	435.8	1106.9	245.1	622.6
550	479.4	1217.6	269.6	684.9
600	522.9	1328.3	294.2	747.2
650	566.5	1439.0	318.7	809.4
700	610.1	1549.7	343.2	871.7
750	653.7	1660.4	367.7	933.9
800	697.3	1771.0	392.2	996.2
850	740.8	1881.7	416.7	1058.5
900	784.4	1992.4	441.2	1120.7
950	828.0	2103.1	465.7	1183.0
1000	871.6	2213.8	490.3	1245.3

## Lens shifting range

This projector is equipped with a lens shift function for adjusting the position of the projected image by using the LENS SHIFT buttons (→ page 77). The lens can be shifted within the range shown below.

**NOTE:**

- Please do not use the lens shift function when projecting portrait images. Please use it with the lens in the center.

Legend: V “Vertical” refers to the screen height and H “Horizontal” refers to the screen width. The lens shift range is expressed as a ratio of height and width, respectively.

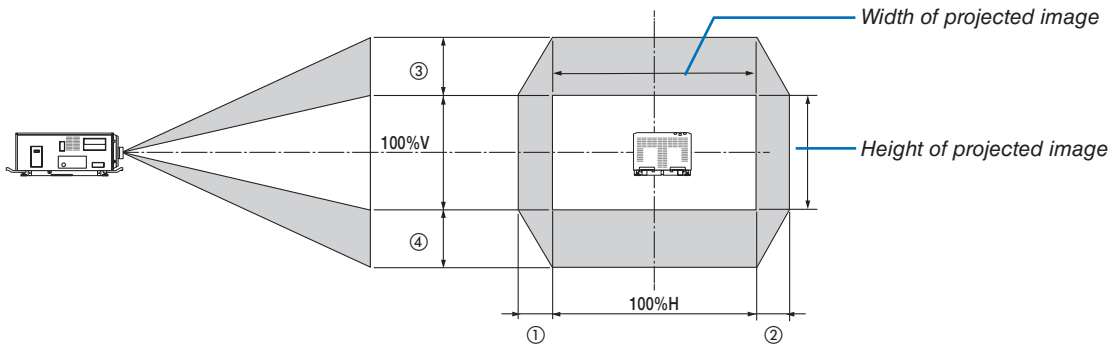

\* The lens shift range is the same for ceiling installation.

### 4096 × 2160 (Aspect ratio: 17:9)

Lens unit	Drawing number	
	①②	③④
L2K-10F1	8%H	27%V
L4K-11ZM	17%H	50%V
L4K-15ZM	17%H	50%V
L4K-20ZM	17%H	50%V
L2K-30ZM	8%H	27%V
L2K-43ZM1	8%H	27%V
L2K-55ZM1	10%H	31%V

(Example calculation) If projecting on a 300 inch screen using an L4K-15ZM lens unit  
 According to the “Table of screen sizes and dimensions” (→ page 9),  $H = 265.4"/674.0 \text{ cm}$ ,  $V = 139.9"/355.4 \text{ cm}$ .  
 Adjustment range in the vertical direction: the projected image can be moved upwards  $0.5 \times 139.9"/355.4 \text{ cm} \approx 70"/178 \text{ cm}$ , downwards approximately  $70"/178 \text{ cm}$  (when the lens is at the center position).  
 Adjustment range in the horizontal direction: the projected image can be moved to the left  $0.17 \times 265.4"/674.0 \text{ cm} \approx 45"/115 \text{ cm}$ , to the right approximately  $45"/115 \text{ cm}$ .

\* Figures differ by several % because the calculation is approximate.

### 3840 × 2160 (Aspect ratio: 16:9)

Lens unit	Drawing number	
	①②	③④
L2K-10F1	12%H	34%V
L4K-11ZM	22%H	55%V
L4K-15ZM	22%H	55%V
L4K-20ZM	22%H	55%V
L2K-30ZM	12%H	34%V
L2K-43ZM1	12%H	34%V
L2K-55ZM1	14%H	37%V

(Example calculation) If projecting on a 300 inch screen using an L4K-15ZM lens unit

According to the "Table of screen sizes and dimensions" (→ page 9),  $H = 261.5''/664.1$  cm,  $V = 147.1''/373.6$  cm.

Adjustment range in the vertical direction: the projected image can be moved upwards  $0.55 \times 147.1''/373.6$  cm  $\approx 81''/205$  cm, downwards approximately  $81''/205$  cm (when the lens is at the center position). Adjustment range in the horizontal direction: the projected image can be moved to the left  $0.22 \times 261.5''/664.1$  cm  $\approx 58''/146$  cm, to the right approximately  $58''/146$  cm.

\* Figures differ by several % because the calculation is approximate.

### 1-4. Carrying the projector

**⚠ WARNING**

- When moving the projector, it should be carried by holding the handles or hook on the base of the unit by 6 or more people.
- When moving the projector, first turn off the power and always disconnect the power plug from the electrical outlet, and check that all of the connecting cables between equipment and the lenses have been removed.
- For C1 connection, turn off the projector, shut down AC power by using a circuit breaker.
- For C2 connection, turn off the projector, shut down the AC power to the projector and the light using a circuit breaker.

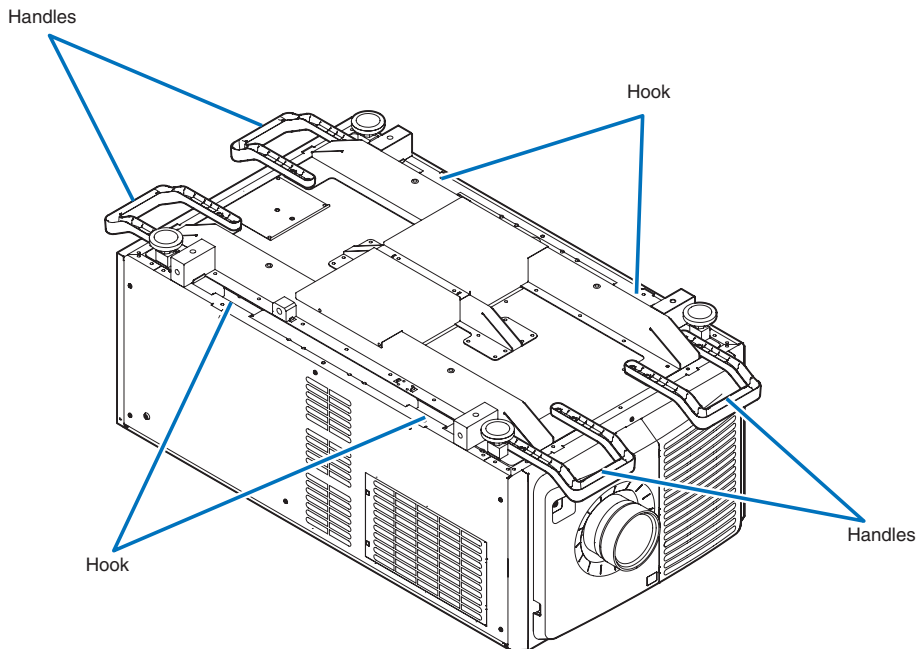

### 1-5. Removing and Mounting the Projector Covers

This section provides guideline information on how to remove and mount covers on the projector.

#### Name of the cover

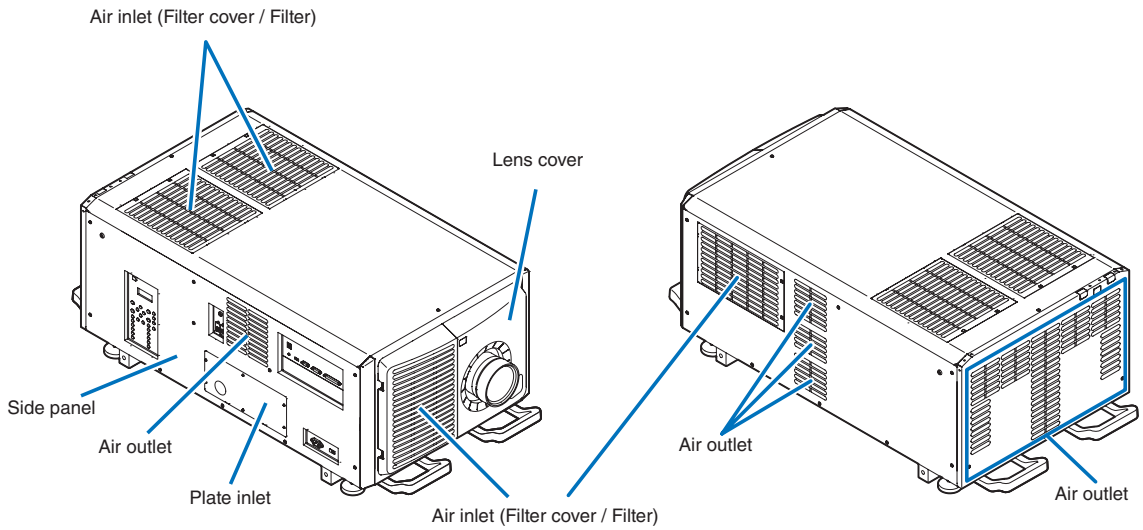

---

#### NOTE:

- “Side panel” and “Lens cover” are equipped with key locks. Special keys (service key) are required to remove or mount them. Refer to “Position of the key locks on the covers” (→ page 14) for details.
  - Do not turn on the power when the lens cover and the side panel are removed.
  - When removing the lens cover, return the lens shift to the center position before turning off the power.
-

## 1. Before Setting Up Your Projector

### Position of the key locks on the covers

When removing or attaching a cover of the projector main unit, the lock needs to be unlocked using the included service key. The positions of the locks on each of the covers are as follows.

 **WARNING**

TO REDUCE THE RISK OF ELECTRIC SHOCK AND LASER RADIATION, DO NOT OPEN COVER. NO USER-SERVICEABLE PARTS INSIDE. REFER SERVICING AND INSTALLATION TO QUALIFIED SERVICE PERSONNEL AND INSTALLATION PERSONNEL.

*NOTE:*

- *When a cover is removed, the power to the unit is automatically turned off by the safety protection system.*

### Lens Cover

The lock is unlocked when attaching or removing lenses (→ page 64).

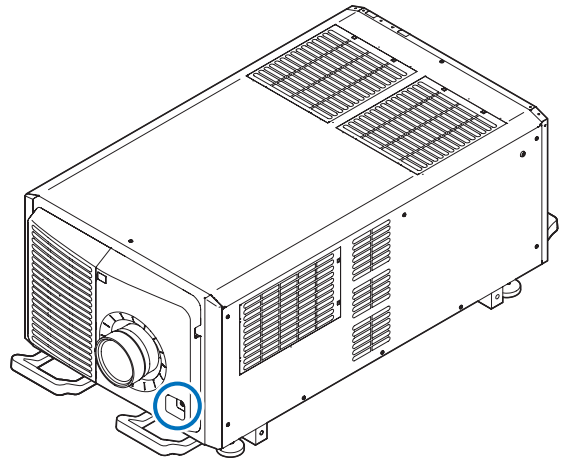

### Side Panel

The lock is unlocked when installing the LV unit (→ page 59).

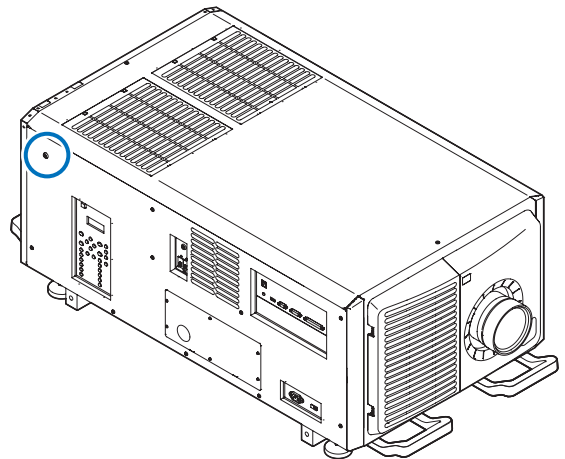



## 1. Before Setting Up Your Projector

### 1-5-1. Removing and Mounting the Lens Cover

#### Preparation:

Service key (attached goods)

#### 1. Remove the front filter cover.

*Pull the filter cover in the direction of the arrow to remove it.*

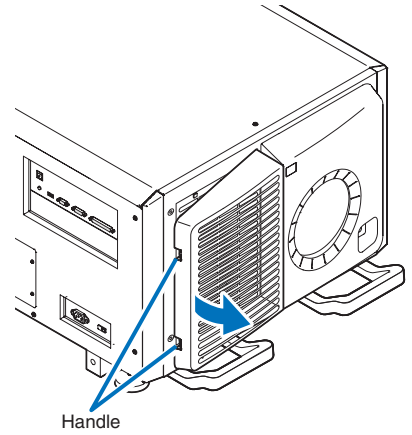

#### 2. Unlock the lens cover.

*Unlock the cover using the service key.*

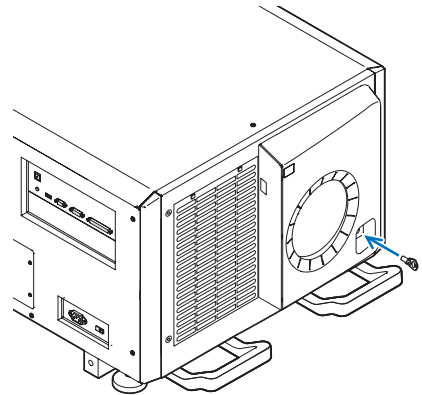

#### 3. Remove the lens cover.

*The lens cover is secured to the projector body by two claws each at the cover top and bottom.*

*Hold the cover sides and pull toward you.*

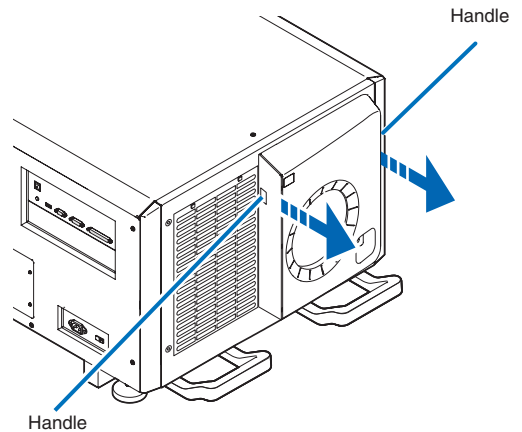

## 1. Before Setting Up Your Projector

- This completes removing the lens cover. To mount the cover, perform the removal procedure in reverse. Make sure to lock the key.

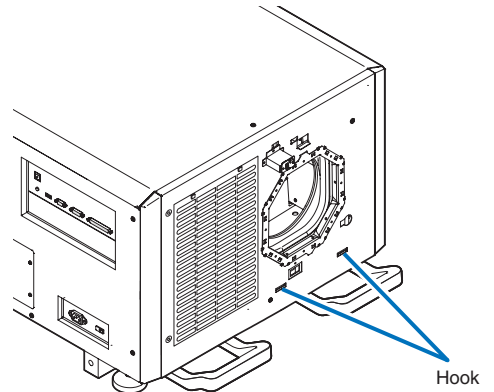

\* Lens cover removed condition

---

### NOTE:

- If the cover is not properly mounted, an error may occur. Securely push all claws into the position.
-

## 1. Before Setting Up Your Projector

### 1-5-2. Removing and Mounting the Side Panel

#### Preparation:

Phillips-head screwdriver (No.2), service key (attached goods)

#### 1. Loosen the ten fixing screws on the side panel.

Loosen four screws on the side panel until they are free to spin. The screws do not detach from the panel.

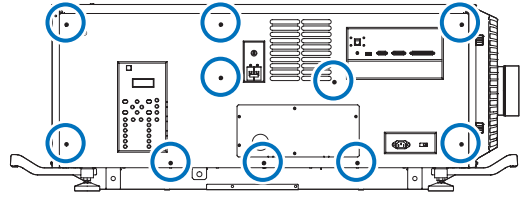

#### 2. Unlock the side panel.

Unlock the cover using the service key.

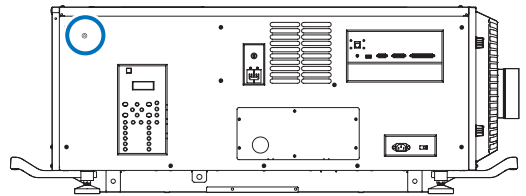

#### 3. Remove the side panel.

The side panel is fixed in place by hooks at the bottom (in 2 locations). Tilt the side panel toward you and pull up to remove it. Do not use force when tilting the side panel.

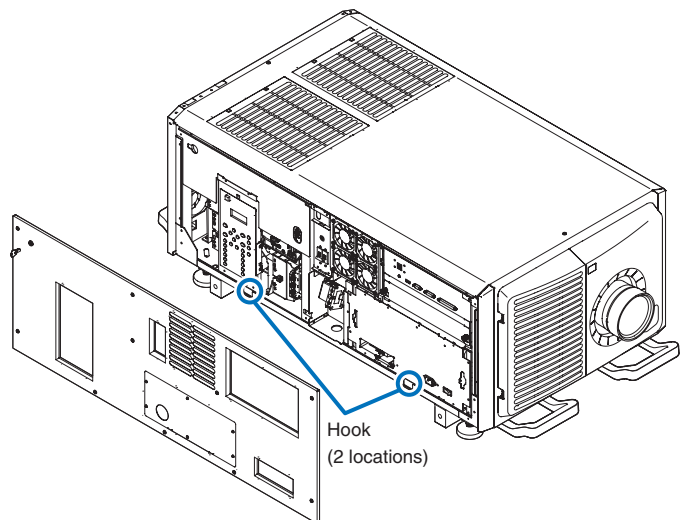

This completes removing the side panel. To mount the side panel, perform the removal procedure in reverse. Make sure that you do not forget to tighten the screws or to lock the key lock.

### 1-5-3. Removing and Mounting the Filter Cover

Refer to "6-3-1. Cleaning the Air Filter" (→ page 94) for details on how to remove and attach the filter cover.

### 1-6. Selecting the Power Cable for C2 Connection (English)

The power cable for C2 Connection is not included with the projector. Refer to “AC Power Work Specifications” ([next page](#)) and provide the necessary power cable.

#### WARNING

Carefully read the contents described in this section before connection and connect the cables according to the proper procedure. Inappropriate handling may cause fatal, serious or other bodily injuries due to fire or electric shock.

#### CAUTION

- Before connecting the power cables, check that the main power switch of the projector is turned off. Implement the connection with AC power shut off.
- Be sure to ground the equipment to ensure safety. Use a power cable that meets the standards and power supply voltage of the country where you are using the projector (→ page 19), and always connect the equipment to the ground. If the ground is not connected, it may cause electrical shocks.
- When connecting the power cable plugs to the AC IN and the electrical outlet, securely insert the plugs all the way in. If the connection between the power cable plug and the electrical outlet is loose, the plug area may generate heat, causing burns and accidents.
- In order to prevent the power plug from being disconnected from the projector, fix the power cable by using the power cable stopper supplied with this unit. For how to use the power cable stopper, refer to “Attaching the power cable stopper” (→ page 36)

#### NOTE:

- *Install the electric outlet nearby the projector main unit so that the power supply can be cut by unplugging the AC power cable.*
- *When plugging in or unplugging the AC power cable, make sure that the main power switch is pushed to the [O] position. Failure to do so may cause damage to the projector.*
- *Do not use a three-phase power supply. Doing so may cause malfunction.*

## AC Power Work Specifications

### AC power supply equipment

Do not use any voltage other than those shown below for the AC power supply connected to the projector.

200–240V AC, single phase, power, 50/60Hz

### AC power supply cable for the projector

The projector is equipped with an IEC60320-C14 inlet to connect an AC power supply cable. Use an IEC60320-C13 compliant AC power cable connector and ensure that the connector meets the following current capacity specifications.

Power supply voltage	Projector input current	Power cable current capacity
AC 200–240V	4.9A	10A or higher



Furthermore, use plugs, cables, and connectors that are suitable for the regulations of the country of installation, as shown in the following table.

#### NOTE:

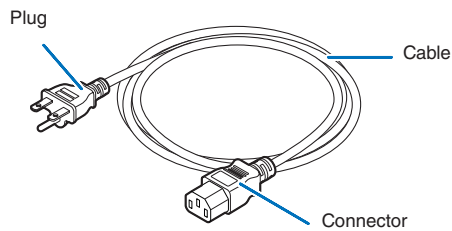

- For users in North America  
Use a power cable no longer than 4.5m/14.76 ft according to National Electrical Code.
- For UK only: In UK, a BS approved power cable with moulded plug has a black (10 Amps) fuse installed for use with this equipment. If a power cable is not supplied with this equipment, please contact your supplier.

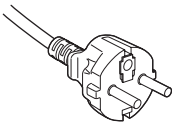

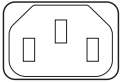
### Germany

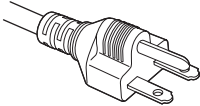

Plug	Cable	Connector
CEE 7 	H05VV-F 3 x 1 mm <sup>2</sup> 	IEC60320 C13 

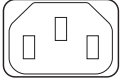
### USA

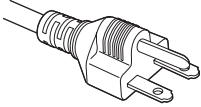

Plug	Cable	Connector
NEMA 6-15P 	SJT 3 x AWG 16 	IEC60320 C13 

## 1. Before Setting Up Your Projector

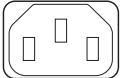
### Japan

Plug	Cable	Connector
JIS C 8303 	HVCTF 3 x 1.25 mm <sup>2</sup> 	IEC60320 C13 

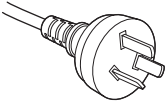
### China

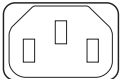
Plug	Cable	Connector
GB2099 	RVV 300/500 	GB17465.1 

### Connector

Dimensions of the connector of the power cable are shown below.

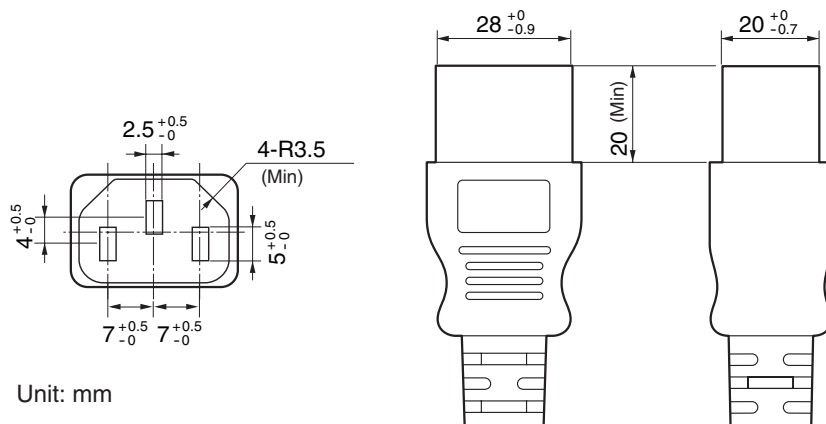

### 1-7. Auswahl des Netzkabels für Anschluss C2 (Deutsch)

Es wird kein Netzkabel für Anschluss C2 mit dem Projektor geliefert. Nehmen Sie auf „Netzstrom-Spezifikationen“ ([Nächste Seite](#)) Bezug, und beschaffen Sie das notwendige Netzkabel.

#### **WARNUNG**

Lesen Sie diesen Abschnitt vor dem Herstellen der Verbindungen sorgfältig durch, und schließen Sie die Kabel anhand der ordnungsgemäßen Verfahren an. Falsche Handhabung kann zu schweren oder sogar tödlichen Verletzungen durch Brand oder einen elektrischen Schlag führen.

#### **ACHTUNG**

- Bevor Sie das Netzkabel anschließen, prüfen Sie, ob die Hauptstromschalter des Projektors ausgeschaltet ist. Stellen Sie die Verbindungen bei ausgeschaltetem Netzstrom her.
- Erden Sie das Gerät, um die Sicherheit zu gewährleisten. Verwenden Sie ein Netzkabel, das die Normen und Netzspannung des Landes, in dem der Projektor verwendet wird, erfüllt (→ Seite 22), und schließen Sie das Gerät stets an Erde an. Wenn keine Erde angeschlossen wird, kann es zu elektrischen Schlägen kommen.
- Führen Sie die Netzkabelstecker beim Anschließen bis zum Anschlag in den Netzeingang und die Netzsteckdose ein. Sitzt der Netzstecker nicht fest in der Netzsteckdose, kann Wärme im Steckerbereich erzeugt werden, die zu Verbrennungen und Unfällen führen kann.
- Um eine Trennung des Netzsteckers vom Projektor zu verhindern, fixieren Sie das Netzkabel, indem Sie den mit diesem Gerät gelieferten Netzkabelstopper verwenden. Die Verwendung des Netzkabelstoppers siehe 50.

#### **HINWEIS:**

- *Installieren Sie die Steckdose nahe beim Projektor, so dass Sie die Stromzufuhr unterbrechen können, indem Sie das Netzkabel abtrennen.*
- *Vergewissern Sie sich, dass der Hauptstromschalter auf der Position [0] steht, bevor Sie das Netzkabel anschließen oder abziehen. Anderenfalls kann es zu einer Beschädigung des Projektors kommen.*
- *Verwenden Sie keine Dreiphasen-Stromversorgung. Anderenfalls kann es zu einer Funktionsstörung kommen.*

## Netzstrom-Spezifikationen

### Netzkabel

Der Projektor ist mit einem C19-Steckverbinder gemäß IEC60320 zum Anschließen des Netzkabels ausgestattet. Sorgen Sie dafür, dass die Netzkabel, die von den Steckverbindern am Projektor zum Netzanschluss führen, über die unten angegebenen Stromkapazitäten verfügen.

200–240 V AC, eiphasig, 50/60Hz

### Netzkabel für den Projektor



Der Projektor ist mit einem C14-Eingang gemäß IEC60320 zum Anschließen des Netzkabels ausgestattet. Verwenden Sie einen IEC60320 C13-kompatiblen Netzkabelanschluss und sorgen Sie dafür, dass der Anschluss über die unten angegebene Stromkapazität verfügt.

Netzspannung	Projektor-Eingangsstrom	Netzkabel-Stromkapazität
200–240 V Wechselstrom	4,9 A	10 A oder höher

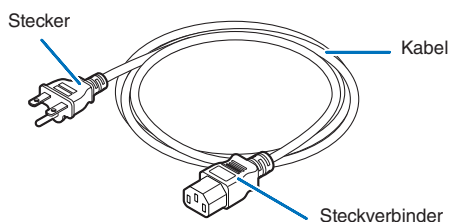

Verwenden Sie zudem Stecker, Kabel und Steckverbinder, die den Vorgaben des jeweiligen Landes entsprechen (siehe dazu folgende Tabelle).

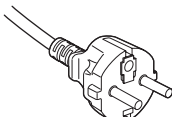

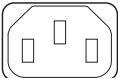
### Deutschland

Stecker	Kabel	Steckverbinder
CEE 7 	H05VV-F 3 x 1 mm <sup>2</sup> 	IEC60320 C13 

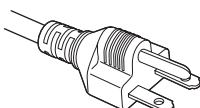

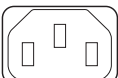
### USA

Stecker	Kabel	Steckverbinder
NEMA 6-15P 	SJT 3 x AWG 16 	IEC60320 C13 



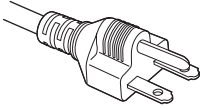

## 1. Before Setting Up Your Projector

### Japan

Stecker	Kabel	Steckverbinder
JIS C 8303 	HVCTF 3 x 1.25 mm <sup>2</sup> 	IEC60320 C13 

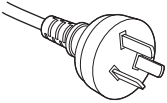
### China

Stecker	Kabel	Steckverbinder
GB2099 	RVV 300/500 	GB17465.1 

Für Benutzer in UK

Verwenden Sie ein Netzteil mit BS-Zulassung und 10A-Sicherung.

### Steckverbinder

Die Abmessungen des Netzkabels sind unten angegeben.

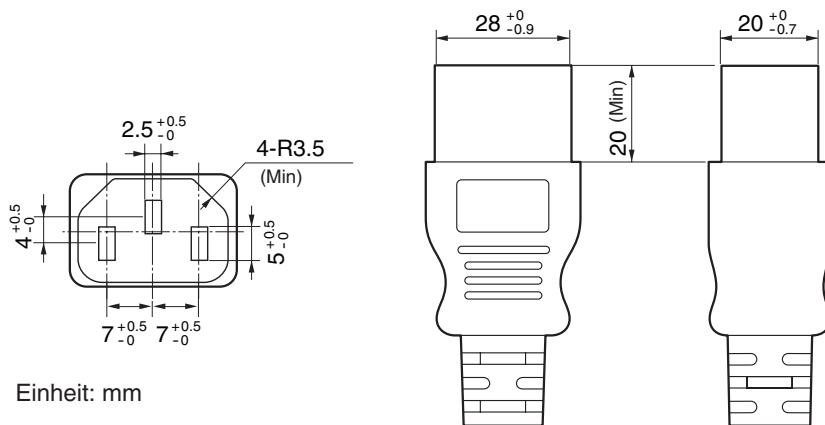

### 1-8. Connecting the power cable (English)

Connect the power cable of the projector. The AC power cable is not attached as an accessory. Be sure to have professional technicians do any power supply construction.

#### WARNING

Carefully read the contents described in this section before connection and connect the cables according to the proper procedure. Inappropriate handling may cause fatal, serious or other bodily injuries due to fire or electric shock.

#### CAUTION

- Make sure that the AC power supply is disconnected before carrying out the work of connecting the power supply cable.
- Be sure to follow the contents described in this section.
- Entrust a specialist to carry out the power supply work from the power supply equipment of the building to the place of projector installation.
- Be sure to ground the equipment to ensure safety. To avoid electric shock, request a professional to carry out the grounding and related works. Make sure to ground the equipment before supply of the AC power.

#### 1-8-1. Power supply construction specifications

There are two different ways to connect the power cables, the C1 connection and the C2 connection.

##### • C1 connection

AC power is provided to the projector power supply and the light power supply by a single cable.

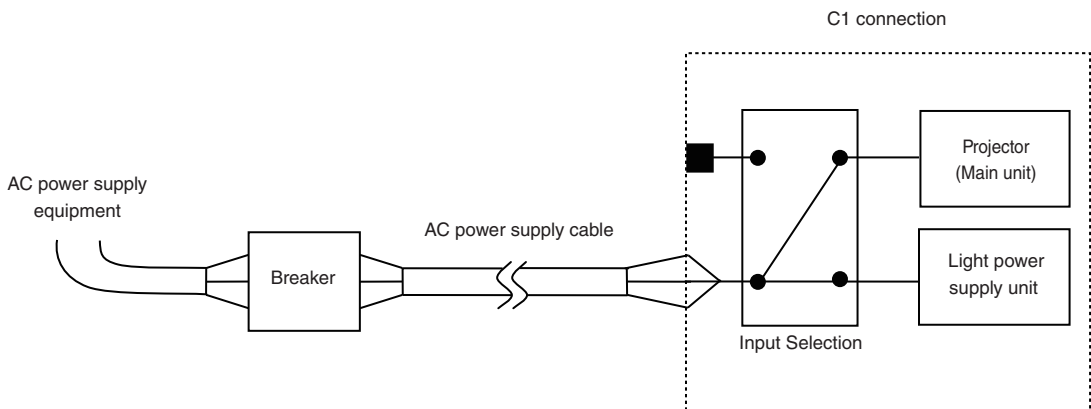

## 1. Before Setting Up Your Projector

### • C2 connection

AC power is provided to the projector power supply and the light power supply by separate cables.

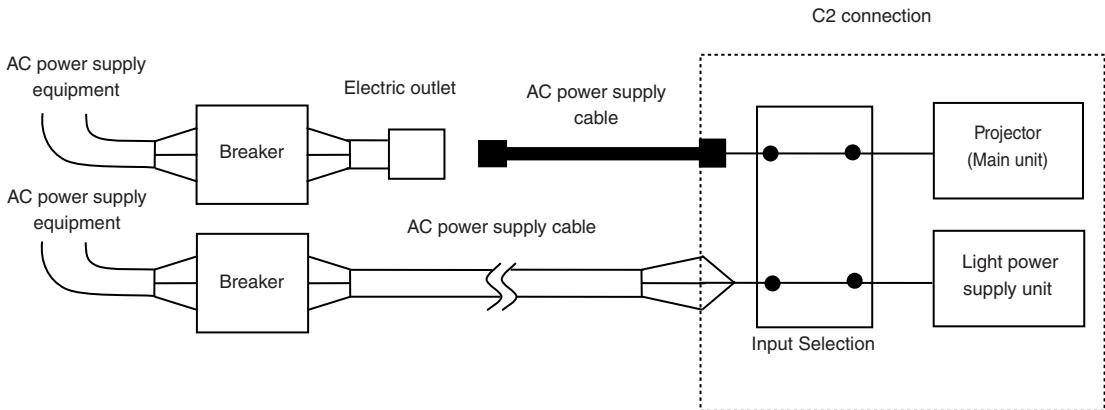

### AC power supply equipment

Do not connect AC power supply voltages to the projector other than those indicated below.

When using with a C1 connection

- 200 - 240 V AC, single phase, 50/60 Hz

When using with a C2 connection

- 200 - 240 V AC, single phase, 50/60 Hz (projector power supply)
- 200 - 240 V AC, single phase, 50/60 Hz (light power supply)

### Breakers

When connecting the AC power supply from the power supply equipment of the building to the projector, be sure to connect it through a breaker. The capacity of the breaker must be as indicated below.

When using with a C1 connection

- Power supply for projector + power supply for light  
200V-240 V AC: Input current 40A, Inrush current 150A or higher @10msec

When using with a C2 connection

- Power supply for projector  
200V-240 V AC: Input current 10A, Inrush current 60A or higher @10msec
- Power supply for light  
200V-240 V AC: Input current 40A, Inrush current 150A or higher @10msec

### Input Selection

The power supply connection method is configured by the wiring to the input selection. The configurations are as follows.

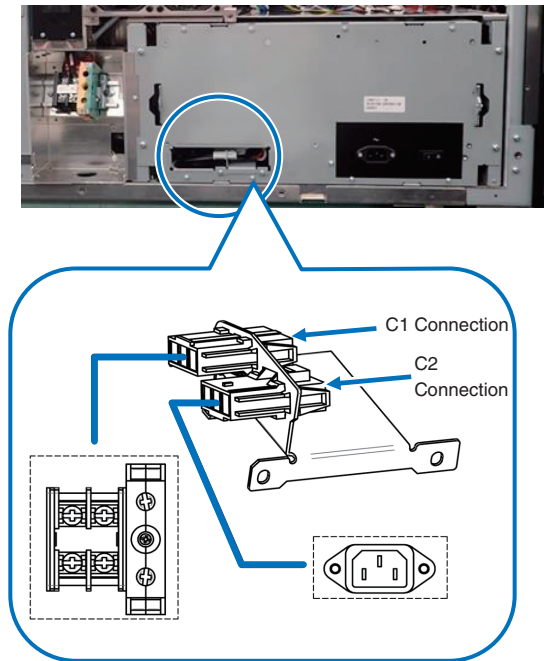

### AC power supply cable

- For the AC power cable, use a cable of thickness as appropriate for the installation country and made of copper as shown below.
- Use a round type UL-listed solderless terminal for the section connected to the main unit. In addition, when clamping this terminal with the cable, use an UL listed tool.

### Compatible Cables and Solderless Terminals

The specifications of the terminals for attaching the power cables are as follows.

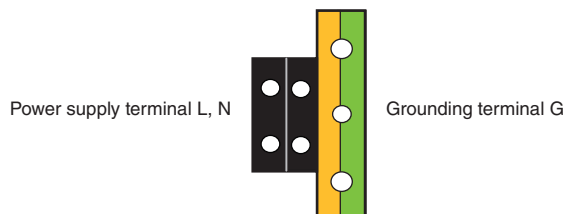

The size of the solderless terminal to use and the fastening torque of the screws varies depending on the type of terminal block. Use the cable and solderless terminal that is suitable for the specific type of terminal block as shown in the following table. This specifies the model name of the recommended solderless terminals. Use these parts or equivalent parts. If you are unable to use the recommended solderless terminals, ensure that you use terminals of the dimensions shown in the following diagram.

## 1. Before Setting Up Your Projector

### WARNING

- The power supply unit handles large electrical currents. To maintain safety, use wires with the specifications as shown in the following table, and affix to the terminals at the designated attachment torque.
- Always use solderless terminals with the dimensions as shown in the following diagram.
- The use of parts with dimensions other than as designated creates a risk of the AC power supply unit short circuiting due to the terminal block generating heat and melting because the terminal block of the light power supply unit cannot be attached correctly.

### • Power supply terminal L, N (Black)

AC power is provided to the projector power supply and the light power supply by a single cable.

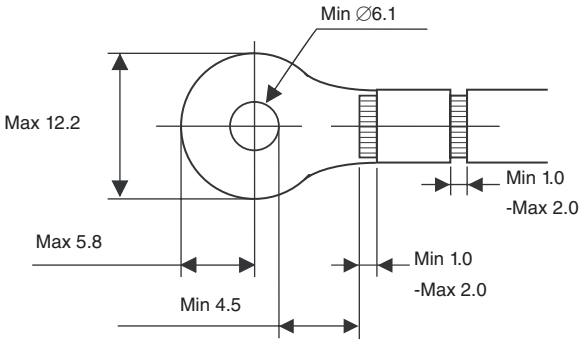
	JIS	IEC/EN	UL	CSA
Thickness of compatible wiring (using solderless terminal)	14 mm <sup>2</sup>	14 mm <sup>2</sup>	AWG6 or AWG8	AWG6 or AWG8
Solderless terminal dimensions	M5 x 10			
Tightening torque	2.0 to 2.5N·m			
Solderless terminal dimensions	 <p>Unit: mm</p>			
Solderless terminal recommended part (J.S.T parts)	Model R8-5		When using AWG6: Model R14-5 When using AWG8: Model R8-5	

J.S.T: J.S.T. Manufacturing Co. Ltd.

## 1. Before Setting Up Your Projector

### • Ground terminal G (Green/Yellow)

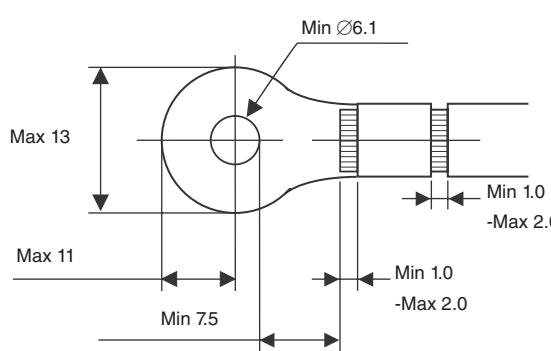
	JIS	IEC/EN	UL	CSA
Thickness of compatible wiring (using solderless terminal)	14 mm <sup>2</sup>	14 mm <sup>2</sup>	AWG6 or AWG8	AWG6 or AWG8
Solderless terminal dimensions	M6 x 15			
Tightening torque	3.5 to 5.0N·m			
Solderless terminal dimensions	 <p>Unit: mm</p>			
Solderless terminal recommended part (J.S.T parts)	Model 8-8NS		When using AWG6: Model R14-6 When using AWG8: Model 8-8NS	

J.S.T: J.S.T. Manufacturing Co. Ltd.

## 1. Before Setting Up Your Projector

### Connecting the cable

In order to attach the power cable to the connector block, connect the wires using the following procedure such that the individual wires cannot directly touch each other.

- 1. Remove the power cable sleeves from the terminals to ensure that the sleeves are not pinched by the terminal attachment screw.**

*Pull back the sleeves from the terminal area before fastening the screw to prevent the sleeves from being pinched.*

- 2. Attach the sleeves after tightening the screw.**

*Tighten the fixing screw to the designated torque.*

*Use sleeves and secure the insulation to ensure that terminals do not touch each other. If the cables are attached to the power supply terminal without using sleeves, there is a risk of the terminals touching each other as shown in the photograph on the right.*

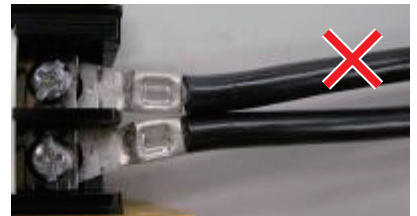
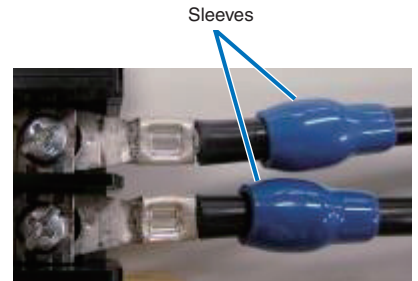

## 1. Before Setting Up Your Projector

When connecting the cables to the ground terminal block, ensure that parts other than the solderless terminal (such as cable wires and fittings) are not pinched within the terminal fastening area.

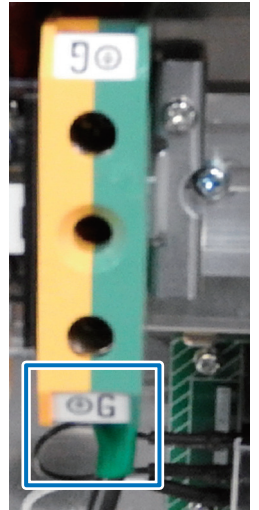

When correctly fastened.

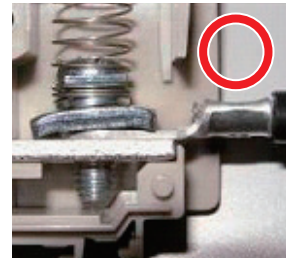

When the cable wire has become pinched due to using a solderless terminal with dimensions other than as designated.

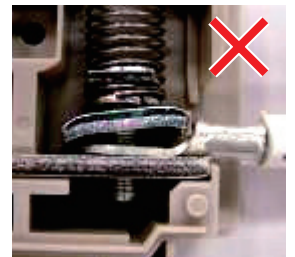



### 1-8-2. Procedure for connecting the power cable (C1 connection)

#### Preparation:

Phillips-head screwdriver (No. 2), service key (projector accessory)

#### WARNING

- Before connecting the power cable, make sure that the AC power supply is disconnected. Otherwise a fire or electric shock may occur.
- High leakage current flows. Do NOT connect the power supply before grounding connection.

#### 1. Remove the plate inlet.

Remove the plate inlet by loosening the fixing screws (at six points).

In Europe, replace it with the supplied  $\varnothing 35$  plate inlet.

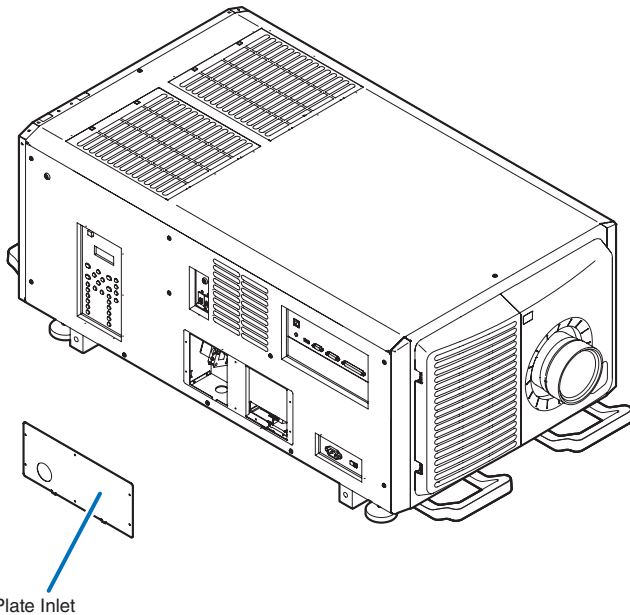

#### 2. Pass the power cable through the cable hole of the plate.

If you use the supplied  $\varnothing 35$  plate inlet, pass the power cable through a commercially available cable stopper and then insert it into the cable hole.

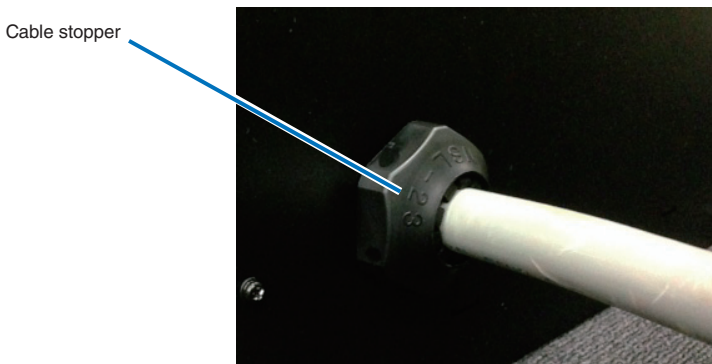

## 1. Before Setting Up Your Projector

### 3. Remove the terminal cover of the power supply terminals.

Remove the terminal cover by pulling it upward.

### 4. Insert the L/N lines of the AC power cable into the connection terminals, and tighten the screws.

Insert the crimping terminals of the AC power cable into the retaining holes of the connection terminals, and tighten the screws with the Phillips-head screwdriver.

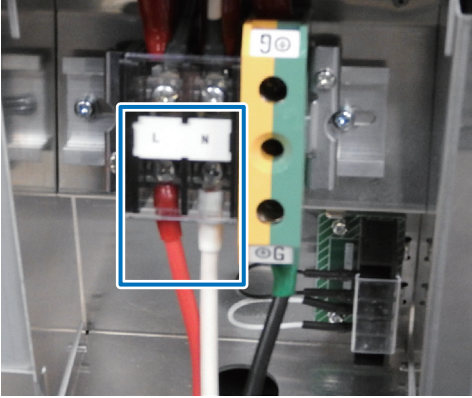

#### WARNING

Securely screw the AC power cable to the connection terminals. Also, after tightening the screws, make sure that all the power cable lines are securely screwed. A failure to do this could result in an accident causing death, injury, etc.

### 5. Put the terminal cover on the power supply terminals.

Follow the reverse procedure to removal of the terminal cover.

### 6. Insert the grounding cable into the grounding terminal, and screw it.

Insert the crimping terminal of the grounding cable into the retaining hole of the connection terminal, and tighten the screw with the Phillips-head screwdriver.

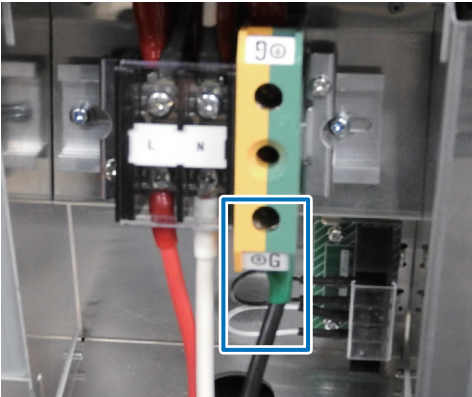

#### WARNING

Securely screw the grounding cable to the connection terminal. Also, after tightening the screw, make sure that the screw is securely tightened. A failure to do this could result in an accident causing death, injury, etc.

## 1. Before Setting Up Your Projector

7. Remove the fixing screws (at two points), eject the fixing bracket in the direction of the arrow, and pull out the power connector.

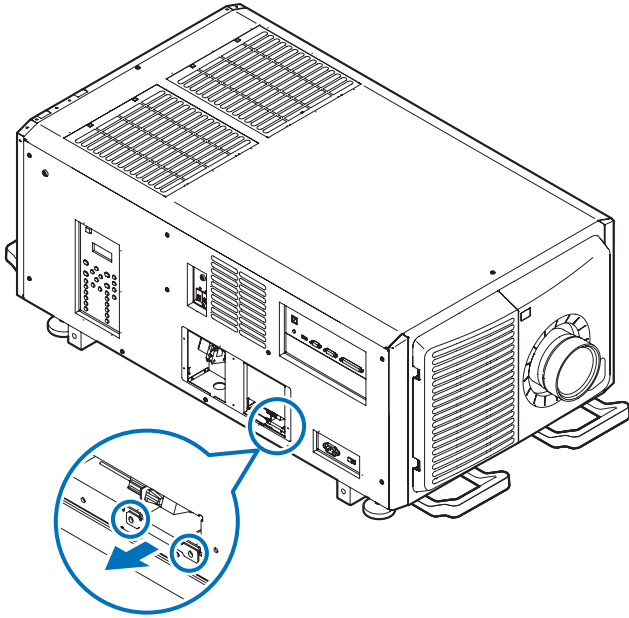

8. Configure the power supply for C1 connection.  
For C1 connection, connect the inner-side connector.

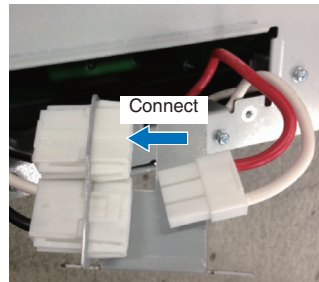
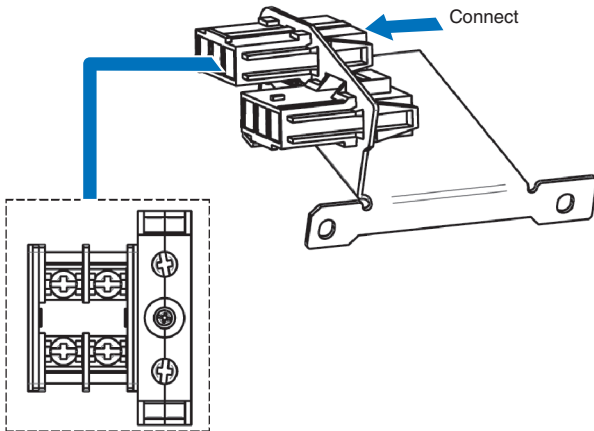

9. Return the power connector and the fixing bracket to their original position, and fix the fixing screws (at two points).
10. Fix the plate inlet with the fixing screws (at six points).  
In Europe, fix the supplied  $\varnothing 35$  plate inlet.

### 1-8-3. Procedure for connecting the power cable (C2 connection)

#### Preparation:

Phillips-head screwdriver (No. 2), service key (projector accessory)

#### WARNING

Before connecting the power cable, make sure that the AC power supply is disconnected. Otherwise a fire or electric shock may occur.

1. Follow steps to in “1-8-2. Procedure for connecting the power cable (C1 connection)” (page 31).

2. Configure the power supply for C2 connection.

For C2 connection, connect the outer-side connector.

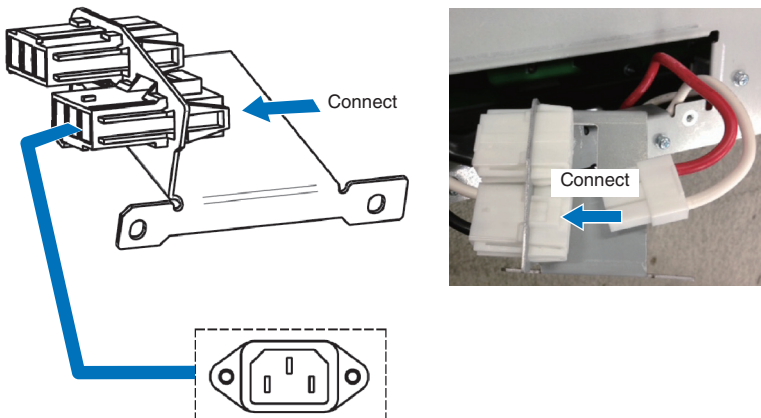

3. Return the power connector and the fixing bracket to their original position, and fix the fixing screws (at two points).

4. Fix the plate inlet with the fixing screws (at six points).

## 1. Before Setting Up Your Projector

### 5. Connect the AC power supply cable.

(1) Connect the AC power supply cable.

Connect the AC power supply cable to the projector.

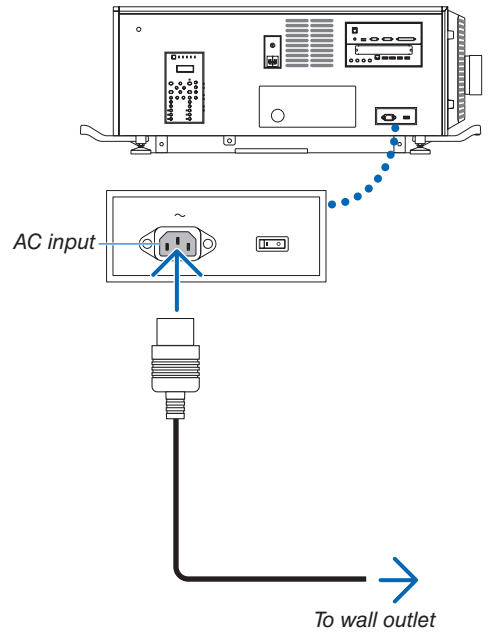

(2) Connect the power plug to the electrical outlet.

This completes the connection of the AC power supply cable.

### Attaching the power cable stopper

To prevent the power cable from accidentally removing from the AC IN of the projector, attach the supplied power cable stopper to clamp the power cable.



#### CAUTION

- To prevent the power cable from coming loose, make sure that all the prongs of the power cable are fully inserted into the AC IN terminal of the projector before using the power cable stopper to fix the power cable. A loose contact of the power cable may cause a fire or electric shock.
- Do not bundle the power cable. Doing this could cause heat or a fire.

#### NOTE

- Do not clamp the power cable with other cables. Doing so can generate noise, which can affect adversely the signal cable.
- Be careful not to insert the band inversely. Once the band is attached, it cannot be removed from the slot.

- 1. Set the clamber band to the power cable side, and insert the end of band of the power cable stopper into the slot next to the AC IN on the terminal panel.**

Attach the power cable stopper to the other side in the same way.

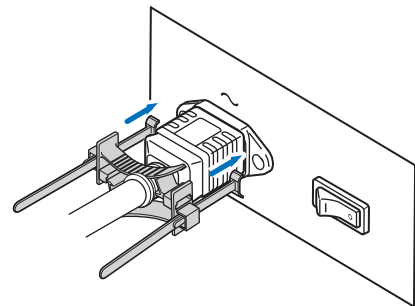

- 2. Pass each band through the slits in the power cable stopper.**

Pass the bands through them so that the power cable will be sandwiched from above and below.

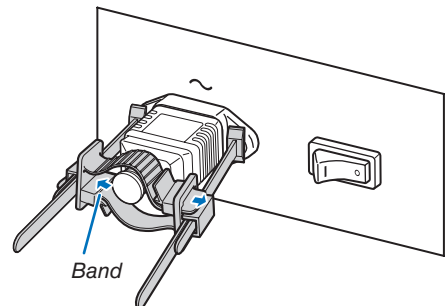

- 3. Slide the clamber to the hilt of the power cable.**

Pulling the knob in the arrow direction allows you to adjust the clamber position.

Once the clamber position is adjusted, release the knob to lock the clamber.

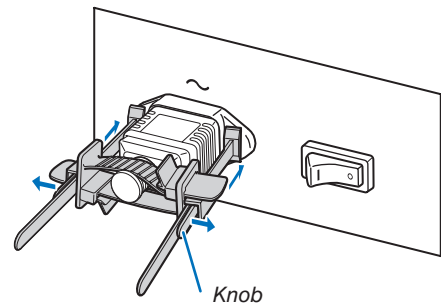

## 1. Before Setting Up Your Projector

### 4. Pull the band to hold the power cable.

*Pulling the knob in the arrow direction allows you to adjust the band position.*

*Pull the top and bottom bands by keeping their balance.*

*Once the band position is adjusted, release the knob to lock.*

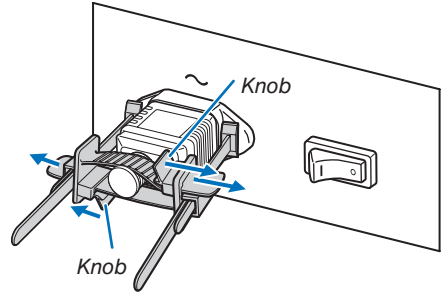

This completes the attachment of the power cable stopper.

### Removing the power cable from the power cable stopper

#### 1. Pull the knob of the clammer and loosen the band.

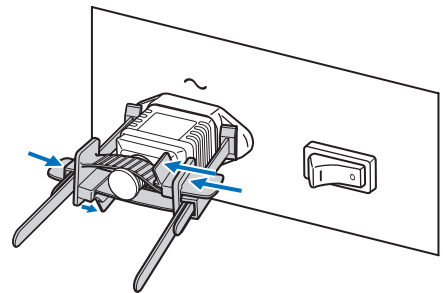

#### 2. Pull the knob and slide the clammer away from the power plug.

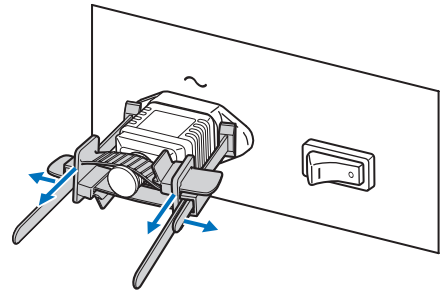

### CAUTION

- The projector may become hot temporarily when the power is turned off or if the AC power is disconnected while the projector is projecting. Take care when handling the projector.

### 1-9. Anschließen des Netzkabels (Deutsch)

Schließen Sie das Netzkabel des Projektors an. Das Netzkabel ist nicht abziehbar sondern fest mit dem Gerät verbunden. Lassen Sie die Installation einer Netzstromversorgung unbedingt nur von professionellen Elektrikern durchführen.

#### WARNUNG

Lesen Sie diesen Abschnitt sorgfältig durch, bevor Sie die Kabel anschließen, und befolgen Sie beim Anschließen der Kabel die entsprechenden Anweisungen. Durch unsachgemäße Handhabung kann es infolge von Bränden oder elektrischen Schlägen zu tödlichen, schweren oder anderen Verletzungen kommen.

#### ACHTUNG

- Vergewissern Sie sich, dass das Gerät von der Stromversorgung getrennt ist, bevor Sie das Netzkabel anschließen.
- Befolgen Sie auf jeden Fall die Anweisungen in diesem Abschnitt.
- Beauftragen Sie einen Fachmann mit der Installation die Stromzufuhr von der Stromversorgungsanlage des Gebäudes zum Aufstellort des Projektors.
- Erden Sie das Gerät, um die Sicherheit zu gewährleisten. Um elektrische Schläge zu vermeiden beauftragen Sie einen Fachmann mit der Erdung und den damit verbundenen Arbeiten. Stellen Sie sicher, dass das Gerät geerdet ist, bevor Sie Strom zuführen.

#### 1-9-1. Technische Daten zum Netzanschluss

Die Netzkabel können auf zweierlei Weise angeschlossen werden: zum einen über Anschluss C1 und zum anderen über Anschluss C2.

##### • Anschluss C1

Die Stromversorgung zu den Netzteilen des Projektors und der Lichtquelle wird über ein einzelnes Kabel zugeführt.

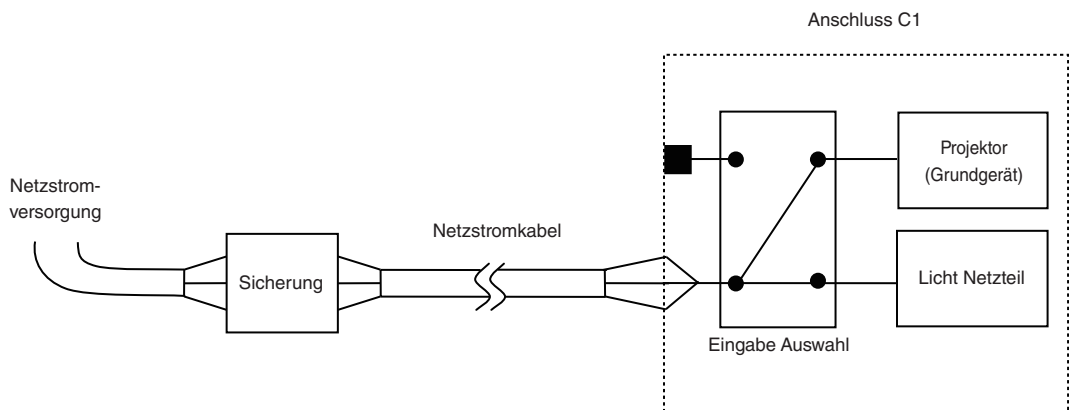



### • Anschluss C2

Die Stromversorgung zu den Netzteilen des Projektors und der Lichtquelle wird über getrennte Kabel zugeführt.

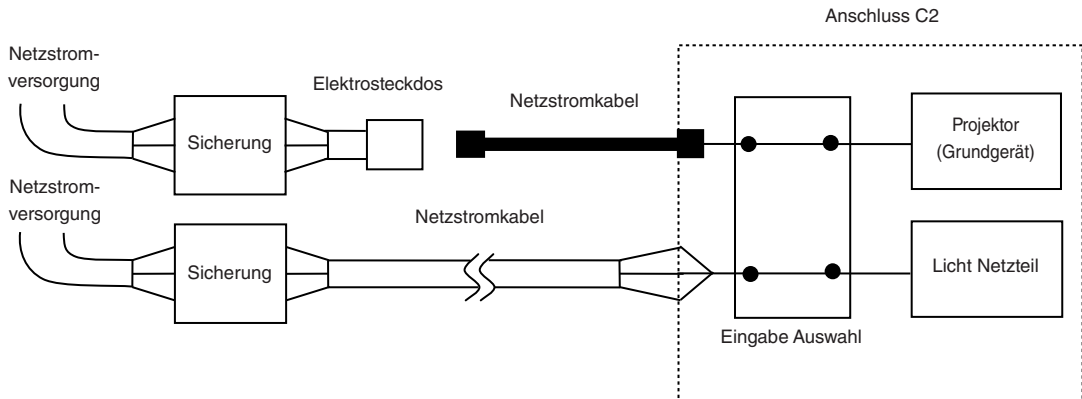

### Wechselstromversorgung

Betreiben Sie den Projektor nur mit den unten angegebenen Netzspannungen.

Bei Verwendung von Anschluss C1

- 200 – 240 V AC, einphasig, 50/60 Hz

Bei Verwendung von Anschluss C2

- 200 – 240 V AC, einphasig, 50/60 Hz (Stromversorgung des Projektors)
- 200 – 240 V AC, einphasig, 50/60 Hz (Stromversorgung der Lichtquelle)

### Sicherungen

Stellen Sie beim Anschließen der Stromversorgungsanlage des Gebäudes an den Projektor sicher, dass dies über eine Sicherung erfolgt. Der maximale Kennwert der Sicherung muss den folgenden Angaben entsprechen.

Bei Verwendung von Anschluss C1

- Stromversorgung des Projektors + Stromversorgung der Lichtquelle  
200V-240 V AC: Eingangsstrom 40A, Einschaltstrom 150A oder höher @10msec

Bei Verwendung von Anschluss C2

- Stromversorgung des Projektors  
200V-240 V AC: Eingangsstrom 10A, Einschaltstrom 60A oder höher @10msec
- Stromversorgung der Lichtquelle  
200V-240 V AC: Eingangsstrom 40A, Einschaltstrom 150A oder höher @10msec

### Eingabe Auswahl

Die Netzanschluss Methode wird durch die Schaltung der Eingabe Auswahl festgelegt. Die Konfigurationsmöglichkeiten sind im Folgenden aufgeführt.

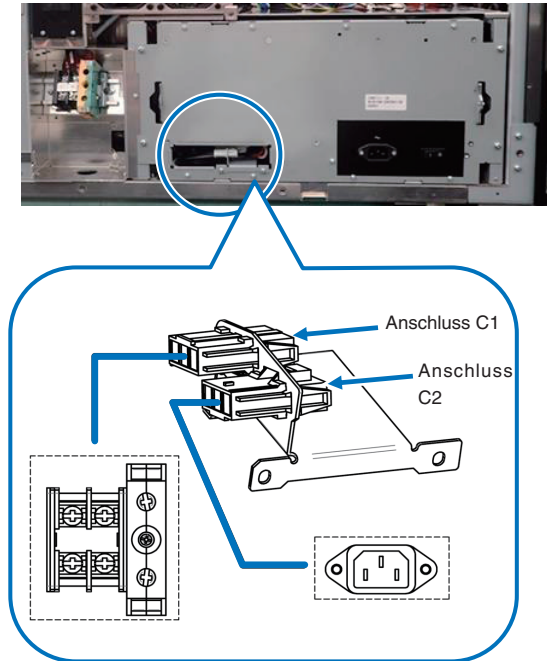

### Netz Kabel

- Verwenden Sie als Netzkabel ein Kabel mit einer Kabelader aus Kupfer und einem Leiterquerschnitt, der den Vorgaben des jeweiligen Landes entspricht (siehe folgende Abbildung).
- Verwenden Sie eine runde lötfreie Anschlussklemme mit dem UL Listing-Prüfzeichen für den an der Haupteinheit angeschlossenen Kabelabschnitt. Verwenden Sie darüber hinaus bei der Klemmung dieser Anschlussklemme ein Werkzeug mit dem UL Listing-Prüfzeichen.

### Kompatible Kabel und lötfreie Anschlussklemmen

Die technischen Daten für die Anschlussklemmen zum Befestigen der Netzkabel sind im Folgenden aufgeführt.

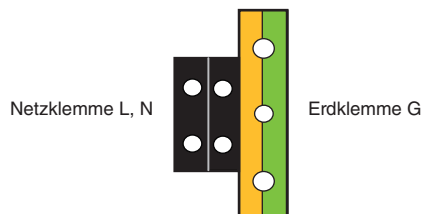

Die Größe der zu verwendenden lötfreien Anschlussklemme und das Anzugsmoment der Schrauben hängen von der Art des Klemmenblocks ab. Verwenden Sie das Kabel und die lötfreie Anschlussklemme, die jeweils für den entsprechenden Klemmenblock geeignet sind (siehe folgende Tabelle). In dieser Tabelle sind die Modellnamen der empfohlenen lötfreien Anschlussklemmen angegeben. Verwenden Sie die angegebenen oder gleichwertige Bauteile. Wenn Sie die empfohlenen lötfreien Anschlussklemmen nicht verwenden können, stellen Sie sicher, dass Sie Anschlussklemmen verwenden, deren Abmessungen den Angaben in der folgenden Tabelle entsprechen.

### WARNUNG

- Das Netzteil verarbeitet hohe elektrische Ströme. Verwenden Sie zur Gewährleistung der Sicherheit Kabeladern entsprechend den in der folgenden Tabelle aufgeführten Vorgaben, und befestigen Sie die Anschlussklemmen am angegebenen Klemmenblock.
- Verwenden Sie immer lötfreie Anschlussklemmen, deren Abmessungen den Angaben in der folgenden Abbildung entsprechen.
- Die Verwendung von Bauteilen mit abweichenden Abmessungen birgt die Gefahr eines Kurzschlusses des Netzteils aufgrund von Hitzeentwicklung und Schmelzen des Klemmenblocks, da der Klemmenblock für die Stromversorgung der Lichtquelle nicht ordnungsgemäß angebracht werden kann.

### • Netzklemme L, N (Schwarz)

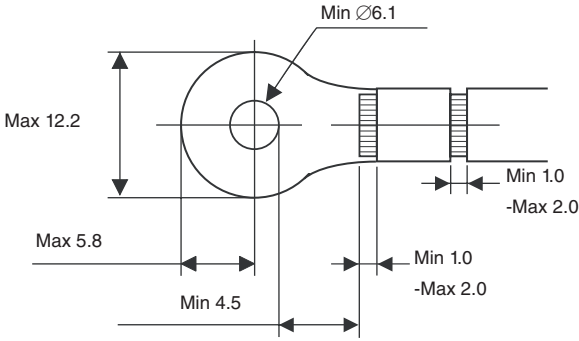
	JIS	IEC/EN	UL	CSA
Leiterquerschnitt kompatibler Kabel (bei Verwendung lötfreier Anschlussklemmen)	14 mm <sup>2</sup>	14 mm <sup>2</sup>	AWG6 oder AWG8	AWG6 oder AWG8
Abmessungen lötfreier Anschlussklemmen	M5 x 10			
Anzugsmoment	2,0 bis 2,5 N·m			
Abmessungen lötfreier Anschlussklemmen	 <p>Unit: mm</p>			
Empfohlene Modelle für lötfreie Anschlussklemmen (J.S.T-Teile)	Modell R8-5		Bei AWG6: Modell R14-5 Bei AWG8: Modell R8-5	

J.S.T: J.S.T. Manufacturing Co. Ltd.

## 1. Before Setting Up Your Projector

### • Erdungsklemme G (Grün/Gelb)

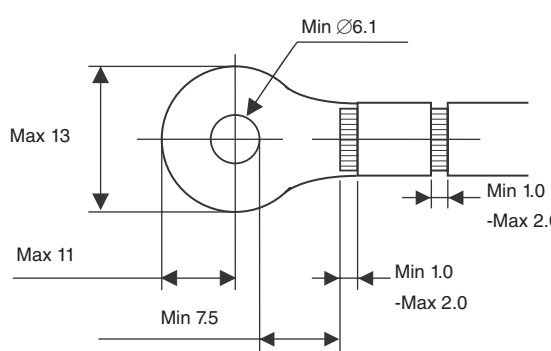
	JIS	IEC/EN	UL	CSA
Leiterquerschnitt kompatibler Kabel (bei Verwendung lötfreier Anschlussklemmen)	14 mm <sup>2</sup>	14 mm <sup>2</sup>	AWG6 bis AWG8	AWG6 oder AWG8
Abmessungen lötfreier Anschlussklemmen	M6 x 15			
Anzugsmoment	3,5 bis 5,0 N·m			
Abmessungen lötfreier Anschlussklemmen	 <p>Unit: mm</p>			
Empfohlene Modelle für lötfreie Anschlussklemmen (J.S.T-Teile)	Modell 8-8NS		Bei AWG6: Modell R14-6 Bei AWG8: Modell 8-8NS	

J.S.T: J.S.T. Manufacturing Co. Ltd.

### Anschließen des Kabels

Schließen Sie zum Befestigen des Netzkabels am Klemmenblock die Drähte entsprechend den folgenden Anweisungen an, sodass sich die einzelnen Drähte nicht direkt berühren können.

- 1. Ziehen Sie die Kabelmanschetten der Netzkabel von den Anschlussklemmen zurück, um sicherzustellen, dass diese nicht von der Schraube der Anschlussklemme eingeklemmt werden.**

Ziehen Sie die Kabelmanschette von der Anschlussklemme zurück, bevor Sie die Schraube anziehen, damit die Kabelmanschette nicht eingeklemmt wird.

- 2. Schieben Sie die Manschetten nach dem Anziehen der Schraube wieder an ihre richtige Position.**

Ziehen Sie die Befestigungsschraube mit dem angegebenen Drehmoment an.

Verwenden Sie Kabelmanschetten und fixieren Sie das Isolationsmaterial, damit sich die Anschlussklemmen nicht berühren. Wenn die Kabel ohne Kabelmanschetten an der Netzklemme befestigt werden, besteht die Gefahr, dass sich die Anschlussklemmen wie in der Abbildung rechts berühren.

Manschetten

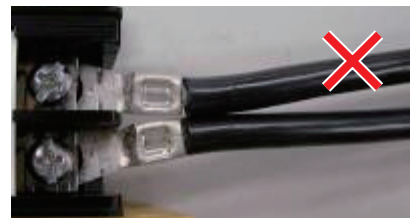
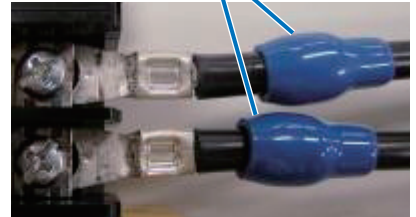

## 1. Before Setting Up Your Projector

Achten Sie beim Anschließen der Kabel an die Masseanschlussklemme darauf, dass keine anderen Teile als der Quetschkabelschuh (z. B. Kabeladern und Verschraubungen) in der Klemmenbefestigung eingeklemmt werden.

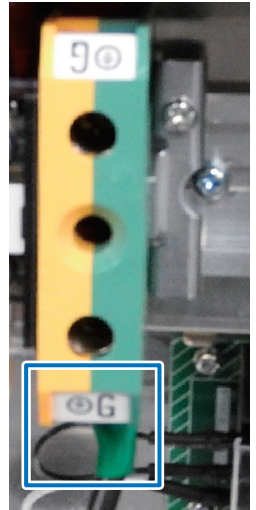

Richtig befestigt.

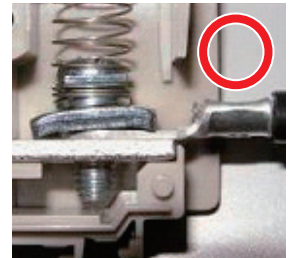

Kabeldraht ist verkantet, da eine lötfreie Anschlussklemme mit Abmessungen verwendet wurde, die nicht den Vorgaben entsprechen.

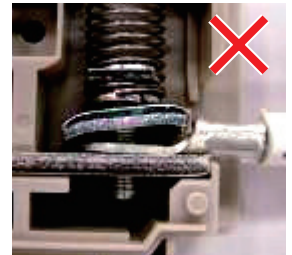

### 1-9-2. Anschluss des Stromkabels (Anschluss C1)

Vorbereitung: Kreuzschraubenzieher (Nr. 2), Serviceschlüssel (Projektorzubehör)

#### **WARNUNG**

- Stellen Sie sicher, dass die Stromversorgung unterbrochen ist, bevor Sie das Stromkabel anschließen. Es besteht Brand- und Stromschlaggefahr.
- Es entsteht viel Kriechstrom. Stellen Sie unbedingt sicher, die Stromversorgung nur anzuschließen, nachdem die Erdung angeschlossen ist.

#### 1. Entfernen Sie die Platte Inlet.

Lösen Sie die sechs Schrauben und entfernen Sie die Inlet-Platte.

EU-Region: Tauschen Sie die Inlet-Platte mit der als Zubehör beigefügten 35mm-Inlet-Platte aus.

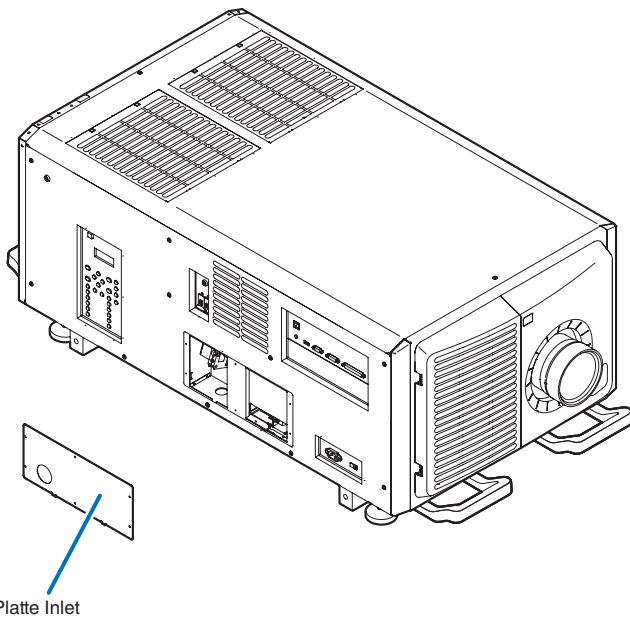

#### 2. Vergewissern Sie sich, dass das Stromkabel durch die Kabelöffnung passieren kann, und ziehen Sie das Stromkabel durch die Kabelöffnung der Platte Inlet.

Wenn Sie die beigefügte 35mm-Platte Inlet benutzen, sichern Sie das Stromkabel mit einem handelsüblichen Kabelfixierer in der Kabelöffnung.

Kabelfixierer

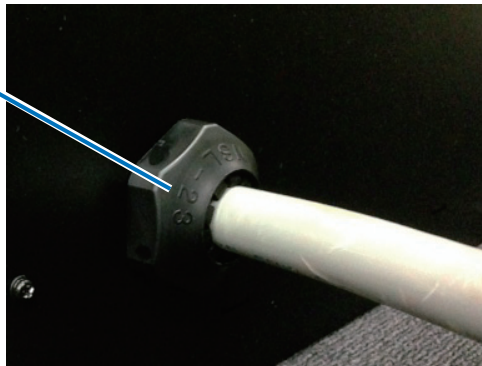

### 3. Entfernen Sie den Deckel der Strombuchse.

Ziehen Sie dazu den Deckel zu sich hin und heben Sie ihn nach oben.

### 4. Stecken Sie die L-Leitung und N-Leitung des Stromkabels in die Anschlussbuchse und schrauben Sie sie fest.

Stecken Sie den Crimpanschluss des Stromkabels in die Öffnung der Anschlussbuchse und schließen Sie die Schrauben mit einem Kreuzschraubenzieher.

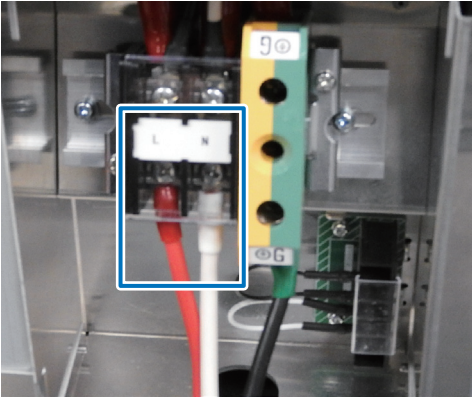

#### **WARNUNG**

Verschrauben Sie das Stromkabel gut in der Anschlussbuchse. Vergewissern Sie sich nach dem Schließen der Schrauben, dass alle Stromkabel gut verschraubt sind. Wenn die Schrauben nicht richtig geschlossen sind, können Tod und schwere Verletzungen die Folge sein.

### 5. Befestigen Sie den Deckel der Strombuchse.

Gehen Sie dabei in umgekehrter Reihenfolge zum Entfernen vor.

### 6. Stecken Sie das Erdungskabel in die Anschlussbuchse und schrauben Sie es fest.

Stecken Sie den Crimpanschluss des Erdungskabels in die Öffnung der Anschlussbuchse, und schließen Sie die Schrauben mit einem Kreuzschraubenzieher.

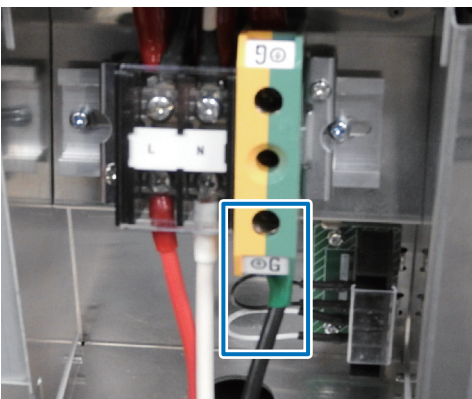

#### **WARNUNG**

Verschrauben Sie das Erdungskabel gut in der Anschlussbuchse. Vergewissern Sie sich nach dem Schließen der Schrauben, dass das Erdungskabel gut verschraubt ist. Wenn die Schrauben nicht richtig geschlossen sind, können Tod und schwere Verletzungen die Folge sein.



## 1. Before Setting Up Your Projector

7. Lösen Sie die zwei Fixierschrauben und entfernen Sie das Fixiermetall in Pfeilrichtung, und ziehen Sie den Stromverbinder heraus.

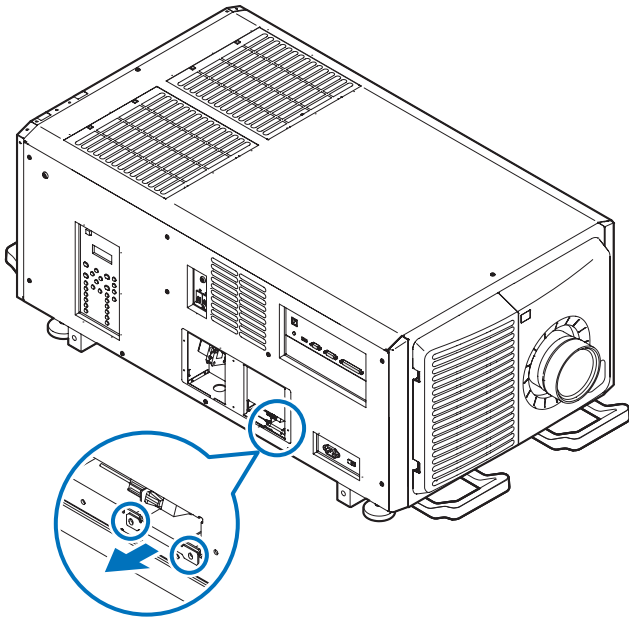

8. Richten Sie die Stromversorgung über Anschluss C1 ein.  
Verbinden Sie Anschluss C1 mit dem hinteren Verbinder.

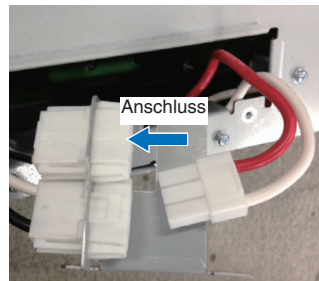
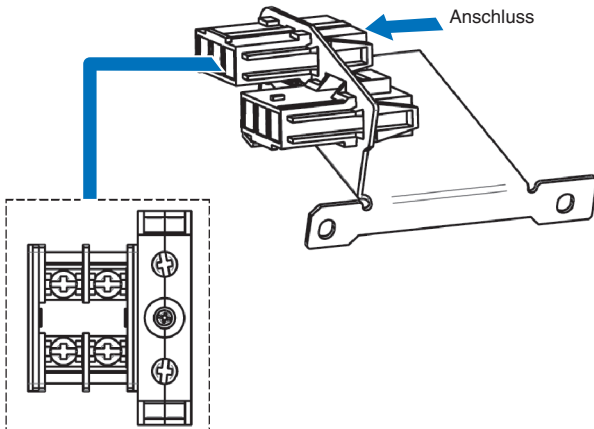

9. Legen Sie den Stromverbinder und das Fixiermetall zurück in ihre ursprüngliche Position, und schließen Sie die zwei Fixierschrauben.

10. Befestigen Sie die Platte Inlet mit sechs Fixierschrauben.

*EU-Region: Befestigen Sie die als Zubehör beigefügte 35mm-Platte Inlet.*

### 1-9-3. Anschluss des Stromkabels (Anschluss C2)

Vorbereitung: Kreuzschraubenzieher (Nr. 2), Serviceschlüssel (Projektorzubehör)

#### **WARNUNG**

Stellen Sie sicher, dass die Stromversorgung unterbrochen ist, bevor Sie das Stromkabel anschließen. Es besteht Brand- und Stromschlaggefahr.

1. Führen Sie die Schritte 1 bis 7 unter „1-9-2. Anschluss des Stromkabels (Anschluss C1)“ (Seite 45) aus.
2. Richten Sie die Stromversorgung über Anschluss C2 ein.  
Verbinden Sie Anschluss C2 mit dem vorderen Verbinder.

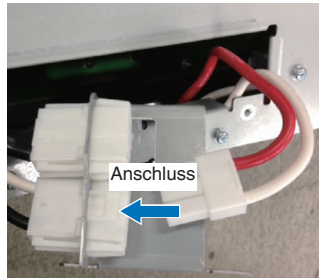
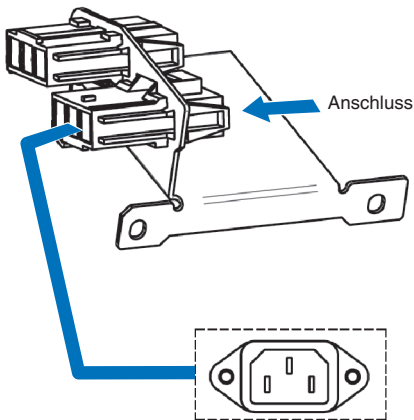

3. Legen Sie den Stromverbinder und das Fixiermetall zurück in ihre ursprüngliche Position, und schließen Sie die zwei Fixierschrauben.
4. Befestigen Sie die Platte Inlet mit sechs Fixierschrauben.

## 1. Before Setting Up Your Projector

### 5. Schließen Sie das Netzkabel an.

(1) Schließen Sie das Netzkabel an.

Schließen Sie das Netzkabel an den Projektor an.

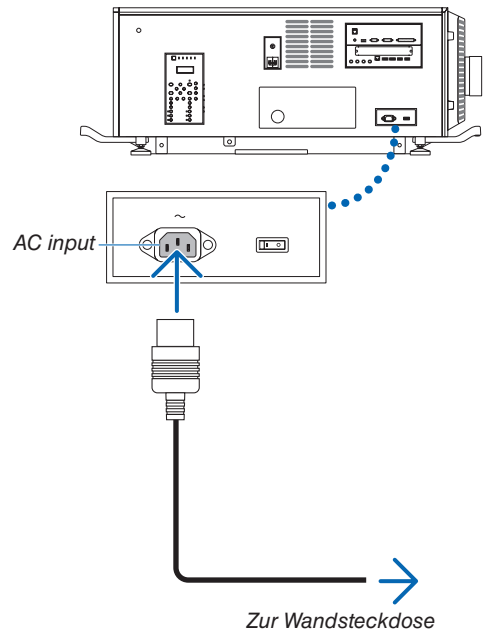

(2) Schließen Sie das Netzkabel an die Netzsteckdose an.

Dadurch ist der Anschluss des Netzkabels abgeschlossen.

### Anbringen des Netzkabelstoppers

Um zu verhindern, dass sich das Netzkabel unbeabsichtigt aus dem Wechselstromeingang des Projektors löst, bringen Sie den im Lieferumfang enthaltenen Netzkabelstopper an, um das Netzkabel zu sichern.

#### ACHTUNG

- Um zu verhindern, dass sich das Netzkabel löst, stellen Sie sicher, dass alle Stifte des Netzkabels vollständig in den Wechselstromeingangsanschluss des Projektors eingesteckt sind, bevor Sie den Netzkabelstopper verwenden, um das Netzkabel zu fixieren. Ein lockerer Kontakt des Netzkabels kann einen Brand oder Stromschlag verursachen.
- Bündeln Sie das Netzkabel nicht. Anderenfalls kann Wärme erzeugt oder ein Brand verursacht werden.

#### HINWEIS

- Klemmen Sie das Netzkabel nicht mit anderen Kabeln zusammen. Dadurch kann elektrisches Rauschen erzeugt werden, welches das Signalkabel stören kann.
- Führen Sie das Band nicht verkehrt herum ein. Wenn das Band einmal angebracht worden ist, kann es nicht mehr aus dem Schlitz entfernt werden.

#### 1. Bringen Sie das Klemmenband auf die Netzkabelseite und führen Sie das Ende des Bands am Netzkabelstopper in den Schlitz neben dem Anschluss AC IN an der Anschlussplatte ein.

Befestigen Sie den Netzkabelstopper in gleicher Weise auf der anderen Seite.

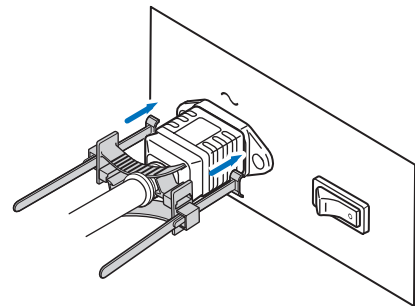

#### 2. Führen Sie jedes Band durch die Schlitz im Netzkabelstopper.

Führen Sie die Bänder so hindurch, dass das Netzkabel von oben und unten gehalten wird.

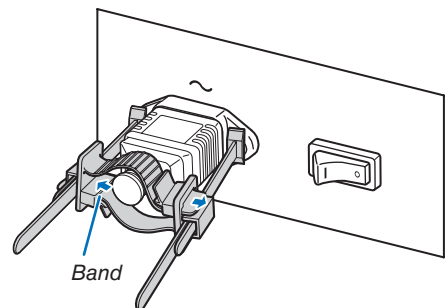

#### 3. Schieben Sie die Klemme bis zum Anschlag des Netzkabels.

Durch Ziehen des Knopfes in Pfeilrichtung können Sie die Klemmenposition justieren.

Sobald die Klemmenposition justiert wurde, lassen Sie den Knopf los, um die Klemme zu sperren.

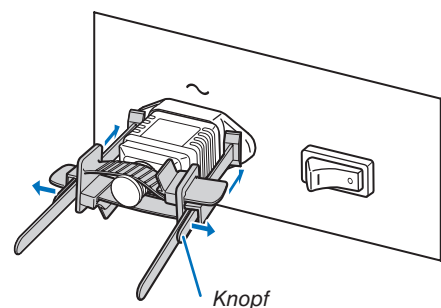

## 1. Before Setting Up Your Projector

### 4. Ziehen Sie das Band zur Befestigung des Netzkabels.

Durch Ziehen des Knopfes in Pfeilrichtung können Sie die Bandposition justieren.

Ziehen Sie das obige und das untere Band gleichmäßig im Wechsel.

Sobald die Bandposition justiert wurde, lassen Sie den Knopf los, um zu sperren.

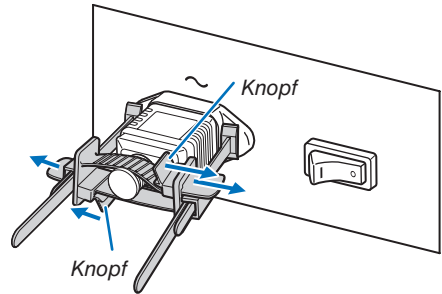

Damit ist die Anbringung des Netzkabelstoppers abgeschlossen.

### Entfernen des Netzkabels aus dem Netzkabelstopper

#### 1. Ziehen Sie den Klemmenknopf, um das Band zu lösen.

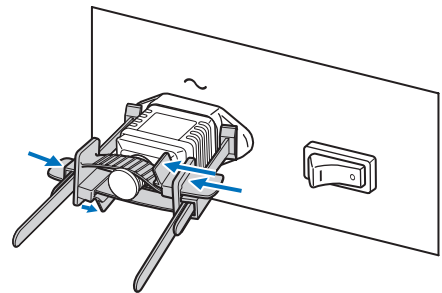

#### 2. Ziehen Sie den Knopf und schieben Sie die Klemme vom Netzstecker fort.

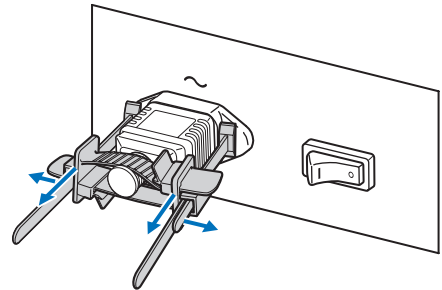

### ACHTUNG

- Der Projektor kann vorübergehend heiß werden, wenn die Stromversorgung ausgeschaltet wird oder wenn der Wechselstrom getrennt wird, während der Projektor projiziert. Seien Sie im Umgang mit dem Projektor vorsichtig.

## 2. Configuring the projector's initial settings

This chapter describes the preparations necessary for using the projector for the first time.

### 2-1. Initial settings flow

#### Step 1

- *Updating the software (this page)*



#### Step 2

- *Installing the LV unit on the projector (→ page 59)*



#### Step 3

- *Attaching the controls/indicator panel display label to the projector (→ page 61)*

---

#### NOTE:

- *Be sure to update the software before mounting the LV unit. Updating the software after mounting the LV unit can cause an update failure.*
- 

### 2-2. Updating the software

#### 2-2-1. Update flow

#### Step 1

- *Installing the DCC on the computer (→ page 53)*



#### Step 2

- *Connecting the computer to the projector and starting up the DCC (→ page 54)*



#### Step 3

- *Updating the projector (→ page 56)*



#### Step 4

- *Exiting the DCC (→ page 58)*

### 2-2-2. Installing the DCC on the computer

#### Overview of DCC

DCC is software for controlling and managing projectors via the network. A maximum of 20 units can be configured and managed from a computer by connecting to the projectors via the network from a computer where DCC is installed.

*TIP:*

- DCC supports “English”, “Chinese (Simplified)”, and “Japanese” for display.

#### Supported devices

Contact your distributor for information about which devices are supported by DCC.

#### Operating environment of DCC

This software can be used with the personal computer that fills the following environments.

Supported OS	Microsoft Windows 7/8/8.1/10 (32-bit or 64-bit) Microsoft Windows Server 2008/2012
LAN environment	Except for supported host names of standard TCP/IP, a fixed IP address is required for most devices that are directly connected to a LAN.
HDD capacity	70 MB <sup>(Note)</sup> or more is required for installation.

(Note): Necessary capacity can vary by updating the DCC.

#### Installing the DCC

This section describes the installation procedure of DCC. Use the same procedure as for installation for version upgrading (installation by overwriting).

#### Preparatory operation:

- Boot up your PC's Windows.
- If you have already started Windows, quit all running application programs.  
If you do not quit all running programs before installing the DCC Software, you risk having unsuccessful installation.

---

#### NOTE

- About the privileges used during software installation and uninstallation
    - For Windows 8/Windows 10  
Perform as a user who has “Administrator” selected as the account type.
  - On Windows 7, if the “User Account Control” window is displayed, click “Allow”. On Windows 8/Windows 10, click “Yes”.
- 

**1. Save the EXE file of the DCC in the local drive of the personal computer.**

**2. Double-click the EXE file that was saved.**

*The installer starts.*

**3. Install the DCC (version upgrading) according to the instruction of the installer.**

*DCC has now been installed (the version has been upgraded).*

#### DCC uninstalling

Uninstall the Software from the menu shown below.

- For Windows 10  
Right-click [Start] → [Control Panel] → [Uninstall a program]
- For Windows 8  
Hold down the [Windows] key and press the [X] key → [Control Panel] → [Uninstall a program]
- For Windows 7  
[Start] → [Control Panel] → [Programs] → [Programs and Features]

## 2. Configuring the projector's initial settings

### 2-2-3. Connecting the computer to the projector and starting up the DCC

1. Connect the computer on which the DCC is installed to the LAN port on the projector using a commercially available LAN cable.

#### NOTE

- The DCC cannot be connected to the HDBaseT port.

2. Set the projector to the standby mode.

Follow the instructions at “4-2. Turning on the Projector” (→ page 70) and set the projector to the standby mode.

3. Start up the DCC.

From the Windows [Start] menu, select [All Programs] → [Projector User Supportware] → [DCC].

The DCC starts up.

#### TIP:

- If the “Language Select” screen appears, select the display language.



- To change the display language, click “Option” - “Language” from the toolbar.

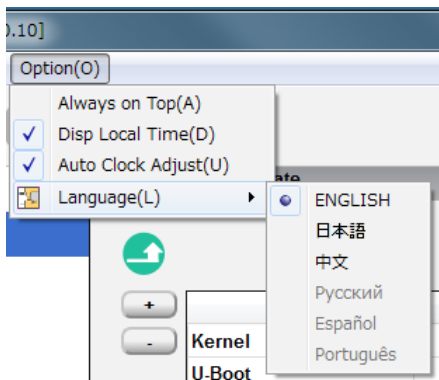

- If a Chinese font or Japanese font is not installed on your PC, then displaying Chinese or Japanese is not supported and the [中文] button or [日本語] button is not displayed.
- DCC supports “English”, “Chinese (Simplified)”, and “Japanese” for display.



## 2. Configuring the projector's initial settings

### 4. Setting a connection destination

When the DCC is activated, the Projector Select screen is displayed. This screen is used to set the IP address or host name of the connection destination device. The connection destination devices that have been connected to are saved in a history, and the connection destination can be selected from this history. This screen can be displayed also by selecting "Select Projector..." from the tool bar.

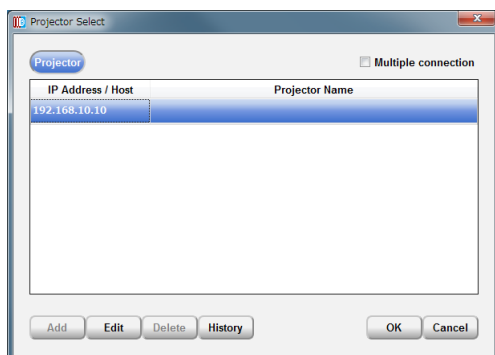

Multiple connection		Allows to set multiple connection destination devices. Without check: Set only 1 connection destination device. With check: Set multiple connection destination devices. When multiple destination devices are set, the currently connected device is located at the top of the connection list.
	IP Address/Host	Enter the network setting of the connection destination device. Select the IP address or the host name and enter the necessary items.  Enter the IP address. <ul style="list-style-type: none"> <li>When entering an address from the connection history, double-click the IP address/Host field, then select the connection history displayed.</li> </ul> Value set at factory shipment: 192.168.10.10
	Projector Name	Displays the host name of the connection destination device.
"Add" button		Adds a connection destination device.
"Edit" button		Sets the connection destination device.
"Delete" button		Deletes the connection destination device.
"History" button		Edits (or deletes) the information history of the connection destination device.

**Check that the IP address is set to the factory default of "192.168.10.10", then click the [OK] button.**

## 2. Configuring the projector's initial settings

### 2-2-4. Updating the projector

#### Preparation:

- Obtain the latest release package and store it in a local drive on your computer.

#### NOTE

- Perform the update by adhering to the following warnings. If you do not adhere to these warnings, there is a risk that the projector will no longer be able to start correctly.
  - Do not turn off the main power to the projector during the update.
  - Do not turn off the PC during the update. Turn power saving functions off.
  - Do not disconnect the LAN cable connecting the PC and projector main unit during the update.

#### 1. On the [MAINTENANCE] → [Update] screen, click the [Update] button.

The Update screen appears.

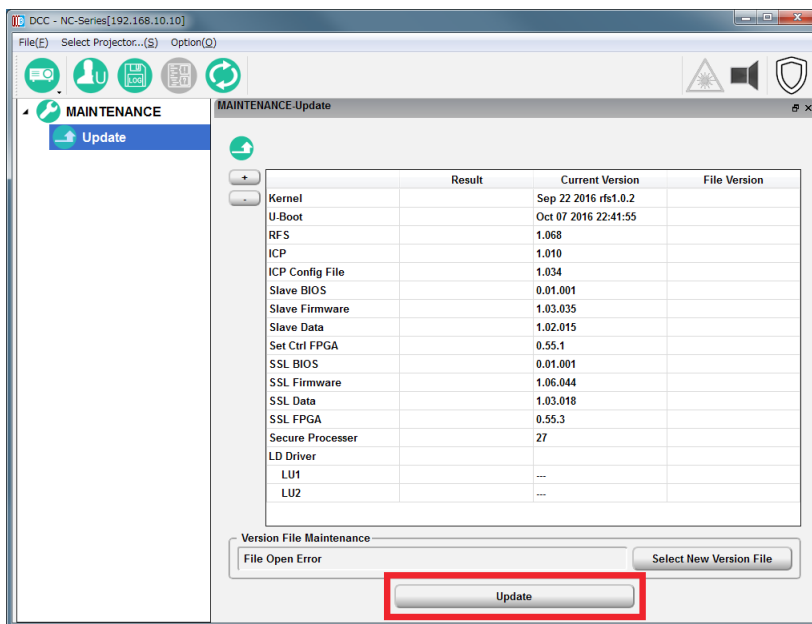

Version File Maintenance	Displays the definition file (*.nversion) that is read by DCC.
"Select New Version File" button	Sets the selected file as the new version file.
Update	Displays the screen for selecting the method for updating.
"Full-Auto" button	Begins Full-Auto Update. When the Full-Auto Update finishes, the button changes to "Update End". Click the "Update End" button to finish the Full-Auto Update (shuts down the projector).
"Semiauto" button	Begins Semiauto Update. When the Semiauto Update finishes, the button changes to "Update End". Click the "Update End" button to finish the Semiauto Update (shuts down the projector).

## 2. Configuring the projector's initial settings

### 2. Click the “Full-Auto” button.

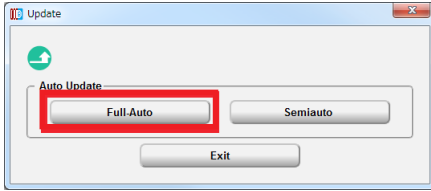

### 3. Select the “nprelease” file stored on the local drive, then click the “Open” button.

A progress bar is displayed and the update begins. The update proceeds automatically.

#### NOTE

- During updating, the projector turns on automatically. After that, the projector automatically returns to the standby state.

### 4. Check the results of the update.

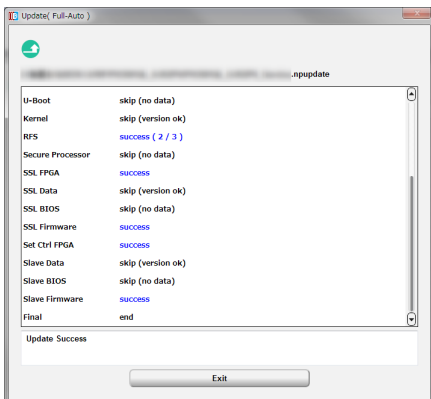

If “Error” is not displayed on the screen bottom of column, the update has completed successfully.

Once the update is completed, a message such as the following appears below the screen.

If the update is successful: Update Success

If the update is unsuccessful: Update has failed

### 5. Once the update is successful, click the “Exit” button.

The All Update screen closes.

### 6. Click the “Update End” button.

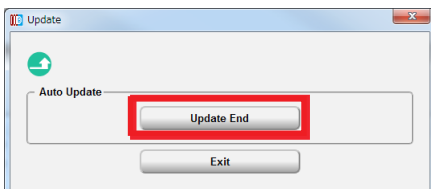

## 2. Configuring the projector's initial settings

### 7. Check that all of the results are "OK".

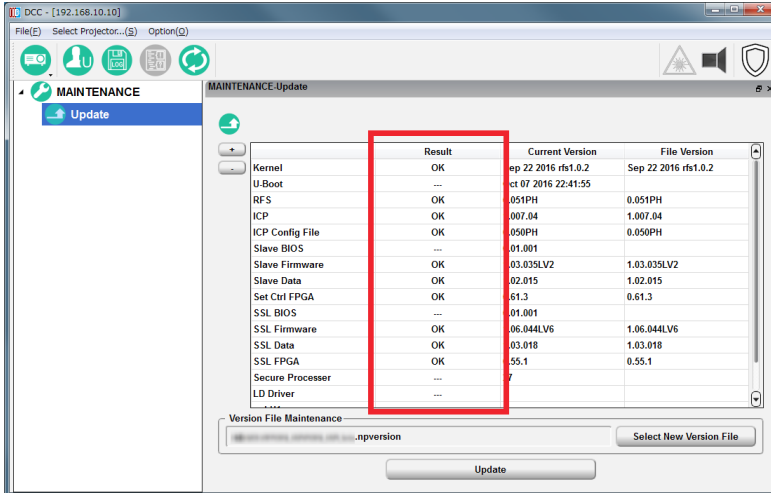

#### **If Different is displayed**

Return to step 1 and execute the update again.

#### NOTE

- When, after having mounted the LV unit, updating the projector for the purpose of version upgrade, instead of the projector's initial settings, set the projector's IP address to a connection destination, and execute from step 1 through step 7. The projector's IP address can be checked on the setting of WIRED LAN from the onscreen menu.
- The update for the purpose of the initial settings must be done before mounting the LV unit.

### 2-2-5. Exiting the DCC

#### 1. Click "File".

The [File] menu will appear.

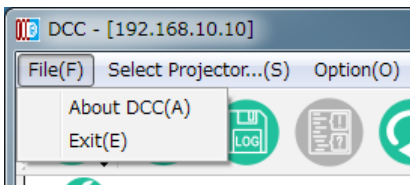

#### 2. Click "Exit".

The DCC will close.

#### 3. Turning off the Projector

Follow the procedure at "4-6 Turning off the Projector" (→ page 85) to turn off the projector's power, then disconnect the AC power.

#### TIP:

- To check the projector's information and log using the DCC, see "7-8.Using the DCC's functions" (→ page 118).

### 2-3. Installing the LV unit

Mount the LV unit on the projector unit.

**NOTE:**

- The projector cannot be used alone. Be sure to mount the LV unit before using the projector.
- Before mounting, be sure to turn off the projector's power, disconnect the AC power and unplug the power cord.

**Preparation:**

- Prepare a Phillips screwdriver.
- Remove the side panel. (→ page 17)

**1. Remove slot blocking panel A.**

- (1) Loosen the blocking panel A screws (2) until they turn freely.  
The screws do not come off.

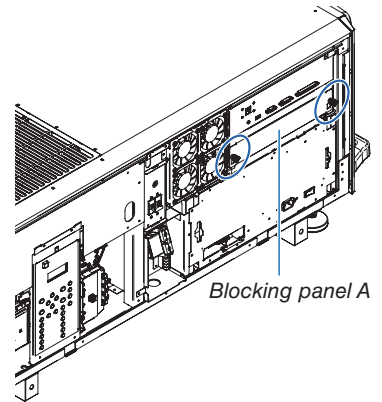

- (2) Remove blocking panel A.

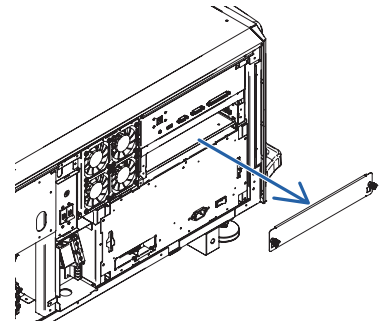

**2. Remove slot blocking panel B.**

- (1) Loosen the blocking panel B screws (3) located inside the slot until they turn freely.  
The screws do not come off.

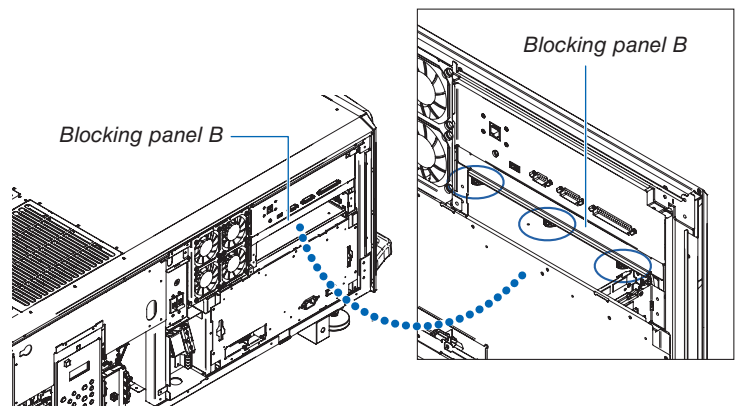

## 2. Configuring the projector's initial settings

(2) Remove blocking panel B.

**NOTE:**

- After removing blocking panels A and B, be sure to store them in a safe place.

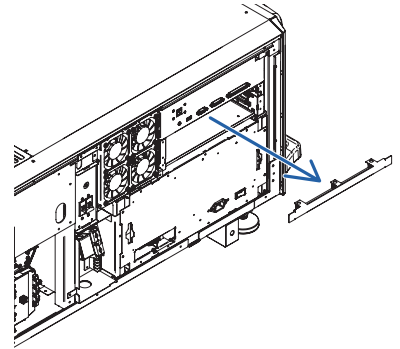

### 3. Mount the LV unit onto the projector.

(1) Insert the LV unit by following the guide on either side of the slot.

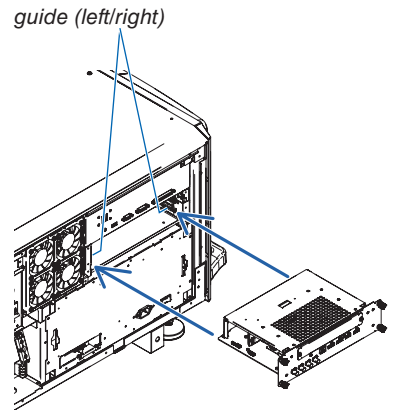

(2) Tighten the screws (4) on the front of the LV unit to fasten.

**NOTE:**

- Set the LV unit's displays in the proper direction, according to the projector. Inserting the LV unit upside down can result in damage
- Tighten the screws securely.

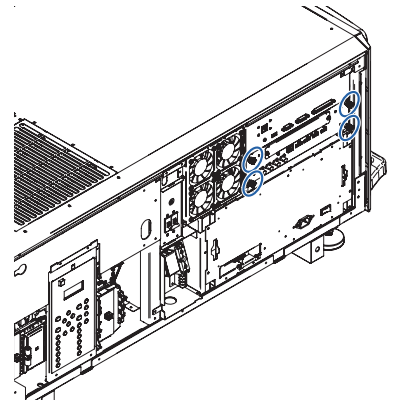

This completes installing of the LV unit.  
Next, attach the controls/indicator panel display label.

### 2-4. Attaching the controls/indicator panel display label

Attach the supplied controls/indicator panel display label to the projector's control panel.

- (1) Peel off the default attached label.
- (2) Peel the label off the backing paper and attach it to the projector's control panel.
  - Line up the corners of the label with the four protrusions.
  - Install carefully, making sure the label does not touch the buttons.

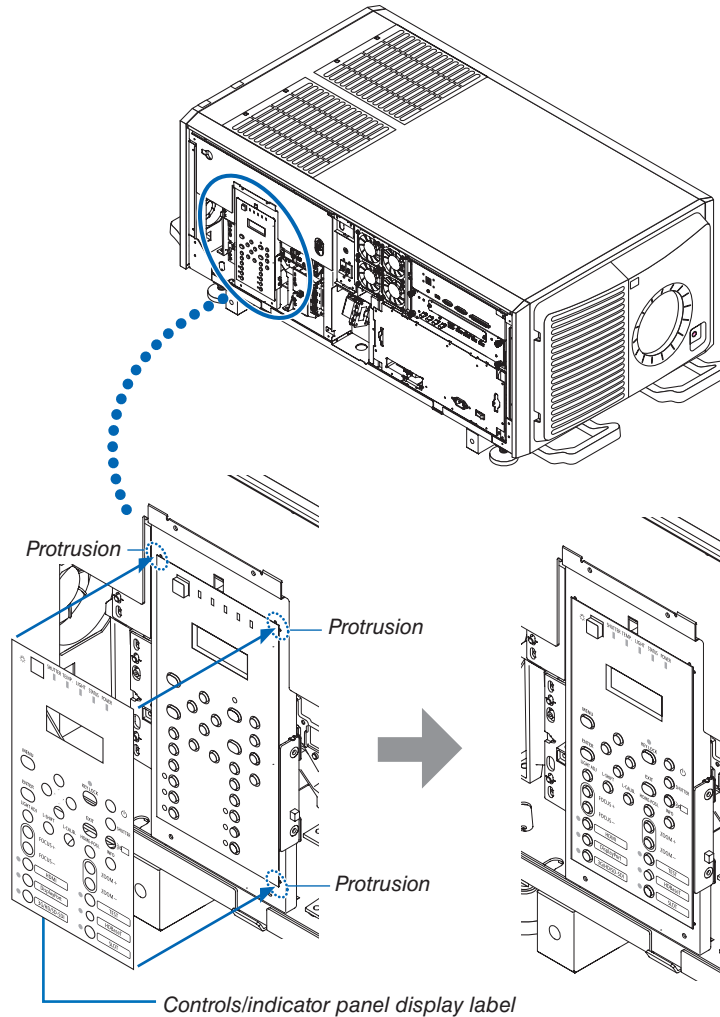

This completes mounting of the controls/indicator panel display label.  
Mount the side panel. (→ page 17)

# 3. Setting Up Your Projector

---

## 3-1. Setup Procedure

Set up the projector according to the procedure below. This chapter describes the installation of procedure until turning on of the power.

### Step 1

- *Installing the projector* (→ [page 63](#))



### Step 2

- *Mounting the Lens Unit* (→ [page 64](#))



### 3-2. Installing the projector

Move the projector to the projection position and install it corresponding to the screen and projection conditions. The projector must be placed square to the screen otherwise keystone distortion may appear on the screen. For setting the projector perpendicular to the screen when viewed from the side, utilizing the level adjusters equipped at each corner of the projector bottom. (→ page 76)

#### Example for adjustment

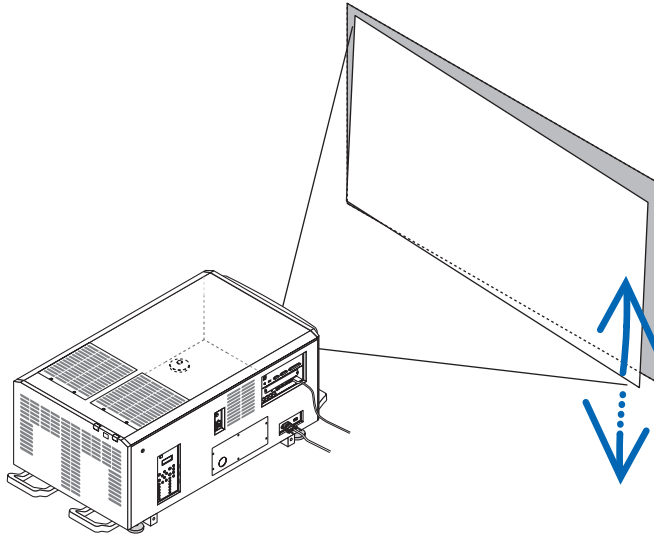

To install as shown below, see “7-7. Special Installation” (→ page 113).

- Installing the Projector on the Ceiling
- Installing using eye bolts
- Installing with free tilting
- Portrait projection (vertical orientation)
- Multi-Screen Projection

### 3-3. Mounting the Lens Unit

The lens units that can be attached to this projector are shown in the following table.

MODEL	Magnifying
L2K-10F1	0.93
L4K-11ZM	1.24–1.73
L4K-15ZM	1.52–2.10
L4K-20ZM	1.98–3.34
L2K-30ZM	2.71–3.92
L2K-43ZM1	3.91–5.52
L2K-55ZM1	5.00–7.80

**NOTE:**

- *The other NEC optional lenses are not available on this model.*
- *The projector and lenses are made of precision parts. Do not subject them to shock or excessive forces.*
- *Remove the lens unit when moving the projector. If not, the lens could be subject to shock while the projector is being moved, damaging the lens and the lens shift mechanism.*
- *When removing or installing the lens unit, return the position of the lens to the center before turning off the power to the projector. If the position of the lens is not returned to center, the front cover will interfere with the lens and the cover cannot be removed or installed.*
- *When installing or removing the lens unit, first confirm that the main power switch to the projector is off, and then disconnect the AC power supply. After the AC power supply has been disconnected, allow the projector to sufficiently cool before starting this work.*
- *Never touch the lens surface while the projector is operating.*
- *Be very careful not to let dirt, grease, etc., on the lens surface and not to scratch the lens surface.*
- *Perform these operations on a flat surface over a piece of cloth, etc., to prevent the lens from getting scratched.*
- *When leaving the lens off the projector for long periods of time, mount Dust-proof cushion on the projector to prevent dust or dirt from getting inside.*

Mounting and adjustment of optional lenses must be performed by a qualified technician.

The lens unit mounting procedure is roughly the same.

- For L2K-30ZM, L2K-43ZM1, and L2K-55ZM1, attach the gearbox cover.
- For the L4K-20ZM, the lens cover's ring must be removed.

At the same time, the image adjustment mechanism by manual besides the focus adjustment is also equipped on the L4K-11ZM, L4K-15ZM and L4K-20ZM.

### 3. Setting Up Your Projector

#### 1. Remove two mounting metals of the lens holder.

Remove four mounting screws and remove two mounting metals.

These four mounting screws and two mounting metals will be used for lens holder mounting.

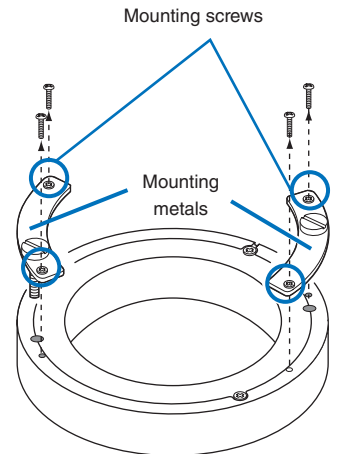

#### 2. Place the lens with the face upward.

Check that the place for putting the lens is flat before the work.

It is recommended to keep the lens cap set so as to protect the lens from any damage.

#### 3. Insert the lens holder from under the lens.

Align the lens holder slits with two lens insertion guides and insert the lens holder.

#### 4. Fix two mounting metals of the lens holder with four mounting screws.

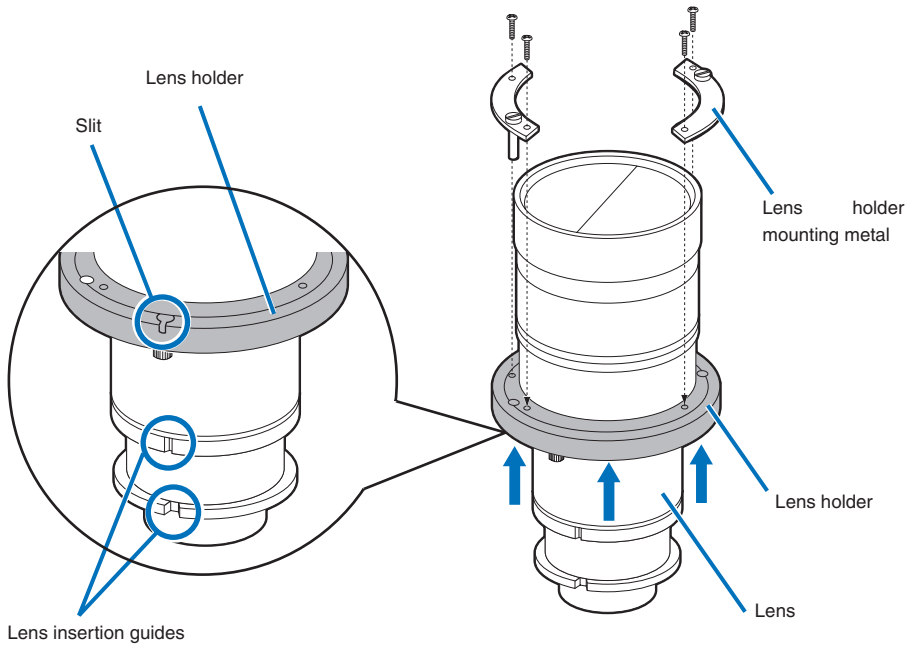

(Applicable lens units: L2K-30ZM, L2K-43ZM1 and L2K-55ZM1)

#### **Attach the gearbox cover.**

Attach the attached gearbox cover with two screws.

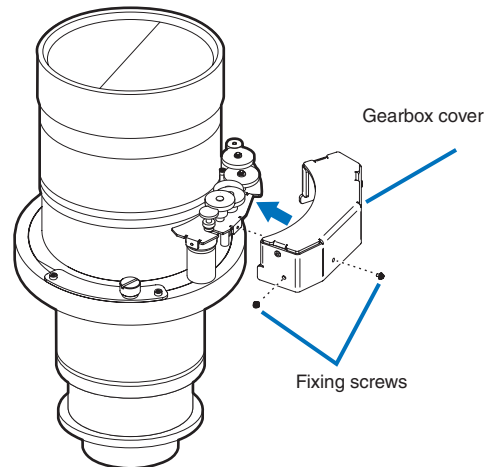

#### **5. Remove the lens cap.**

If the lens has a lens cap, remove the lens cap.

#### **6. Remove the lens cover.**

For removal of the lens cover, Refer to “1-5-1. Removing and Mounting the Lens Cover” (page 15).

When mounting the L4K-20ZM, loosen the screws (4) on the back of the lens cover, then remove the ring.

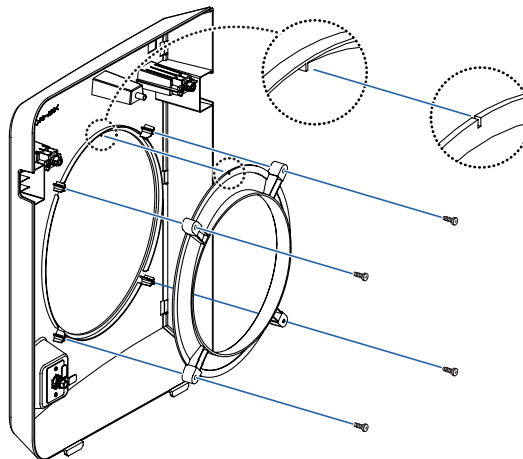

- Be sure to store the ring and screws you have removed in a safe place.
- When replacing the L4K-20ZM with another lens unit, be sure to mount the ring on the lens cover.

#### **Mounting the ring**

1. Line up the protruding part on the back of the lens cover with the notch in the ring (the circle on the diagram).
2. Tighten the screws (4).

### 3. Setting Up Your Projector

- 7. Hold the lens unit with its guide faced upward and insert the lens until it cannot go further.**

*Insert the lens holder into the fixing hole of the lens ring and mount it with rotating it clockwise.*

*Pay attention not to catch the lens control cable here.*

Fixing hole of the lens ring

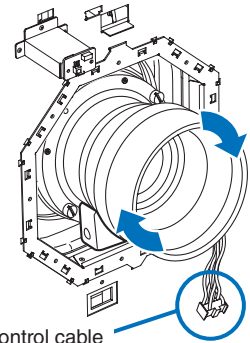
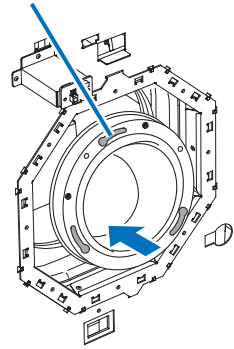

- 8. Tighten the two fixing screws for the lens holder.**

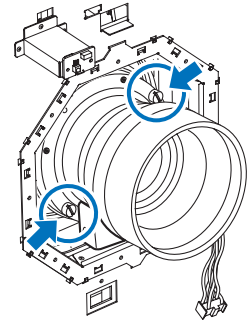

- 9. Connect the control cable.**

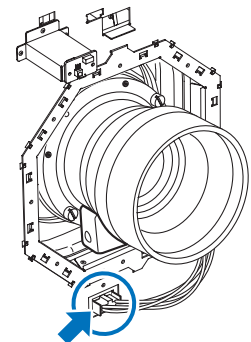

#### 10. Attach the lens cover.

For details on attaching the lens cover, refer to “1-5-1. Removing and Mounting the Lens Cover” (page 15).

This completes the installation of the lens unit. Removal is done in reverse order of installation.

**NOTE:**

- When unplugging the lens control cable at the time of lens unit replacement, be sure to do so by holding both top and bottom sides of the connector. Doing so by holding both left and right sides of the connector may cause the connector at the projector to come off.

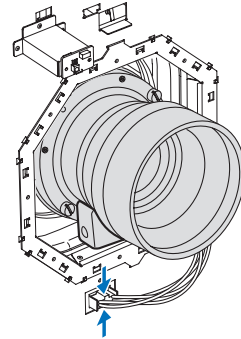

#### Preventing the lens unit from falling

When suspending the projector, from the ceiling or otherwise, use commercially available wire rope and an attachment to secure the lens unit. In this case, allow about 20 mm of flexure of the wire rope for the lens shifting range.

- Recommended wire: Rope diameter 3.0 mm
- Place the wire around the lens unit and the projector's handle, then tighten it with the attachment to fasten it in place.

**NOTE:**

- Too tight wire rope can cause structural failure of the lens shift while too loose wire rope can cause the lens unit to fall off. Be sure to adjust the flexure of the wire rope to allow for 20 mm of flexure and secure it.



# 4. Projector Adjustment and Connecting

---

## 4-1. Flow of Adjustment and Connecting

Perform the adjustment and connection of the projector according to the the following procedure

### Step 1

- **Turning on the Projector** (→ [page 70](#))



### Step 2

- **Selecting the projector orientation** (→ [page 74](#))



### Step 3

- **Adjusting the Picture Size and Position** (→ [page 75](#))

*Display the test pattern to adjust the screen size, screen ratio and focus.*



### Step 4

- **Connecting to Other Equipments** (→ [page 82](#))



### Step 5

- **Turning off the projector** (→ [page 85](#))

This chapter explains the adjustment and connection of the projector with Steps from 1 to 5. The adjustment and connection of the projector is completed by performing all steps in order

### 4-2. Turning on the Projector

Please contact your dealer/distributor to connect the power cable.

#### Preparation:

- Connect the power cable to the projector. (→ page 24)
- Supply AC power to the projector.

---

#### NOTE:

- Turn off the projector power switch and light power switch to the projector when cutting AC power to the projector. Shutting down the AC power while the projector power switch and light power switch is on will damage the projector.
- Turning on and off the projector involves a two-step operation; the “projector power switch and light power switch” and the “POWER button” (POWER ON and OFF on the remote control).

#### Turning power on. (See this page)

1. Turn on the “projector power switch and light power switch” of the projector.

Your projector is set in a standby state.

2. Press the  (POWER) button on the projector cabinet or the POWER ON button on the remote control.

Your projector is turn on.

#### Turning power off. (→ page 85)

1. Press the  (POWER) button on the projector cabinet or the POWER OFF button on the remote control.

The confirmation message will be displayed.

2. Press the  (POWER) button or the POWER OFF button again.

Your projector is set in a standby state.

3. Turn off the “projector power switch and light power switch” of the projector.

Your projector is turned off.

---

1. Remove the lens cap.

2. Insert the administrator key vertically, and turn it to the right.

The administrator key can no longer be removed. The projector will not function unless the administrator key is inserted.

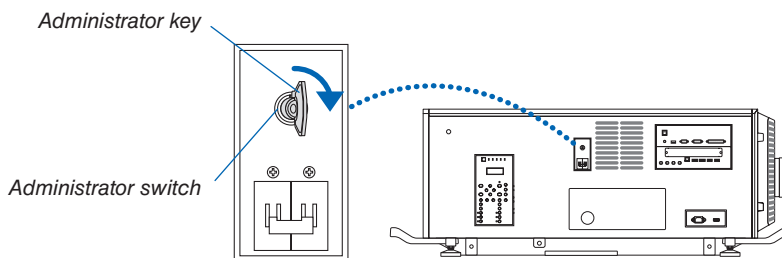



## 4. Projector Adjustment and Connecting

### 3. Turn on the light power switch ([1]) then the projector power switch ([2]) on the side of the projector.

The POWER indicator lights up orange.

- The buzzer sound is released when [NOTIFICATION SETTING] for [BUZZER] is ON.

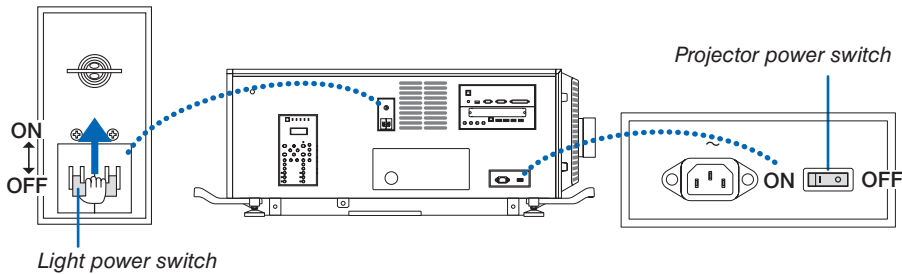

### WARNING

The projector produces a strong light. When turning on the power, make sure no one within projection range is looking at the lens.

### 4. Press the (POWER) button on the projector cabinet or the POWER ON button on the remote control.

The POWER indicator goes from a steady orange light to a steady green light, and the picture is projected on the screen.

- If using the remote control, press the POWER ON button.
- When there is no signal the unit will project a blue screen (factory default menu settings).
- If the picture is blurry, adjust the screen focus. (→ page 79)
- When it is dark press the  (lights) button. The indicator panel backlight and the LED lamp on the right side of the projector will turn on.

#### TIP:

- The lens shutter remains closed even when the power is turned on with the Power On Shutter function.
- Pressing the button will not activate the unit when the KEY LOCK indicator is flashing orange.
- When the message "PROJECTOR IS LOCKED! ENTER YOUR PASSWORD." is displayed, it means that the [SECURITY] feature is turned on.

After you power on your projector, ensure that the computer or video source is turned on.

**NOTE:** The blue screen ([BLUE] background) is displayed when no signal is being input (by factory default menu settings).

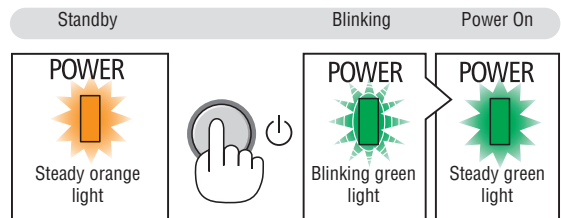
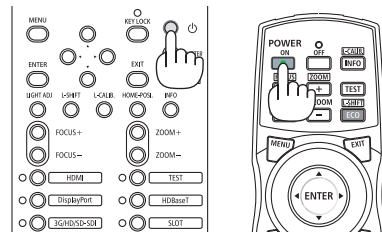

## 4. Projector Adjustment and Connecting

### Performing Lens Calibration

- After installing the lens unit L4K-11ZM/L4K-15ZM/L4K-20ZM (sold separately), press the L-CALIB. button on the projector, or hold down the CTL button on the remote control then press the INFO/L-CALIB. button to carry out [LENS CALIBRATION].

By carrying out [LENS CALIBRATION], the adjustment range of the zoom of the [LENS MEMORY] is calibrated. If you need to install or replace the lens unit, contact your distributor and have them do it for you.

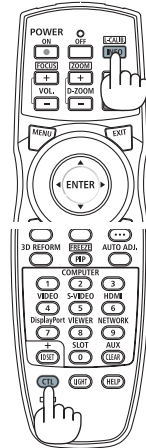
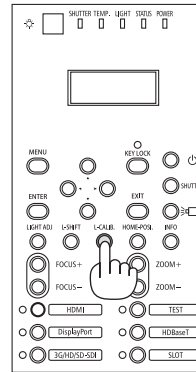

## 4. Projector Adjustment and Connecting

### Note on Startup screen (Menu Language Select screen)

When you first power on the projector, you will get the Startup menu. This menu gives you the opportunity to select one of the 30 menu languages.

To select a menu language, follow these steps:

#### 1. Use the ▲, ▼, ◀ or ▶ button to select one of the 30 languages from the menu.

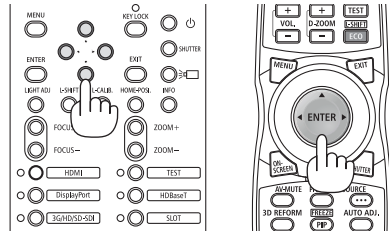

#### 2. Press the ENTER button to execute the selection.

After this has been done, you can proceed to the menu operation.

If you want, you can select the menu language later.

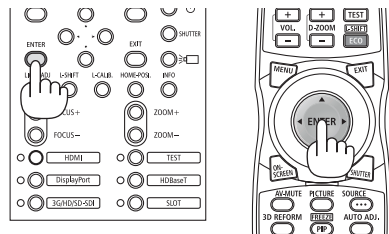

#### NOTE:

- If the message, [PLEASE SET "DATE AND TIME".] is shown, please set the current date and time.
- When the KEY LOCK indicator is flashing, that means [CONTROL PANEL LOCK] has been set and pressing the  button will not cause the unit to power-on. Release [CONTROL PANEL LOCK].
- While the POWER indicator is blinking green in short cycles, the power cannot be turned off by using the power button. (While the POWER indicator is blinking green in long cycles, the [OFF TIMER] is functioned and the power can be turned off.)

### 4-3. Selecting the projector orientation

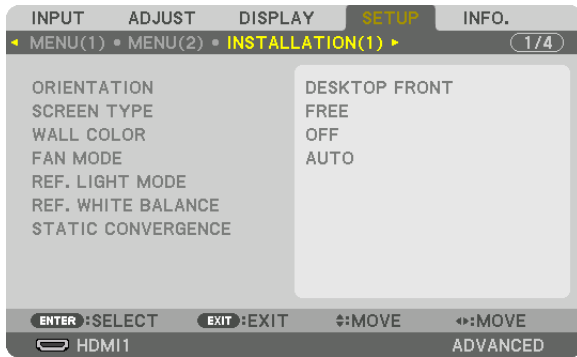

This reorients your image for your type of projection. Select [SETUP] → [INSTALLATION(1)] → [ORIENTATION] in the on-screen menu. The options are: desktop front projection, ceiling rear projection, desktop rear projection, and ceiling front projection.

**NOTE:**

- Please consult the distributor if you require special installation services e.g. when mounting the projector to a ceiling or suspending from the ceiling using eye bolts. Never install the projector on your own. This may result in the projector falling down and causing injury to people.

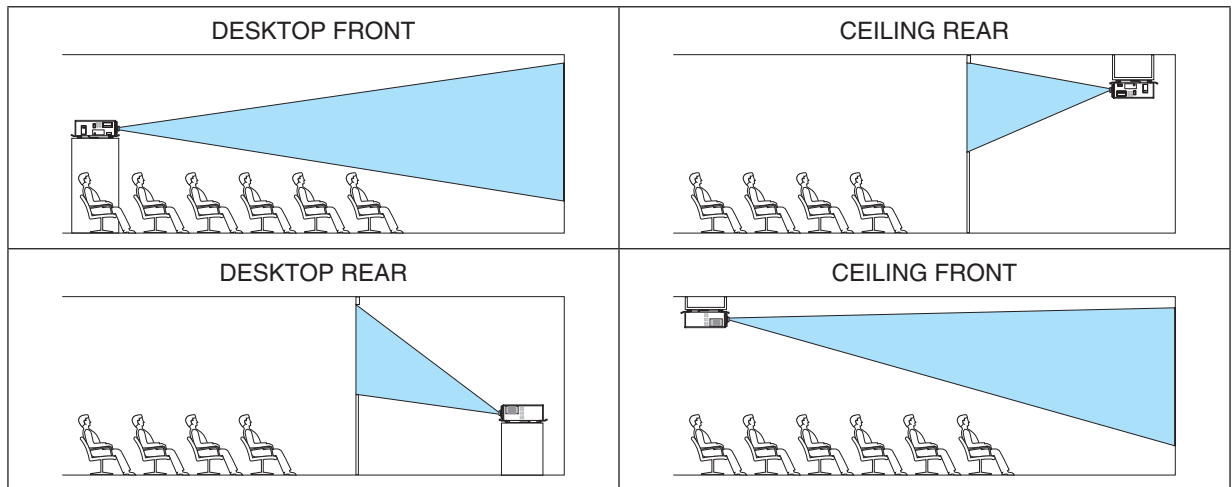

## 4-4. Adjusting the Picture Size and Position

Adjusting the projector's settings  
[Level adjuster]  
(→ page 76)

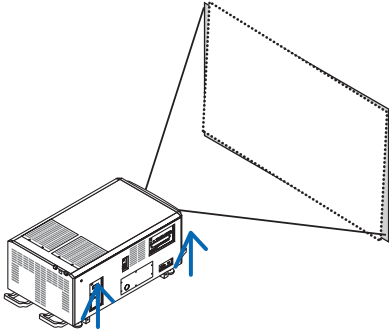

Adjusting the projected image's vertical and horizontal position  
[Lens shift]  
(→ page 77)

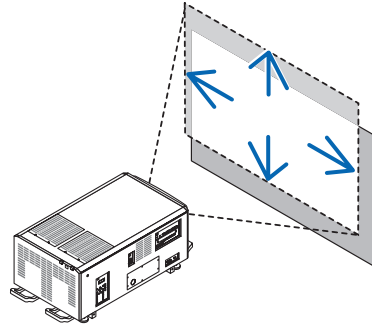

Adjusting the focus  
[Focus]  
(→ page 79)

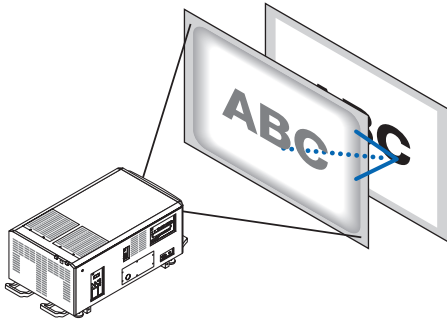

Finely adjusting the size of an image  
[Zoom]  
(→ page 81)

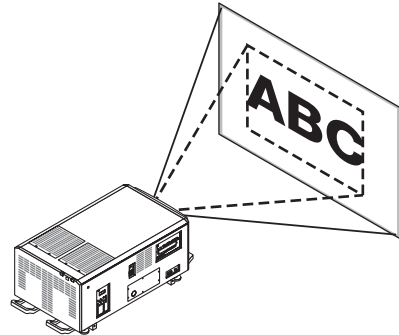

In this chapter drawings and cables are omitted for clarity.

*TIP:*

- Built-in test patterns can be conveniently used for adjusting the picture size and position. A press of the TEST button will display the test pattern. The ◀ or ▶ button can select one test pattern. To close the test pattern, change the source to another.

## 4. Projector Adjustment and Connecting



**CAUTION**

- Perform the adjustment from behind or from the side of the projector. Adjusting from the front could expose your eyes to strong light which could injure them.
- Keep hands away from the lens mounting portion while the lens shift is in operation. Failure to do so could result in hands being pinched by the moving lens.

### 4-4-1. Adjustment of the projector's settings (Level adjusters)

The projector must be placed square to the screen otherwise keystone distortion may appear on the screen. For setting the projector perpendicular to the screen when viewed from the side, utilizing the level adjusters equipped at each corner of the projector bottom. Maximum Adjustable length of the level adjuster is 10 mm/0.39".

#### Example for adjustment

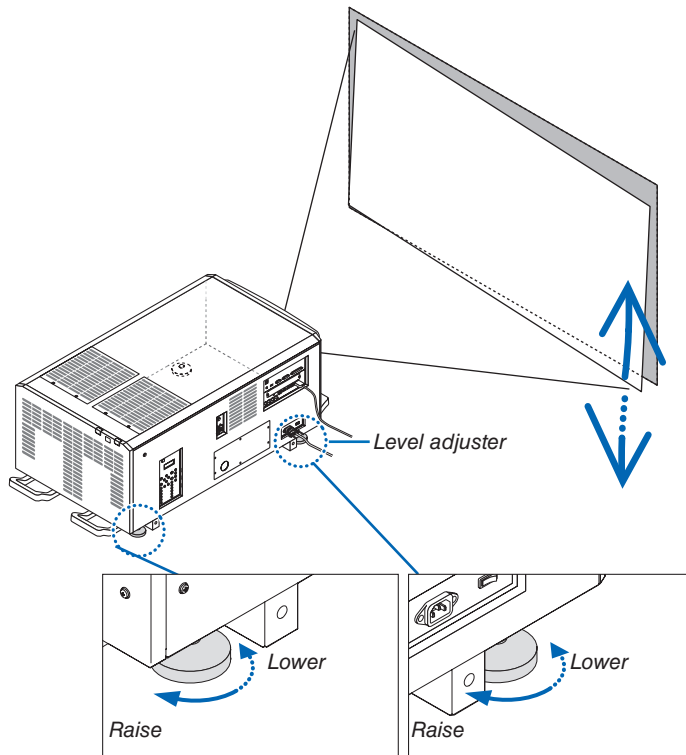

#### NOTE:

- Do not lengthen each of the level adjusters any more than 10 mm/0.39". The force of doing so may cause the level adjuster to come off, resulting in damage to the projector.
- Pay attention to lengthen or shorten two level adjusters at front at the same time. Same for the rear adjusters, otherwise, the weight of the projector is loaded on one level adjuster and it may cause of damage to it.

### 4-4-2. Adjusting the vertical position of a projected image (Lens shift)

**NOTE:**

- Shifting the lens to the maximum in two directions combined will cause the edges of the image to become dark or will cause some shadows.

#### Adjusting with buttons on the cabinet

**1. Press the L-SHIFT button.**

The [LENS SHIFT] screen will be displayed.

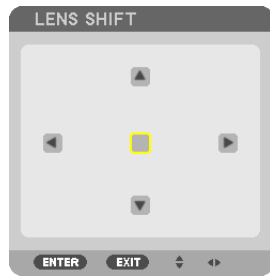

**2. Press the ▼▲◀▶ or ▶ button.**

Use the ▼▲◀▶ buttons to move the projected image.

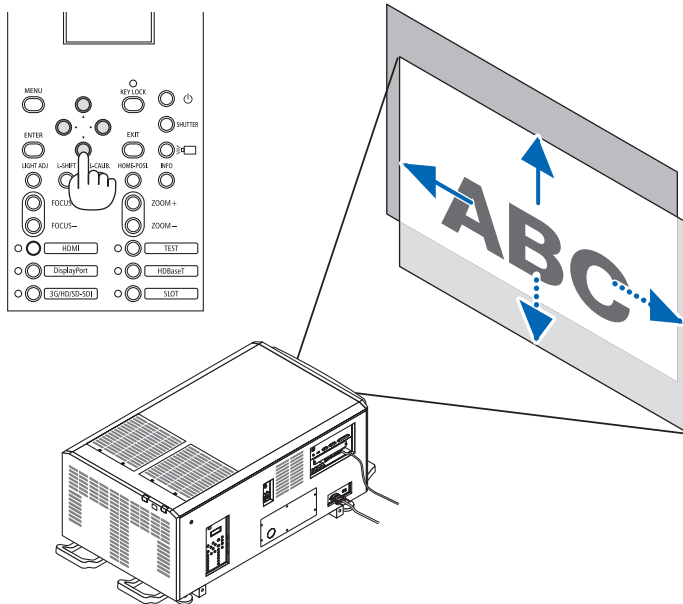

- Returning the lens shift position to the home position

Press the HOME-POS1. button to return the lens shift position to the home position (nearly center position)

## 4. Projector Adjustment and Connecting

### Adjusting with the remote control

#### 1. Hold the CTL button and press the ECO/L-SHIFT button.

The [LENS SHIFT] screen will be displayed.

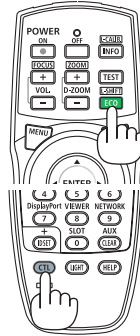
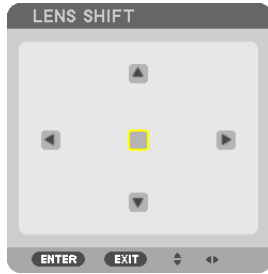

#### 2. Press the ▼▲◀▶ or ▶ button.

Use the ▼▲◀▶ buttons to move the projected image.

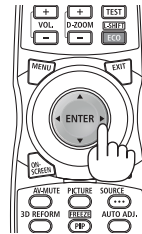

#### TIP:

- The figure below shows the lens shift ranges (projection mode: desktop/front) for 3840 × 2160 images (16:9 aspect ratio) for the L4K-11ZM, L4K-15ZM and L4K-20ZM lens units. See page 10 for the details of other lenses.

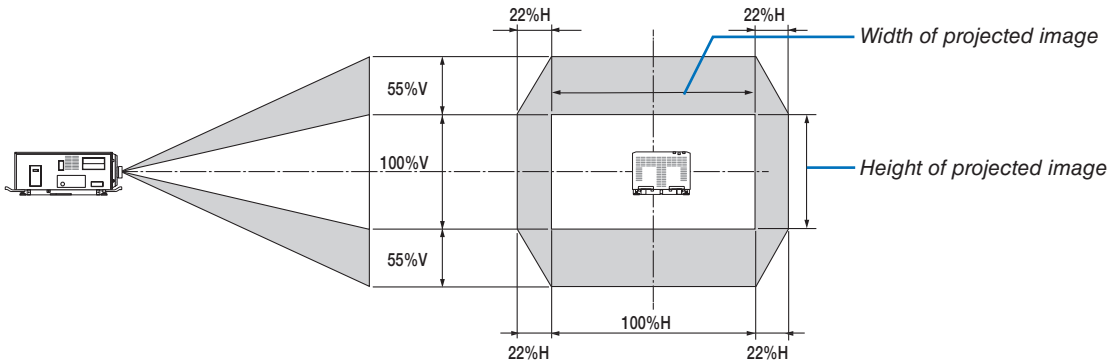

Description of symbols: V indicates vertical (height of the projected image), H indicates horizontal (width of the projected image).



### 4-4-3. Focus

For the L4K-11ZM, L4K-15ZM and L4K-20ZM lens units, perform the image surface adjustment before adjusting the focus. (→ [next page](#))

#### 1. Press the FOCUS +/- button.

The FOCUS adjustment bar will be displayed on.



The focus is adjusted.

- On the remote control, while pressing on the CTL button, press on VOL/FOCUS (+) or (-) button.
- ◀ or ▶ buttons on the cabinet or the remote control are also available to adjust FOCUS while the FOCUS adjustment bar is displayed on.

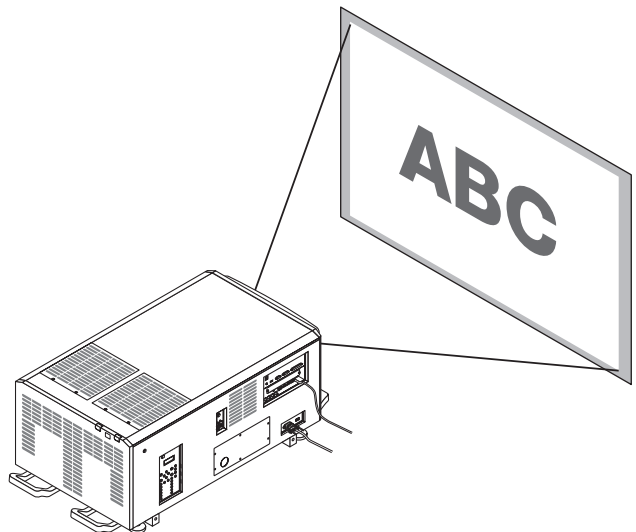
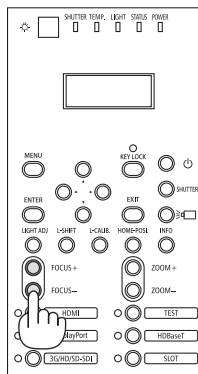
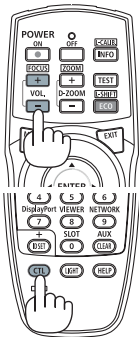

**TIP:** To obtain the best focus, perform the following (for fixed installation)

Preparation: Warm up the projector for one hour.

1. Use the FOCUS +/- buttons to make sure you obtain the best focus. If you do not, move the projector back and forth.
2. Press the TEST button on the remote control to display the test pattern.
3. Keep pressing the FOCUS - button until the grid of the text pattern is made invisible.
4. Keep pressing the FOCUS + button until you obtain the best focus.

If you adjust beyond the best focal point, go back to step 3 and repeat the procedures.

## 4. Projector Adjustment and Connecting

### Lens image surface adjustment

(Applicable lens units: L4K-11ZM, L4K-15ZM and L4K-20ZM)

When using the L4K-11ZM, L4K-15ZM or L4K-20ZM lens units, perform the image surface adjustment before adjusting the lens' focus.

#### Adjustment procedure

1. **Loosen the lock bolt.**

2. **Set the dial to the value of the projection distance.**

*Example: If the projection distance is 20 m, set the dial to between 15 and 25.*

3. **Tighten the lock bolt.**

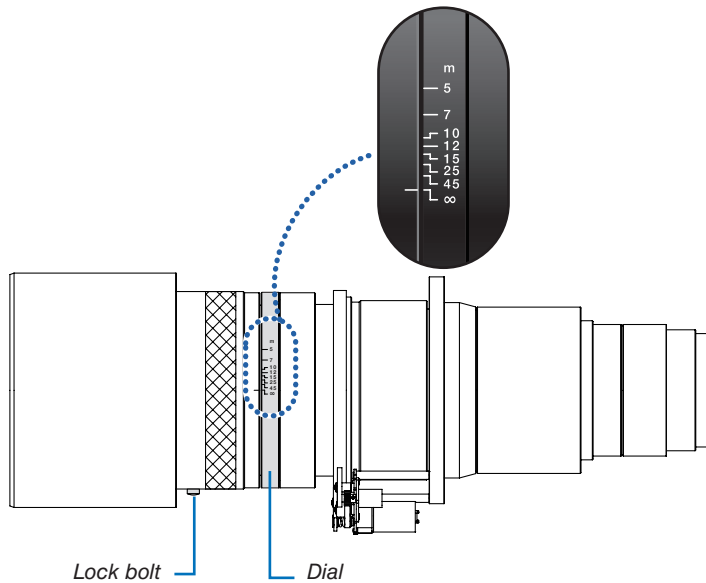

### 4-4-4. Zoom

#### 1. Press the ZOOM +/- button.

The ZOOM adjustment bar will be displayed on.



The zoom is adjusted.

- On the remote control, while pressing on the CTL button, press the D-ZOOM/ZOOM (+) or (-) button.
- ◀ or ▶ buttons on the cabinet or the remote control are available to adjust ZOOM while the ZOOM adjustment bar is displayed on.
- The zoom of the lens unit L2K-10F1 cannot be adjusted.

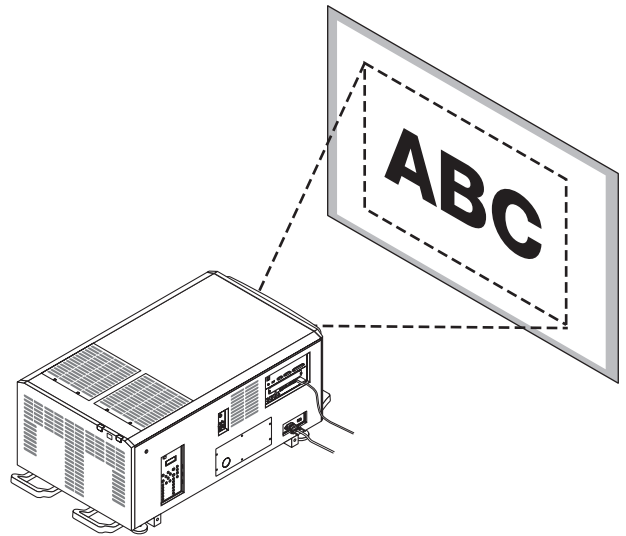
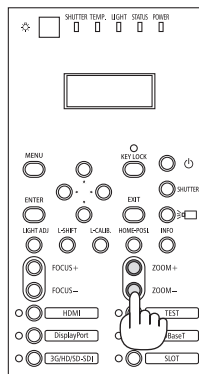
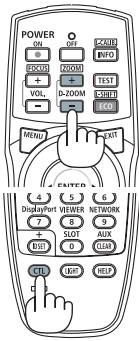

## 4-5. Connecting to Other Equipments

### 4-5-1. Connecting to external equipments

Below is an example of connections to external equipment.

No connection cables are included with this unit. Use the appropriate cables for the connections.

#### CAUTION

For HDMI, DisplayPort, BNC and LAN, please use a shielded cable.

Use of other cables may cause interference with radio and television reception.

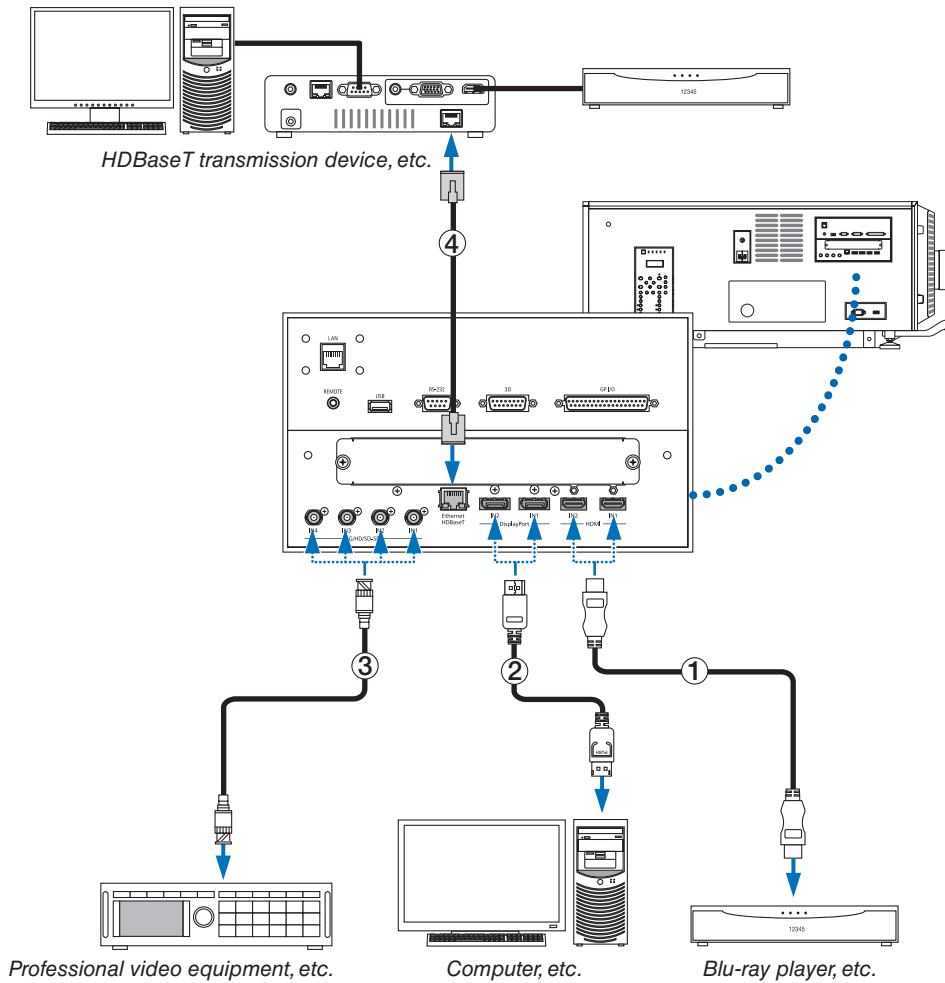

## 4. Projector Adjustment and Connecting

### ① HDMI cable (not supplied)

- Use a certified High Speed HDMI® Cable or High Speed HDMI® Cable with Ethernet.
- When connecting the HDMI 1 IN or HDMI 2 IN connector of the projector to the Blu-ray player, the projector's video level can be made settings in accordance with the Blu-ray player's video level. In the menu select [ADJUST] → [VIDEO] → [VIDEO LEVEL] and make necessary settings.

### ② DisplayPort cable (not supplied)

- Use a certified DisplayPort cable.



### ③ BNC cable (not supplied)

- Use cables that are 5C-FB or higher (5C-FB, 7C-FB, etc.) or Belden 1694A or higher. In addition, use cables with a cable length 100m or less.
- The length of cables that can be used may differ, depending on the signal.

### ④ LAN cable (not supplied)

- Please use a shielded twisted pair (STP) cable of Category 5e or higher for the LAN cable (sold commercially).
- The HDBaseT port of the projector supports HDMI signals (HDCP) from transmission devices, control signals from external devices (serial, LAN) and remote control signals (IR commands).
- The maximum transmission distance over the LAN cable is 100 m. (the maximum distance is 70 m for a 4K signal)
- Please do not use other transmission equipment between the projector and transmission equipment. The picture quality may be degraded as a result.
- This projector is not guaranteed to work with all HDBaseT transmission devices sold commercially.

After turning on the power of the unit, select the input according to the connection terminal.

Input connector	Button on the projector cabinet	Button on the remote control	Note
HDMI1/2 IN	HDMI	HDMI	Switches between HDMI1 and HDMI2 each time it is pressed.
DisplayPort 1/2 IN	DisplayPort	DisplayPort	<ul style="list-style-type: none"><li>• Switches between DisplayPort1 and DisplayPort2 each time it is pressed.</li><li>• Select DisplayPort1 for dual link.</li></ul>
SDI 1/2/3/4 IN	3G/HD/SD-SDI	AUX	<ul style="list-style-type: none"><li>• Switches between SDI1, SDI2, SDI3 and SDI4 each time it is pressed.</li><li>• Select SDI1 for quad link or dual link.</li></ul>
HDBaseT	HDBaseT	NETWORK	—

### 4-5-2. Mounting the Optional Board (sold separately)



**CAUTION**

- Before mounting or removing the optional board, check that the projector power switch and light power switch of the projector is turned off. Implement the connection with AC power shut off.

Tool needed: Phillips screwdriver (plus-head)

#### 1. Loosen the two screws on the SLOT cover of the LV unit.

Remove the two screws and the SLOT cover.

**NOTE:**

- Keep the two screws and the slot cover.

#### 2. Insert the optional board into the slot.

Make sure that the board is inserted into the slot in the correct orientation.

Incorrect orientation may cause miscommunication between the optional board and projector.

#### 3. Tighten the two screws on both sides of the slot.

- Be sure to tighten the screws.

This will complete installation of the optional board.

To select the optional board source, select SLOT as the input.

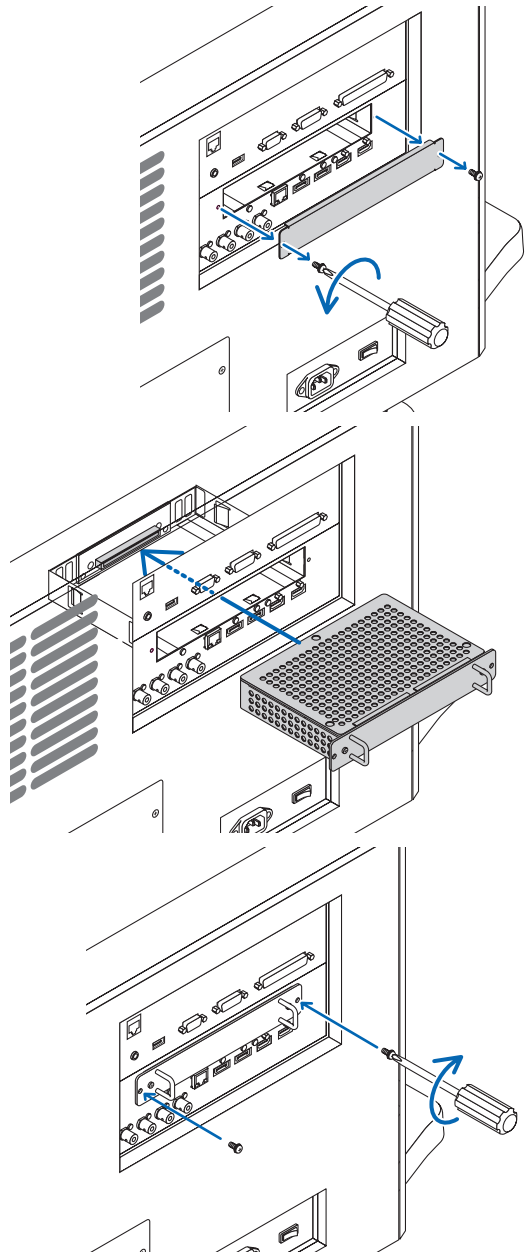

### 4-6. Turning off the Projector

To turn off the projector:

1. First, press the  (POWER) button on the projector cabinet or the POWER OFF button on the remote control. The [POWER OFF / ARE YOU SURE ?] message will appear.

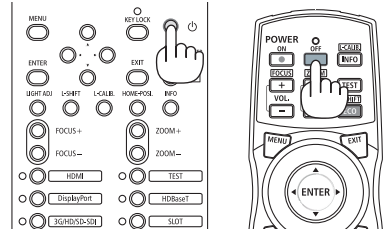
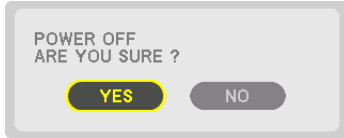

2. Secondly, press the ENTER button or press the  (POWER) or the POWER OFF button again.

When the projector is in STANDBY MODE, the POWER indicator lights up orange.

- Before the POWER indicator lights up orange, the buzzer sound is released when [NOTIFICATION SETTING] for [BUZZER] is ON.

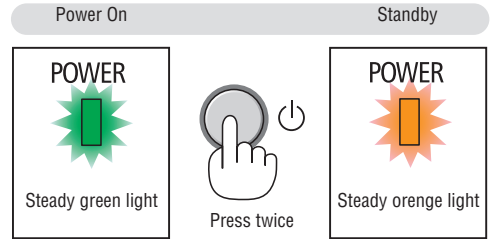

3. After the projector enters the standby state, turn off the projector power switch ([1]), then the light power switch ([2]).

The POWER indicator will go off and the main power will turn off.

- While the POWER indicator is blinking green in short cycles, the power cannot be turned off.

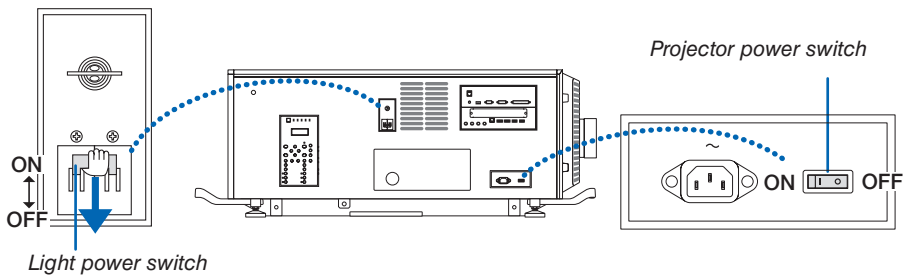

4. Return the administrator switch to the OFF position, then remove the administrator key.

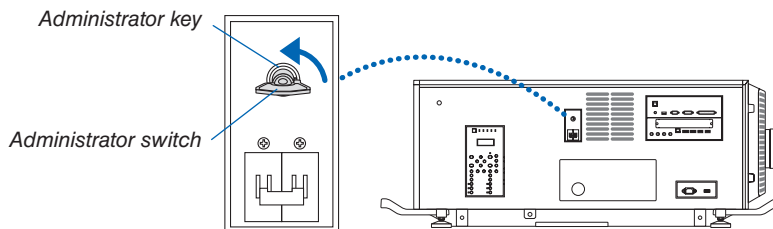

5. Turn off the AC power to the projector.

## 4. Projector Adjustment and Connecting

---

**NOTE:**

- *In the following instances, do not turn off the projector power switch and light power switch or disconnect the AC power. Doing so can damage the projector.*
    - *While projecting images*
    - *While the power is on*
    - *During the cooling after the power is turned off.*
  - *After you have made the adjustments and closed the adjustment screen, do not turn off the projector power switch and light source power switch, or pull out the power plug from the wall outlet, or shut down the AC power supply for about 10 seconds. The adjustment values may be initialized if the AC power supply is shut down during this time.*
-



# 5. List of Menu Items

Some menu items are not available depending on the input source.

- Basic menu items are indicated by shaded area.

Menu Item	Default	Options		
INPUT	HDMI1			
	HDMI2			
	DisplayPort1			
	DisplayPort2			
	HDBaseT			
	SDI1			
	SDI2			
	SDI3			
	SDI4			
	SLOT			
	ENTRY LIST			
TEST PATTERN				
ADJUST	MODE	STANDARD	STANDARD, PROFESSIONAL	
	PRESET	*	AUTO, 1:HIGH-BRIGHT, 2:PRESENTATION, 3:REC709, 4:CINEMA, 5:REC2020, 6:sRGB, 7:DICOM SIM.	
	DETAIL SETTINGS	GENERAL		
		REFERENCE	*	HIGH-BRIGHT, PRESENTATION, REC709, CINEMA, REC2020, sRGB, DICOM SIM.
		GAMMA SETTING* <sup>1</sup>		
		SCREEN SIZE* <sup>2</sup>	*	LARGE, MEDIUM, SMALL
		COLOR TEMPERATURE* <sup>3</sup>	*	
		DYNAMIC CONTRAST	*	OFF, MOTION IMAGE, STILL IMAGE
		LIGHT MODE		
		LIGHT ADJUST		
		CONSTANT BRIGHTNESS	OFF	OFF, ON
		WHITE BALANCE		
		CONTRAST R	0	
		CONTRAST G	0	
		CONTRAST B	0	
		BRIGHTNESS R	0	
		BRIGHTNESS G	0	
		BRIGHTNESS B	0	
		COLOR CORRECTION		
		RED	0	HUE, SATURATION
		GREEN	0	HUE, SATURATION
	BLUE	0	HUE, SATURATION	
	YELLOW	0	HUE, SATURATION	
	MAGENTA	0	HUE, SATURATION	
	CYAN	0	HUE, SATURATION	
	COLOR SETTING			
	SETTINGS		ON, OFF	
	MCGD		REFERENCE, RED, GREEN, BLUE, WHITE, OK, CHANCEL	
	TCGD		REFERENCE, RED, GREEN, BLUE, CYAN, MAGENTA, YELLOW, WHITE, SAVE, OK, CHANCEL	
	CONTRAST	50		
	BRIGHTNESS	50		
	SHARPNESS	10		
	COLOR	50		
	HUE	0		
	RESET			
	IMAGE OPTIONS	HORIZONTAL	*	
		VERTICAL	*	
		BLANKING	*	TOP, BOTTOM, LEFT, RIGHT
		OVERSCAN		AUTO, 0[%], 5[%], 10[%]
		ASPECT RATIO	AUTO	(HDTV/SDTV) AUTO, NORMAL, 4:3, LETTERBOX, WIDE SCREEN, ZOOM, FULL
VIDEO	NOISE REDUCTION	OFF	OFF, LOW, MEDIUM, HIGH	
	DEINTERLACE	NORMAL	NORMAL, MOVIE, STILL	
	CONTRAST ENHANCEMENT	AUTO	OFF, AUTO, NORMAL	
	SIGNAL TYPE	AUTO	AUTO, RGB, REC601, REC709, REC2020	
	VIDEO LEVEL	AUTO	AUTO, NORMAL, ENHANCED, SUPER WHITE	
	HDR MODE	AUTO	AUTO, OFF, ON	

\* The asterisk (\*) indicates that the default setting varies depending on the signal.

\*<sup>1</sup> The [GAMMA SETTING] item is available when an item other than [DICOM SIM.] is selected for [REFERENCE].

\*<sup>2</sup> The [SCREEN SIZE] item is available when [DICOM SIM.] is selected for [REFERENCE].

\*<sup>3</sup> When [HIGH-BRIGHT] or [PRESENTATION] is selected in [REFERENCE], the [COLOR TEMPERATURE] is not available.

## 5. List of Menu Items

Menu Item		Default	Options		
ADJUST	3D SETTINGS(1)	STEREO VIEWER	SINGLE		
		FORMAT	AUTO		
		3D DETAIL SETTINGS	OFF		
	3D SETTINGS(2)	L/R DISPLAY REF.	NOT USE	NOT USED, USE GPI(TRUE), USE GPI(INVERT)	
		DELAY			
			TIME		
			PHASE		
		FRAME RATE RATIO	1:1	1 : 1, 4 : 1, 6 : 1, 2 : 2, 4 : 2, 6 : 2	
		INPUT FRAME DOMINANCE	LEFT(L1R1 L2R2)	LEFT(L1R1 L2R2), RIGHT(R1L1 R2L2)	
		L/R OUTPUT REF. POLARITY	TRUE	TRUE, INVERT	
	DARK TIME				
	L/R INPUT REF.	USE PORT(TURE)	NONE PROVIDED, USE GPI(TRUE), USE GPI(INVERT), USE PORT(TURE), USE PORT(INVERT)		
	LENS MEMORY	STORE			
		MOVE			
		RESET			
LOAD BY SIGNAL		OFF	OFF, ON		
FORCED MUTE		OFF	OFF, ON		
DISPLAY	PICTURE BY PICTURE	MODE	OFF	OFF, DUAL, QUAD	
		SUB1 INPUT		SDI1, SDI2, SDI3, SDI4, HDMI1, HDMI2, DisplayPort1, DisplayPort2, HDBaseT, SLOT	
		SUB2 INPUT		SDI1, SDI2, SDI3, SDI4, HDMI1, HDMI2, DisplayPort1, DisplayPort2	
		SUB3 INPUT		SDI1, SDI2, SDI3, SDI4, HDMI1, HDMI2, DisplayPort1, DisplayPort2	
		PORTRAIT ANGLE	0°	0°, 90°, 270°	
		MAIN POSITION			
	SUB POSITION				
	GEOMETRIC CORRECTION	MODE	OFF	OFF, KEYSTONE, CORNERSTONE, HORIZONTAL CORNER, VERTICAL CORNER, WARP, PC TOOL	
		KEYSTONE	HORIZONTAL		
			VERTICAL		
			TILT		
			THROW RATIO		
		CORNERSTONE		TOP-LEFT, TOP, TOP-RIGHT, LEFT, RIGHT, BOTTOM-LEFT, BOTTOM, BOTTOM-RIGHT	
		HORIZONTAL CORNER		TOP-LEFT, TOP, TOP-RIGHT, LEFT, RIGHT, BOTTOM-LEFT, BOTTOM, BOTTOM-RIGHT	
		VERTICAL CORNER		TOP-LEFT, TOP, TOP-RIGHT, LEFT, RIGHT, BOTTOM-LEFT, BOTTOM, BOTTOM-RIGHT	
WARP		TOP-LEFT, TOP, TOP-RIGHT, LEFT, RIGHT, BOTTOM-LEFT, BOTTOM, BOTTOM-RIGHT			
PC TOOL	OFF	OFF, 1, 2, 3			
RESET					
EDGE BLENDING	MODE	OFF	OFF, ON		
	MARKER	OFF	OFF, ON		
	TOP	CONTROL	OFF	OFF, ON	
		RANGE			
		POSITION			
	BOTTOM	CONTROL	OFF	OFF, ON	
		RANGE			
		POSITION			
	LEFT	CONTROL	OFF	OFF, ON	
		RANGE			
		POSITION			
	RIGHT	CONTROL	OFF	OFF, ON	
RANGE					
POSITION					
BLEND CURVE	5	OFF, 1, 2, 3, 4, 5, 6, 7, 8, 9			
BLACK LEVEL	CENTER		REFERENCE, RED, GREEN, BLUE, RESET		
	TOP				
	BOTTOM				
	LEFT				
	RIGHT				
	BORDER(TOP)				
	BORDER(BOTTOM)				
BORDER(LEFT)					
BORDER(RIGHT)					

## 5. List of Menu Items

Menu Item		Default	Options		
DISPLAY	PICTURE SETTING	MODE	OFF	OFF, ZOOM	
		ZOOM	HORIZONTAL ZOOM		
			VERTICAL ZOOM		
			HORIZONTAL POSITION		
			VERTICAL POSITION		
		TILING	WIDTH		
			HEIGHT		
			HORIZONTAL POSITION		
	VERTICAL POSITION				
	MULTI SCREEN	WHITE BALANCE	MODE		
			CONTRAST W		
			CONTRAST R		
			CONTRAST G		
			CONTRAST B		
BRIGHTNESS W					
BRIGHTNESS R					
BRIGHTNESS G					
BRIGHTNESS B					
SETUP	MENU(1)	LANGUAGE	ENGLISH	ENGLISH, DEUTSCH, FRANÇAIS, ITALIANO, ESPAÑOL, SVENSKA, 日本語 DANSK, PORTUGUÊS, ČEŠTINA, MAGYAR, POLSKI, NEDERLANDS, SUOMI NORSK, TÜRKÇE, РУССКИЙ, عربي, Ελληνικά, 简体中文, 한국어 ROMÂNĂ, HRVATSKA, БЪЛГАРСКИ, INDONESIA, हिन्दी, ไทย, ភ្នំខ្មែរ, 繁體中文, Tiếng Việt	
		COLOR SELECT	COLOR	COLOR, MONOCHROME	
		INPUT DISPLAY	ON	OFF, ON	
		MESSAGE DISPLAY	ON	OFF, ON	
		ID DISPLAY	OFF	OFF, ON	
		3D CAUTION MESSAGE	ON	OFF, ON	
		DISPLAY TIME	AUTO 45 SEC	MANUAL, AUTO 5 SEC, AUTO 15 SEC, AUTO 45 SEC	
		FILTER MESSAGE	OFF	OFF, 100[H], 500[H], 1000[H], 2000[H], 5000[H], 10000[H], 20000[H]	
	MENU(2)	MENU ANGLE	0°	0°, 90°, 270°	
		MENU POSITION	CENTER	TOP-LEFT, TOP-CENTER, TOP-RIGHT, CENTER-LEFT, CENTER, CENTER-RIGHT, BOTTOM-LEFT, BOTTOM-CENTER, BOTTOM-RIGHT	
	INSTALLATION(1)	ORIENTATION	DESKTOP FRONT	DESKTOP FRONT, CEILING REAR, DESKTOP REAR, CEILING FRONT	
		SCREEN TYPE	FREE	FREE, 4:3 SCREEN, 16:9 SCREEN, 16:10 SCREEN	
		WALL COLOR	OFF	OFF, WHITEBOARD, BLACKBOARD, BLACKBOARD (GRAY), LIGHT YELLOW, LIGHT GREEN, LIGHT BLUE, SKY BLUE, LIGHT ROSE, PINK	
		FAN MODE	AUTO	AUTO, HIGH, LOW	
		REF. LIGHT MODE	REF. LIGHT ADJUST		
			CONSTANT BRIGHTNESS	OFF	OFF, ON
		REF. WHITE BALANCE	CONTRAST R		
			CONTRAST G		
			CONTRAST B		
			BRIGHTNESS R		
			BRIGHTNESS G		
			BRIGHTNESS B		
		STATIC CONVERGENCE	UNIFORMITY R		
			UNIFORMITY B		
	HORIZONTAL R				
	HORIZONTAL G				
	HORIZONTAL B				
VERTICAL R					
VERTICAL G					
VERTICAL B					
INSTALLATION(2)	SHUTTER SETTINGS	POWER ON SHUTTER	OPEN	OPEN, CLOSE	
		PICTURE MUTE SHUTTER	OPEN	OPEN, CLOSE	
		FADE IN TIME		0-10 SEC	
		FADE OUT TIME		0-10 SEC	
	REF. LENS MEMORY	PROFILE	1	1, 2	
		STORE			
		MOVE			
		RESET			
		LOAD BY SIGNAL	OFF	OFF, ON	
		FORCED MUTE	OFF	OFF, ON	
LENS POSITION	HOME				
LENS CALIBRATION					

## 5. List of Menu Items

Menu Item			Default	Options				
SETUP	CONTROL	TOOLS	ADMINISTRATOR MODE		MENU MODE	ADVANCED	ADVANCED, BASIC	
			NOT SAVE SETTING VALUES		OFF	OFF, ON		
			NEW PASSWORD					
			CONFIRM PASSWORD					
			PROGRAM TIMER		ENABLE	OFF	OFF, ON	
			SETTINGS		EDIT	ACTIVE	OFF	OFF, ON
						DAY	SUN	SUN, MON, TUE, WED, THU, FRI, SAT, MON-FRI, MON-SAT, EVERY DAY
						TIME		
						FUNCTION	POWER	POWER, INPUT
						ADVANCED SETTINGS		
						POWER	OFF	OFF, ON
						INPUT	HDMI1	HDMI1, HDMI2, DisplayPort1, DisplayPort2, HDBaseT, SDI1, SDI2, SDI3, SDI4, SLOT
						REPEAT	OFF	OFF, ON
						DELETE UP		
						DOWN BACK		
			TIME ZONE SETTINGS		UTC		-12:00, -11:30, -11:00, -10:30, -10:00, -09:30, -09:00, -08:30, -08:00, -07:30, -07:00, -06:30, -06:00, -05:30, -05:00, -04:30, -04:00, -03:30, -03:00, -02:30, -02:00, -01:30, -01:00, -00:30, 00:00, +00:30, +01:00, +01:30, +02:00, +02:30, +03:00, +03:30, +04:00, +04:30, +05:00, +05:30, +06:00, +06:30, +07:00, +07:30, +08:00, +08:30, +09:00, +09:30, +10:00, +10:30, +11:00, +11:30, +12:00, +12:30, +13:00	
			DATE AND TIME SETTINGS		DATE MM/DD/YYYY			
					TIME HH:MM			
					INTERNET TIME SERVER		OFF, ON	
					IP ADDRESS			
					UPDATE			
			SUMMER TIME SETTINGS		ENABLE		OFF, ON	
					MON(START)		1, 2, 3, 4, 5, 6, 7, 8, 9, 10, 11, 12	
					DAY(START)		FIRST WEEK, SECOND WEEK, THIRD WEEK, FOURTH WEEK, LAST WEEK	
							SUN, MON, TUE, WED, THU, FRI, SAT	
					TIME(START)			
					MON(EXIT)		1, 2, 3, 4, 5, 6, 7, 8, 9, 10, 11, 12	
					DAY(EXIT)		FIRST WEEK, SECOND WEEK, THIRD WEEK, FOURTH WEEK, LAST WEEK	
							SUN, MON, TUE, WED, THU, FRI, SAT	
			TIME(EXIT)					
					TIME DIFFERENCE		+01:00, +00:30, -00:30, -01:00	
			CONTROL PANEL LOCK			OFF	OFF, ON	
			NOTIFICATION SETTINGS		REAR LED	ON	OFF, ON	
					BUZZER	ON	OFF, ON	
			SECURITY			OFF	OFF, ON	
			COMMUNICATION SPEED			38400bps	4800bps, 9600bps, 19200bps, 38400bps, 115200bps	
			CONTROL ID		CONTROL ID NUMBER	1	1-254	
					CONTROL ID	OFF	OFF, ON	
			REMOTE SENSOR			FRONT/BACK	FRONT/BACK, FRONT, BACK, HDBaseT	

## 5. List of Menu Items

Menu Item		Default	Options			
SETUP	NETWORK SETTINGS	WIRED LAN	INTERFACE	LAN, HDBaseT		
			PROFILES	PROFILE 1, PROFILE 2		
			DHCP	OFF, ON		
			IP ADDRESS			
			SUBNET MASK			
			GATEWAY			
			AUTO DNS	OFF, ON		
			DNS CONFIGURATION			
		RECONNECT				
		PROJECTOR NAME	PROJECTOR NAME	PJ-*****		
		DOMAIN	HOST NAME	pj-*****		
			DOMAIN NAME			
		ALERT MAIL	ALERT MAIL	OFF, ON		
			HOST NAME	pj-*****		
			DOMAIN NAME			
			SENDER'S ADDRESS			
			SMTP SERVER NAME			
			RECIPIENT'S ADDRESS 1			
			RECIPIENT'S ADDRESS 2			
			RECIPIENT'S ADDRESS 3			
		TEST MAIL				
		NETWORK SERVICE	HTTP SERVER	NEW PASSWORD		
				CONFIRM PASSWORD		
			PJLink	NEW PASSWORD		
				CONFIRM PASSWORD		
			CLASS	CLASS1, CLASS2		
			DESTINATION			
		AMX BEACON	OFF, ON			
		Extron XTP	OFF, ON			
		SOURCE OPTIONS(1)	DEFAULT INPUT SELECT		LAST	LAST, AUTO, HDMI1, HDMI2, DisplayPort1, DisplayPort2, HDBaseT, SDI1, SDI2, SDI3, SDI4, SLOT
			SEAMLESS SWITCHING		OFF	OFF, ON
			BACKGROUND		BLUE	BLUE, BLACK, LOGO
	EDID VERSION		HDMI1	MODE2	MODE1, MODE2	
			HDMI2	MODE2	MODE1, MODE2	
	HDCP VERSION		HDMI1	HDCP2.2	HDCP2.2, HDCP1.4	
			HDMI2	HDCP2.2	HDCP2.2, HDCP1.4	
		HDBaseT	HDCP1.4	HDCP2.2, HDCP1.4		
	SOURCE OPTIONS(2)	SDI LINK			SINGLE, QUAD, QUAD (2SI), DUAL	
		DP LINK			SINGLE, DUAL	
	POWER OPTIONS	DIRECT POWER ON		OFF	OFF, ON	
		AUTO POWER ON SELECT		OFF	OFF, HDMI1, HDMI2, DisplayPort1, DisplayPort2, HDBaseT, SDI1, SDI2, SDI3, SDI4, SLOT	
		AUTO POWER OFF		OFF	OFF, 0:05, 0:10, 0:15, 0:20, 0:30, 1:00	
OFF TIMER		OFF	OFF, 0:30, 1:00, 2:00, 4:00, 8:00, 12:00, 16:00			
SLOT POWER		PROJECTOR ON		ON	OFF, ON	
		PROJECTOR STANDBY		ENABLE	DISABLE, ENABLE	
RESET	CURRENT SIGNAL					
	ALL DATA					
	ALL DATA (INCLUDING ENTRY LIST)					
	CLEAR FILTER HOURS					

## 5. List of Menu Items

Menu Item		Default	Options
INFO.	USAGE TIME	LIGHT HOURS USED	
		FILTER HOURS USED	
		LOW FAN MODE HOURS USED	
	SOURCE(1)	INPUT TERMINAL	
		RESOLUTION	
		HORIZONTAL FREQUENCY	
		VERTICAL FREQUENCY	
		SYNC POLARITY	
		SCAN TYPE	
		SOURCE NAME	
		ENTRY NO.	
	SOURCE(2)	SIGNAL TYPE	
		BIT DEPTH	
		VIDEO LEVEL	
		3D FORMAT	
	WIRED LAN(1)	NETWORK INTERFACE	
		IP ADDRESS	
		SUBNET MASK	
		GATEWAY	
		MAC ADDRESS	
	WIRED LAN(2)	DNS	
		NETWORK INTERFACE	
		IP ADDRESS	
		SUBNET MASK	
		GATEWAY	
	VERSION(1)	MAC ADDRESS	
		DNS	
		FIRMWARE	
		DATA	
		FIRMWARE2	
	OTHERS	DATE TIME	
		PROJECTOR NAME	
		MODEL NO.	
		SERIAL NUMBER	
		CONTROL ID*4	
	CONDITIONS	LENS ID	
		INTAKE TEMPERATURE1	
		INTAKE TEMPERATURE2	
		INTAKE TEMPERATURE3	
		INTAKE TEMPERATURE4	
	HDBaseT	ATMOSPHERIC PRESSURE	
		ACIN VOLTAGE	
SIGNAL QUALITY			
OPERATION MODE			
LINK STATUS			
	HDMI STATUS		

\*4 [CONTROL ID] will be displayed when [CONTROL ID] has been set up.

# 6. Maintenance

---

**NOTE**

- Please request your distributor to perform cleaning of the projector inside.
- 

## 6-1. Cleaning the Cabinet

 **WARNING**

- Please do not use a spray containing flammable gas to remove dust attached to the cabinet, etc. Doing so may result in fires.

Be sure to always check that the AC power supply of the projector is disconnected before carrying out maintenance of the projector.

- Wipe with a dry, soft cloth without nap.  
When the cabinet is excessively dirty, wipe with cloth well wrung after being dampened with a neutral detergent diluted with water and then finish up with a dry cloth.  
When you use a chemical dust cloth, follow the instructions in the manual attached to it.
- Do not use a solvent, such as thinner or benzene. The coating may deteriorate or peel off.
- When removing dust on the ventilation opening, suck it off using an adapter with a brush on a vacuum cleaner. Never allow the cleaner without an adapter to come into direct contact or use a nozzle adapter in cleaning.
- Clean the ventilation opening at regular intervals. Dust, if allowed to accumulate there, may cause heating inside, which leads to functional trouble. The interval, which can vary with the location of your projector, is about 100 hours.
- Do not damage the cabinet by scratching it or allowing hard objects to hit it. This can scratch the projector.
- Consult your dealer/distributor about cleaning the inside of the projector.

**NOTE**

- Do not allow insecticide or other volatile liquid to splash on the cabinet, lens or screen. Also, do not allow any rubber or plastic object to remain in contact with the cabinet for a long time. The coating may deteriorate or peel off.
- 

## 6-2. Cleaning the Lens

Clean the lens the same way as with camera lens (using a commercially available camera blower or cleaning paper for glasses). Take care not to damage the lens when cleaning.

 **WARNING**

- Do not look into the light source while the projector is ON. Strong light is emitted from the projector and visual impairment could result.
- Please do not use a spray containing flammable gas to remove dust attached to the lens, etc. Doing so may result in fires.

 **CAUTION**

- Before cleaning the lens, first turn off the power, make sure the cooling fan has completely stopped, then turn off the AC power. Make sure the unit has cooled down completely before cleaning the lens.

## 6-3. Cleaning the Air Filters

Air filters are attached over the air inlet of the projector to prevent dust. The air filters should be cleaned periodically in order to maintain projector performance.

### WARNING

- Dust in air filters will hinder ventilation of the projector, lead to a rise of the internal temperature and can cause a fire or malfunction.
- Please do not use a spray containing flammable gas to remove dust attached to the filters, etc. Doing so may result in fires.

### CAUTION

- Before cleaning the filter, first turn off the power, make sure the cooling fan has completely stopped, then turn off the AC power. Make sure the unit has cooled down completely before cleaning the filter. Removing the filter cover while the unit is running could result in burns or electric shock from contact with internal parts.

The unit uses a two layer metal-mesh filter installed behind the filter cover. With regular cleaning it can be used repeatedly.

When cleaning the air filter, clean it all at the same time.

*Air inlet (Filter cover / Filter)*

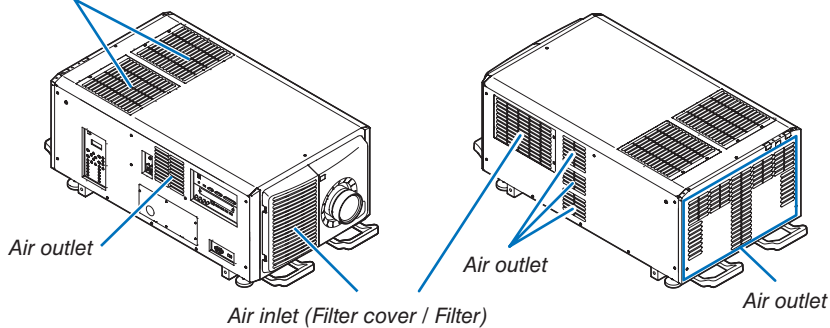

### 6-3-1. Cleaning the Air Filter

#### 1. Remove the front filter cover.

*Pull the front filter cover in the direction of the arrow to remove.*

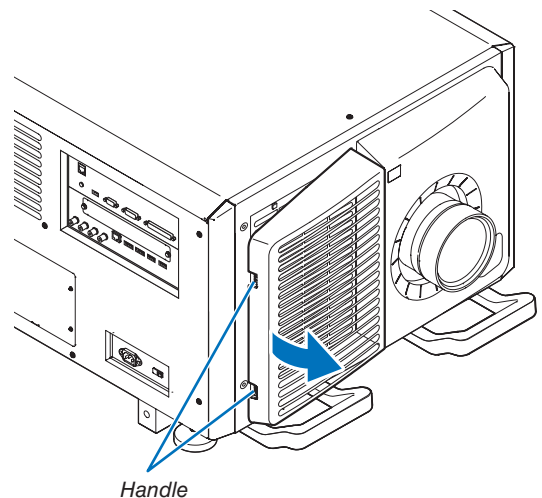



### 2. Remove the air filter.

(1) Press the stopper button (2 places).

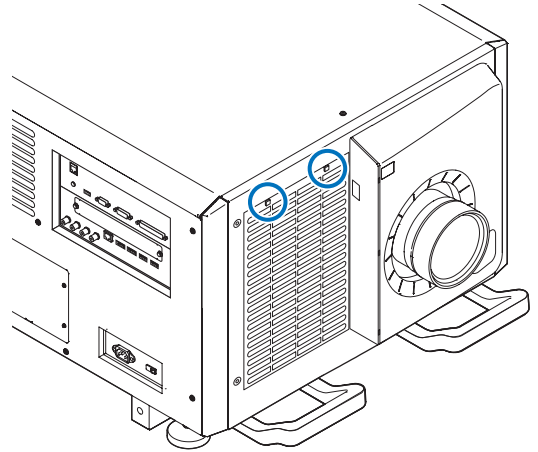

(2) Pull the top part of the air filter towards you. Once you have freed the upper half of the air filter, remove the filter by pulling it diagonally upwards.

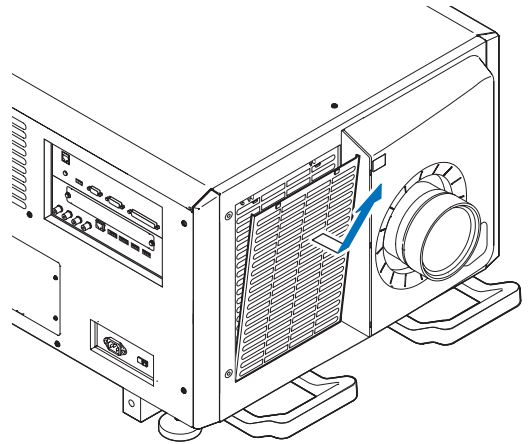

3. Lift the air filter in the direction of the arrow and remove it.

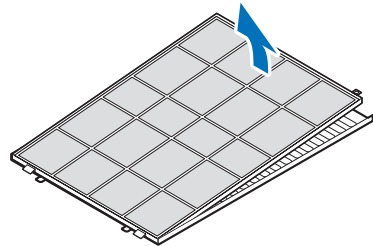

### 4. Remove the air filters.

(1) Slide the upper air filter to the position shown below.

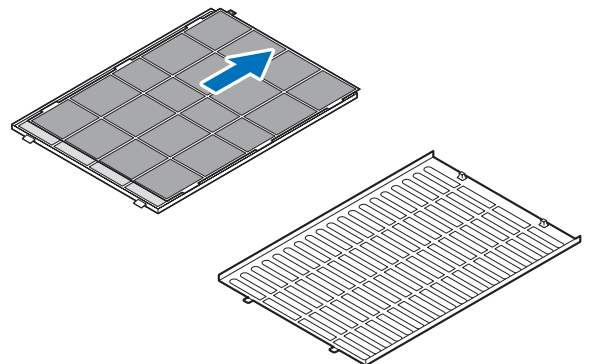

(2) Lift the upper air filter in the direction of the arrow and remove it.

**NOTE**

- Do not apply a high degree of force or attempt to pry it open. This could deform the flange making it impossible to reattach the filter cover.

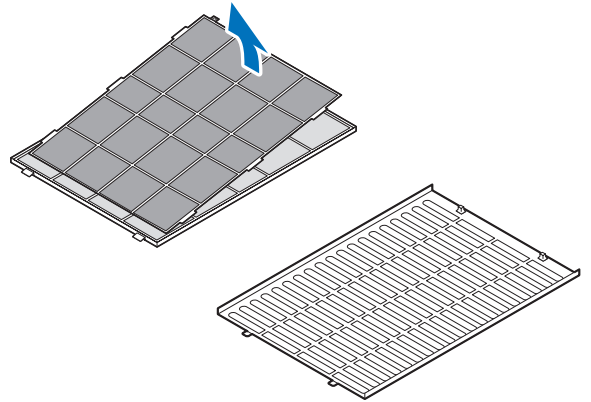

**5. Clean all the dust from the filters using a vacuum cleaner.**

(1) Carefully remove the dust from the filter covers as well as from both sides of all the filters.

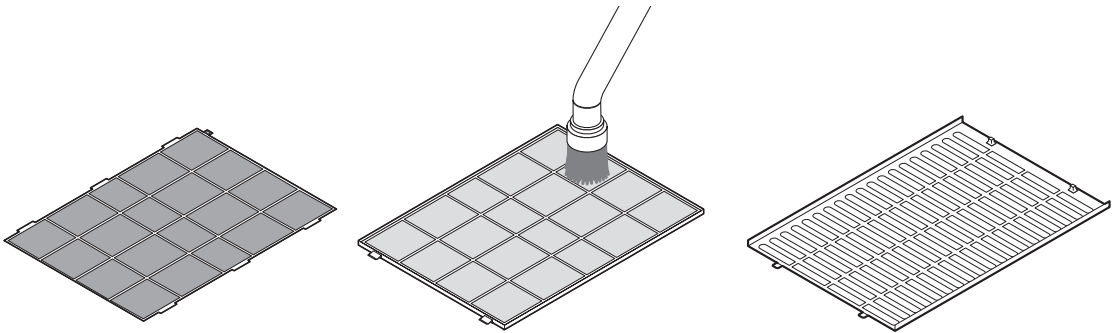

(2) Remove the dust from the grates on the outside of the projector as well.

Be sure to also remove any dust stuck to the louver (blind with angled horizontal slats) with a vacuum cleaner.

**NOTE**

- Whenever you vacuum the filter, use the soft brush attachment to vacuum. This is to avoid damage to the filter.
- Do not wash the filter with water. Doing so can result in damage to the filter membrane and also cause clogging.

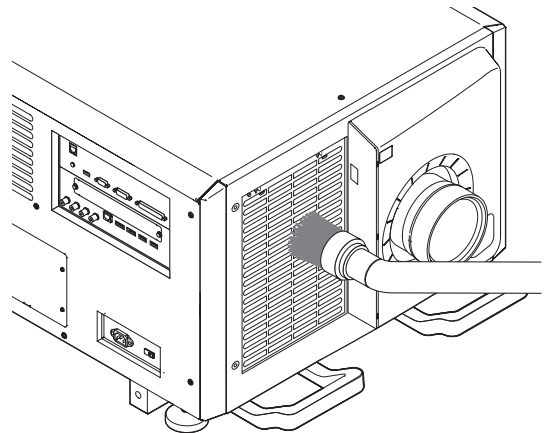

**6. Put the various parts of the filter together and fit them inside the filter cover.**

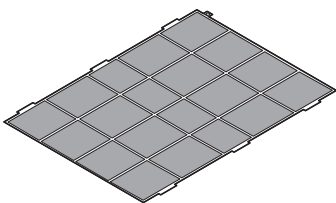

Coarse grade filter

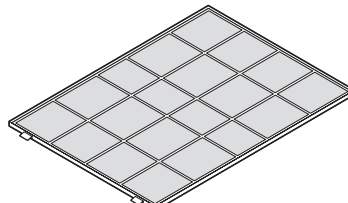

Fine grade filter

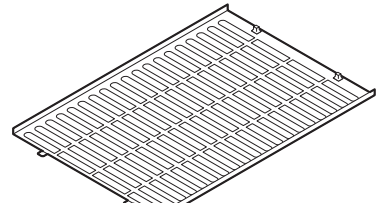

Filter cover

### 7. Fix the filter inside the projector unit.

- (1) Snap the filter cover tabs into the cutout portion of the projector unit to secure it.
- (2) Seat the air filter aligned with the air inlet.

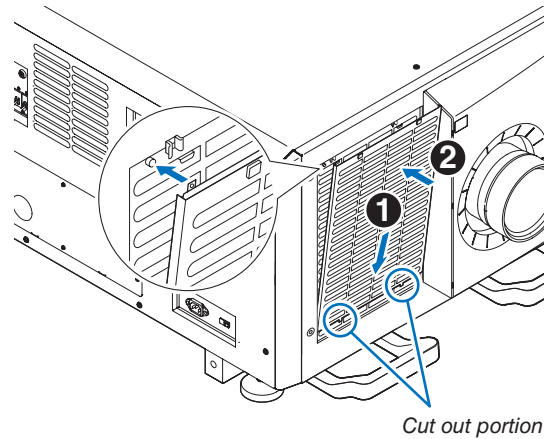

### 8. Attach the front filter cover.

- Push the front filter cover in the direction of the arrow to install.

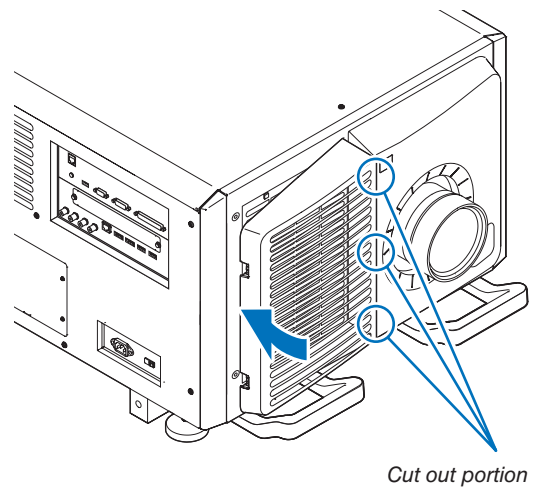

### 9. Clean the other intake vent air filters in the same way.

- Clean the other intake vent air filters in the same way as in steps (2) to (7).

#### NOTE

- Before turning on the power, make sure that all filter covers are in place. If they are not fitted properly dust could get inside the projector causing it to malfunction.
- Reset air filter usage time after cleaning the filters.

### 6-3-2. Resetting the Air Filter Usage Time

1. Turn on the power to the projector.
2. Select [SETUP] → [RESET] and perform [CLEAR FILTER HOURS].

This completes resetting the air filter usage time.

# 7. Appendix

## 7-1. Compatible Input Signal List

### HDMI/HDBaseT

Signal	Resolution ( dots )	Aspect Ratio	Refresh Rate ( Hz )
VGA	640 × 480	4 : 3	60/72/75/85/iMac
SVGA	800 × 600	4 : 3	56/60/72/75/85/iMac
XGA	1024 × 768	4 : 3	60/70/75/85/iMac
HD	1280 × 720	16 : 9	60
WXGA	1280 × 768	15 : 9	60
	1280 × 800	16 : 10	60
Quad-VGA	1280 × 960	4 : 3	60
SXGA	1280 × 1024	5 : 4	60
FWXGA	1366 × 768	16 : 9	60
	1366 × 768	16 : 9	60
SXGA+	1400 × 1050	4 : 3	60
WXGA+	1440 × 900	16 : 10	60
WXGA++	1600 × 900	16 : 9	60
WSXGA+	1680 × 1050	16 : 10	60
UXGA	1600 × 1200	4 : 3	60
Full HD	1920 × 1080	16 : 9	60
WUXGA	1920 × 1200 *1	16 : 10	60 (Reduced Blanking)
2K	2048 × 1080 *1	17 : 9	60
WQHD iMac 27"	2560 × 1440 *1	16 : 9	60
WQXGA	2560 × 1600 *1	16 : 10	60 (Reduced Blanking)
	3840 × 2160	16 : 9	24/25/30/50*/60**1
4K	4096 × 2160 *2	17 : 9	24/25/30/50*/60**1
	4096 × 2160	17 : 9	24/25/30/50/60
HDTV (1080p)	1920 × 1080	16 : 9	24/25/30/50/60
HDTV (1080i)	1920 × 1080	16 : 9	48/50/60
HDTV (720p)	1280 × 720	16 : 9	50/60
SDTV (480p)	720/1440 × 480	4:3 / 16:9	60
SDTV (576p)	720/1440 × 576	4:3 / 16:9	50
SDTV (480i)	1440 × 480	4:3 / 16:9	60
SDTV (576i)	1440 × 576	4:3 / 16:9	50

### DisplayPort

Signal	Resolution ( dots )	Aspect Ratio	Refresh Rate ( Hz )
VGA	640 × 480	4 : 3	60
SVGA	800 × 600	4 : 3	60
XGA	1024 × 768	4 : 3	60
HD	1280 × 720	16 : 9	60
WXGA	1280 × 768	15 : 9	60
	1280 × 800	16 : 10	60
Quad-VGA	1280 × 960	4 : 3	60
SXGA	1280 × 1024	5 : 4	60
FWXGA	1366 × 768	16 : 9	60
	1366 × 768	16 : 9	60
SXGA+	1400 × 1050	4 : 3	60
WXGA+	1440 × 900	16 : 10	60
WXGA++	1600 × 900	16 : 9	60
WSXGA+	1680 × 1050	16 : 10	60
UXGA	1600 × 1200	4 : 3	60
Full HD	1920 × 1080	16 : 9	60
WUXGA	1920 × 1200	16 : 10	60 (Reduced Blanking)
2K	2048 × 1080	17 : 9	60
WQHD iMac 27"	2560 × 1440	16 : 9	60
WQXGA	2560 × 1600	16 : 10	60 (Reduced Blanking)
	3840 × 2160	16 : 9	24/25/30/50/60
4K	4096 × 2160 *2	17 : 9	24/25/30/50/60
	4096 × 2160	17 : 9	24/25/30/50/60
HDTV (1080p)	1920 × 1080	16 : 9	24/25/30/50/60
HDTV (720p)	1280 × 720	16 : 9	50/60
SDTV (480i/p)	720/1440 × 480	4:3 / 16:9	60
SDTV (576i/p)	720/1440 × 576	4:3 / 16:9	50

## SDI

Signal	Resolution ( dots )	Aspect Ratio	Refresh Rate ( Hz )
HD-SDI (1035i)	1920 × 1035	16 : 9	60
HD-SDI (1080i)	1920 × 1080	16 : 9	50/60
HD-SDI (1080p)	1920 × 1080	16 : 9	24pSF
HD-SDI (1080p)	1920 × 1080	16 : 9	24/25/30
HD-SDI (720p)	1280 × 720	16 : 9	24/25/30/50/60
3G-SDI (1080p)	1920 × 1080	16 : 9	50/60
3G-SDI (1080p)	1920 × 1080	16 : 9	24/25/30
3G-SDI (1080p)	1920 × 1080	16 : 9	24pSF
3G-SDI (1080i)	1920 × 1080	16 : 9	50/60
Quad SDI	3840 × 2160	16 : 9	24/25/30/50/60
Quad SDI	4096 × 2160 *2	17 : 9	24/25/30/50/60

## HDBaseT / DisplayPort 3D

Signal Resolution ( dots )	Aspect Ratio	Refresh Rate ( Hz )	3D Format
1920 × 1080p	16 : 9	23.98/24	Frame Packing
			Side By Side (Half)
			Top and Bottom
		25	Frame Packing
			Side By Side (Half)
			Top and Bottom
29.97/30	Frame Packing		
	Side By Side (Half)		
	Top and Bottom		
1280 × 720p	16 : 9	23.98/24	Frame Packing
			Side By Side (Half)
			Top and Bottom
		25	Frame Packing
			Side By Side (Half)
			Top and Bottom
29.97/30	Frame Packing		
	Side By Side (Half)		
	Top and Bottom		

\*1 HDBaseT does not support this signal.

\*2 Native resolution

- Upon shipment, the projector is set for signals with standard display resolutions and frequencies, but adjustments may be required depending on the type of computer.

## 7-2. Indicator Messages

This section helps you resolve problems you may encounter while setting up or using the projector.

### POWER Indicator

Indicator display		Projector status	Procedure
Off		Power is off.	–
Flashing	Green (short flashes)	Preparing to power up or cooling the main unit When the projector is in the standby state, the firmware is ready to be updated	Wait a while.
	Green (twice per cycle)	Firmware is ready to be updated	–
	Green (long flashes)	Off timer (enabled) Program timer (off time enabled)	–
	Orange (long flashes)	Program timer (on time enabled)	–
Lit	Green	Power on	–
	Orange	Standby mode	–

### STATUS Indicator

Indicator display		Projector status	Procedure
Off		No problem	–
Flashing	Green (short flashes)	Shutter is closed	–
	Green (long flashes)	Power on (The light module is turned off.)	–
	Orange	Button has been pressed while projector is in key lock mode	The projector's keys are locked. The setting must be canceled to operate the projector.
		Projector's ID number and remote control's ID number do not match	Check the control IDs.
		Projector cooling	Wait a while.
	Red	Error occurring	Contact your distributor or service personnel. Let us know the details displayed on the liquid crystal indicator panel then.
Lit	Green	Power on	–
	Orange	Standby mode	–
	Red	Error requiring service support	Ask your distributor or service personnel for repair. Let us know the details displayed on the liquid crystal indicator panel then.

**LIGHT Indicator**

Indicator display		Projector status	Procedure
Off		The light module is turned off.	–
Lit	Green	Light module lit	–

**TEMP. Indicator**

Indicator display		Projector status	Procedure
Off		No problem	
Flashing	Red	Temperature problem	Ambient temperature is out of the operation temperature. Check if any obstruction stays near the exhaust vent.
Lit	Red	High surrounding temperature	The surrounding temperature is high. Lower the room temperature.

**SHUTTER Indicator**

Indicator display		Projector status
Off		Shutter is open.
Flashing	Green	Performing the lens calibration.
	Orange	Lens calibration implement request.
Lit	Green	Shutter is closed.
	Orange	On screen muting

**KEY LOCK Indicator**

Indicator display		Projector status
Off		[CONTROL PANEL LOCK] [OFF]
Lit	Orange	[CONTROL PANEL LOCK] [ON]

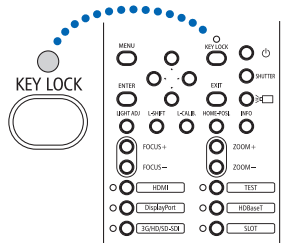

**REAR LED**

When [REAR LED] under [NOTIFICATION SETTINGS] is set to [ON], the operation is as shown below. When set to [OFF], the rear LED is always off.

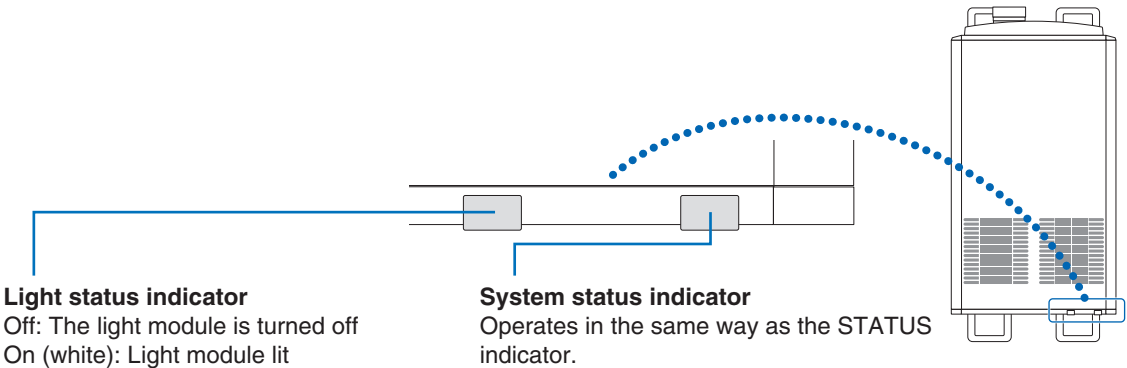

### **If the temperature protector is activated**

If the projector's internal temperature rises abnormally, the light module turns off and the temperature indicator flashes. It may happen that the projector's temperature protector is simultaneously activated and the projector's power turns off. If this happens, do the following:

- Unplug the power cable from the power outlet.
- If using in a place where the surrounding temperature is high, move the projector to a different, cool place.
- If there is dust in the ventilation holes, clean. (→ page [93](#), [94](#))
- Wait as such about 1 hour for the projector's internal temperature to lower.



## 7-3. Pin assignments and signal names of main terminals

### HDMI1/2 IN Terminal (Type A)

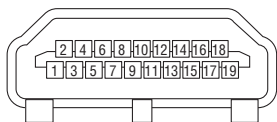

Pin No.	Signal	Pin No.	Signal
1	TMDS Data 2+	11	TMDS Clock Shield
2	TMDS Data 2 Shield	12	TMDS Clock-
3	TMDS Data 2-	13	CEC
4	TMDS Data 1+	14	Disconnection
5	TMDS Data 1 Shield	15	SCL
6	TMDS Data 1-	16	SDA
7	TMDS Data 0+	17	DDC/CEC grounding
8	TMDS Data 0 Shield	18	+5 V power supply
9	TMDS Data 0-	19	Hot plug detection
10	TMDS Clock +		

### DisplayPort1/2 IN Terminal

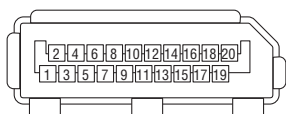

Pin No.	Signal	Pin No.	Signal
1	Main link lane 3-	11	Grounding 0
2	Grounding 3	12	Main link lane 0+
3	Main link lane 3+	13	Configuration 1
4	Main link lane 2-	14	Configuration 2
5	Grounding 2	15	Supplementary channel +
6	Main link lane 2+	16	Grounding 4
7	Main link lane 1-	17	Supplementary channel -
8	Grounding 1	18	Hot plug detection
9	Main link lane 1+	19	Return
10	Main link lane 0-	20	+3.3 V power supply

### HDBaseT Port (RJ-45)

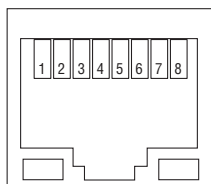

Pin No.	Signal
1	TxD+/HDBT0+
2	TxD-/HDBT0-
3	RxD+/HDBT1+
4	Disconnection/HDBT2+
5	Disconnection/HDBT2-
6	RxD-/HDBT1-
7	Disconnection/HDBT3+
8	Disconnection/HDBT3-

### USB Port (Type A)

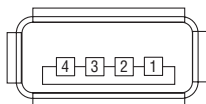

Pin No.	Signal
1	V <sub>BUS</sub>
2	D-
3	D+
4	Grounding

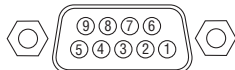
**RS-232C terminal (PC control) (D-Sub 9 Pin)**

Pin No.	Signal
1	Unused
2	Transmission data
3	Reception data
4	Connection/Pin 6
5	Grounding
6	Connection/Pin 4
7	Unused
8	Unused
9	Unused

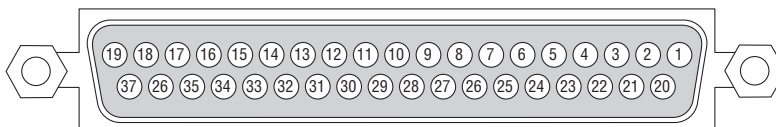
**GP I/O terminal (External control) (D-sub 37 pin)**

Pin No.	Signal Name	I/O
1	reserved	IN
2	reserved	IN
3	reserved	
4	reserved	
5	EXT_GPIN1+ (Control)	IN
6	EXT_GPIN2+ (Control)	IN
7	EXT_GPIN3+ (Control)	IN
8	EXT_GPIN4+ (Control)	IN
9	GPOUT1+ (External 3D L/R Output Reference +)	OUT
10	reserved	OUT
11	reserved	OUT
12	reserved	OUT
13	reserved	OUT
14	reserved	OUT
15	reserved	OUT
16	reserved	OUT
17	NC (not connected)	—
18	GND	PWR
19	GND	PWR

Pin No.	Signal Name	I/O
20	reserved	IN
21	reserved	IN
22	reserved	IN
23	reserved	IN
24	EXT_GPIN1- (Control)	IN
25	EXT_GPIN2- (Control)	IN
26	EXT_GPIN3- (Control)	IN
27	EXT_GPIN4- (Control)	IN
28	GPOUT1- (External 3D L/R Output Reference -)	OUT
29	reserved	OUT
30	reserved	OUT
31	reserved	OUT
32	reserved	OUT
33	reserved	OUT
34	reserved	OUT
35	reserved	OUT
36	NC (not connected)	—
37	GND	PWR

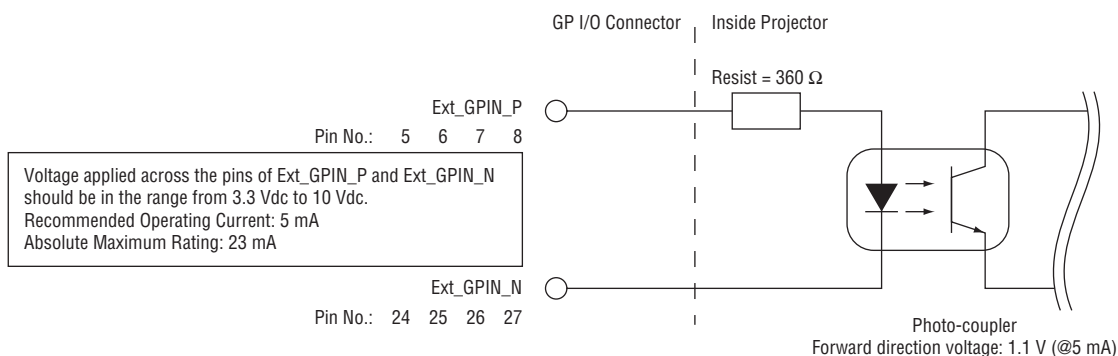

## Using GPIO Control

Momentary “ON” pulse enables you to control projector. To enable “ON” pulse, hold it for at least 300 ms. Hold “OFF” for at least 300 ms before “ON”.

Here is function list to control projector by using GPIO port.

Photo-coupler ON/OFF				Function
8-27	7-26	6-25	5-24	The following functions apply depending on the combination of input terminals.
OFF	OFF	OFF	ON	Power ON
OFF	OFF	ON	OFF	Power OFF
OFF	OFF	ON	ON	Shutter CLOSE
OFF	ON	OFF	OFF	Shutter OPEN
OFF	ON	OFF	ON	Select HDMI1
OFF	ON	ON	OFF	Select DisplayPort1
OFF	ON	ON	ON	Select SDI1
ON	OFF	OFF	OFF	Select SDI2
ON	OFF	OFF	ON	Select SDI3
ON	OFF	ON	OFF	Select SDI4
ON	OFF	ON	ON	Select HDBaseT
ON	ON	OFF	OFF	Select SLOT
ON	ON	OFF	ON	Select HDMI2
ON	ON	ON	OFF	Select DisplayPort2
ON	ON	ON	ON	reserved

Example for setting the shutter to CLOSE: Input ON to 6-25 and 5-24 while 8-27 and 7-26 are OFF.

### NOTE:

- The operation command coming from GPI/O port will be canceled when the projector is processing other tasks.
- Set all other pins than those in use to “OFF”.
- The operation command is executed upon continuous input of the “ON” pulse for approximately 300 ms.

Timing chart of GPIO control

Example of Select HDMI1

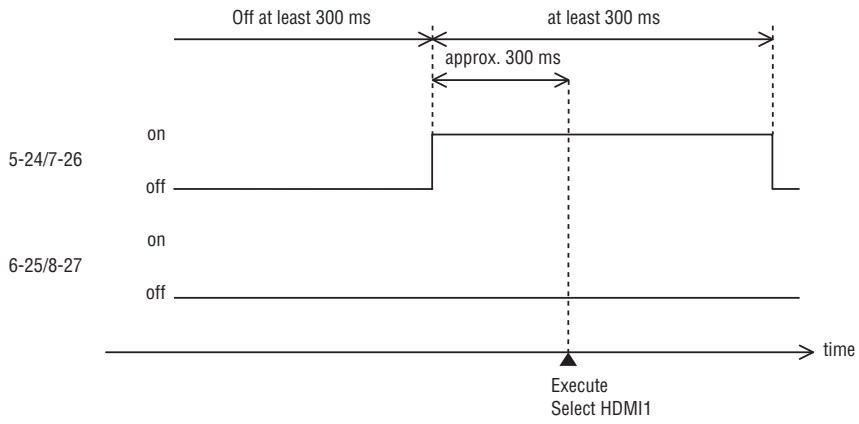

**3D terminal (D-sub 15 pin)**

This is used to connect a 3D image system to the projector.

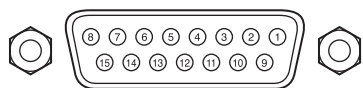

Pin view of a female connector

Pin No.	Signal Name	I/O	Function
1	+12V	PWR	Supplies power (+12V) to the 3D image system
2	GNDC	GND	Ground
3	GNDC	GND	Ground
4	RS232_RX	IN	Data transmission from the 3D image system (1200 Baud, 8 bits, No Parity)
5	RS232_TX	OUT	Data transmission to the 3D image system (1200 Baud, 8 bits, No Parity)
6	CONN_3D_MODE+	OUT	3D mode status (+) (Connects to the collector of the output transistor of the photo coupler inside the projector)
7	CONN_SYNC+	OUT	3D L/R switching timing signal (+) (Connects to the collector of the output transistor of the photo coupler inside the projector)
8	3D_INPUT_REFER- ENCE+	IN	3D L/R timing signal (+) (Connects to the anode of the input diode of the photo coupler inside the projector)
9	+12V	PWR	Supplies power (+12V) to the 3D image system
10	3D_INPUT_REFER- ENCE-	IN	3D L/R timing signal (-) (Connects to the cathode of the input diode of the photo coupler inside the projector)
11	3D_DISPLAY_REFER- ENCE+	IN	3D L/R display timing signal (+) (Connects to the anode of the input diode of the photo coupler inside the projector)
12	3D_DISPLAY_REFER- ENCE-	IN	3D L/R display timing signal (-) (Connects to the cathode of the input diode of the photo coupler inside the projector)
13	CONN_3D_MODE-	OUT	3D mode status (-) (Connects to the emitter of the output transistor of the photo coupler inside the projector)
14	CONN_SYNC-	OUT	3D L/R switching timing signal (-) (Connects to the emitter of the output transistor of the photo coupler inside the projector)
15	N/C	-	Unused

## 7-4. Remote Interlock Connector

This connector functions as safety device for the projector. The contacts are normally closed. When an abnormality occurs, the contacts open to immediately stop the projector (interlock state) (shipped with a shorting wire installed). By replacing the shorting wire with wiring and attaching it to the contacts, the projector can be immediately stopped remotely when an abnormality occurs in the projector.

Follow the following procedure to recover from the interlock state.

1. *Disconnect the AC power supply to the projector body.*
2. *Remove the plate inlet or side panel (page 17, 31).*
3. *Connect the contacts to the remote interlock connector and attach the plate inlet or side panel.*
4. *Connect the AC power supply to the projector body.*

### Remote interlock connector (exterior view)

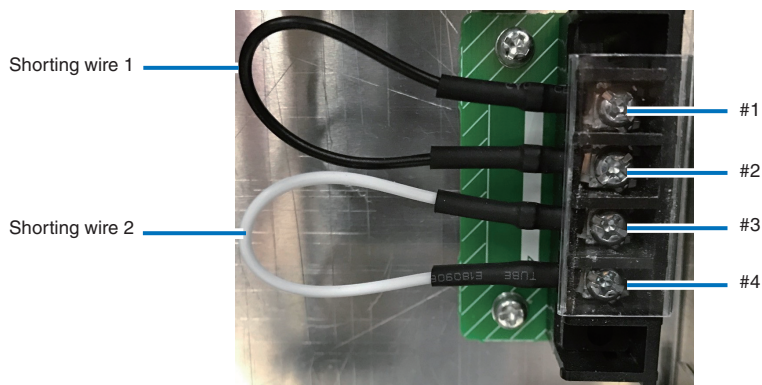

- The remote interlock terminal is equipped on inside of the side cover. Remove the plate inlet or side panel for connection.
- Securely reinstall the plate inlet or side panel.

## Circuit diagram

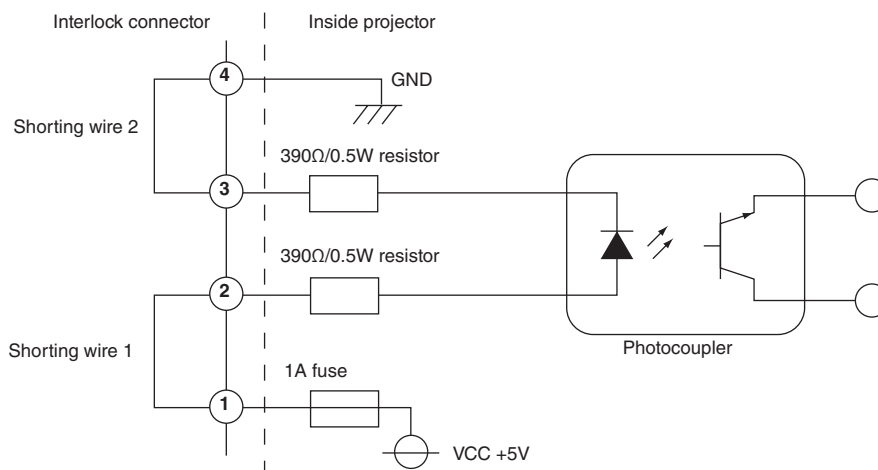

Connector no.	Photocoupler ON/OFF	Description
1	—	+5V supply
2	ON/OFF	Connects to the photocoupler anode inside the projector
3		Connects to the photocoupler cathode inside the projector
4	—	Ground

**When the length of the wiring is less than 5 m (approximate)**

Remove shorting wire 1 or shorting wire 2 and connect the external contacts (switch) to the projector interlock terminal (1 and 2 or 3 and 4) by cable.

- The projector operates normally when the contacts are closed and the system shuts off when the contacts are open.
- A power supply external from the projector is not necessary.
- A maximum of 2 sets of external contacts can be connected. If you are only using a single set of external contacts, connecting the shorting wire to the interlock terminal you are not using.
- The minimum rating required of the external contacts is 2mA.

**When the length of the wiring is at least 5 m (approximate)**

Remove shorting wire 1 and shorting wire 2 and connect the external device to the projector interlock terminals (2 and 3) (do not use 1 and 4).

- Connect terminal 2 to the positive side of the external device and connect terminal 3 to the negative side.
- The projector operates normally when a voltage in the range of DC5 to 16V is applied between terminals 2 and 3, and the system shuts off when the voltage is 0V.
- The minimum rated current required of the external device varies depending on the voltage applied between the terminals by the external device.
- When feeding the cable out from the projector, feed it so that it passes through the hole on the side face of the projector.

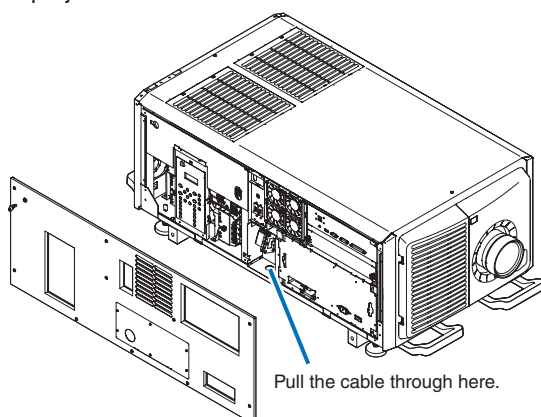

## 7-5. About the ASCII Control Command

This device supports the common ASCII Control Command for controlling our projector and monitor.

Please visit our web site for detailed information about the command.

[https://www.nec-display.com/dl/en/pj\\_manual/lineup.html](https://www.nec-display.com/dl/en/pj_manual/lineup.html)

### HOW TO CONNECT WITH AN EXTERNAL DEVICE

There are two methods to connect the projector with an external device such as a computer.

1. Connection thru the serial port.  
Connects the projector to a computer by a serial cable (straight cable).
2. Connection via network (LAN/HDBaseT)  
Connects the projector to a computer by a LAN cable.  
Concerning to the type of LAN cable, please ask to your network administrator.

### CONNECTION INTERFACE

1. Connection thru the serial port.

Communication Protocol

Item	Information
Baud rate	115200/38400/19200/9600/4800 bps
Data length	8 bits
Parity bit	No parity
Stop bit	1 bit
Flow control	None
Communications procedure	Full duplex

2. Connection via network

Communication Protocol (Connection via LAN)

Item	Information
Communication speed	Set automatically (10/100 Mbps)
Supported standard	IEEE802.3 (10BASE-T) IEEE802.3u (100BASE-TX, Auto-Negotiation)

Use the TCP port number 7142 for transmitting and receiving command.

Communication Protocol (Connection via HDBaseT)

Item	Information
Communication speed	100 Mbps
Supported standard	IEEE802.3u (100BASE-TX, Auto-Negotiation)

Use the TCP port number 7142 for transmitting and receiving command.



**PARAMETERS FOR THIS DEVICE****Input command**

Input terminal	Response	Parameter
HDMI1	hdmi1	hdmi1 or hdmi
HDMI2	hdmi2	hdmi2
DisplayPort1	displayport1	displayport1 or displayport
DisplayPort2	displayport2	displayport2
HDBaseT	hdbaset	hdbaset or hdbaset1
SDI1	sdi1	sdi1 or sdi
SDI2	sdi2	sdi2
SDI3	sdi3	sdi3
SDI4	sdi4	sdi4
SLOT	slot	slot or slot1

**Status command**

Response	Error Status
error:temp	Temperature error
error:fan	Fan trouble
error:light	Light source trouble
error:lens	Lens trouble
error:system	System trouble

# 7-6. Outline Drawing

Unit: mm (inch)

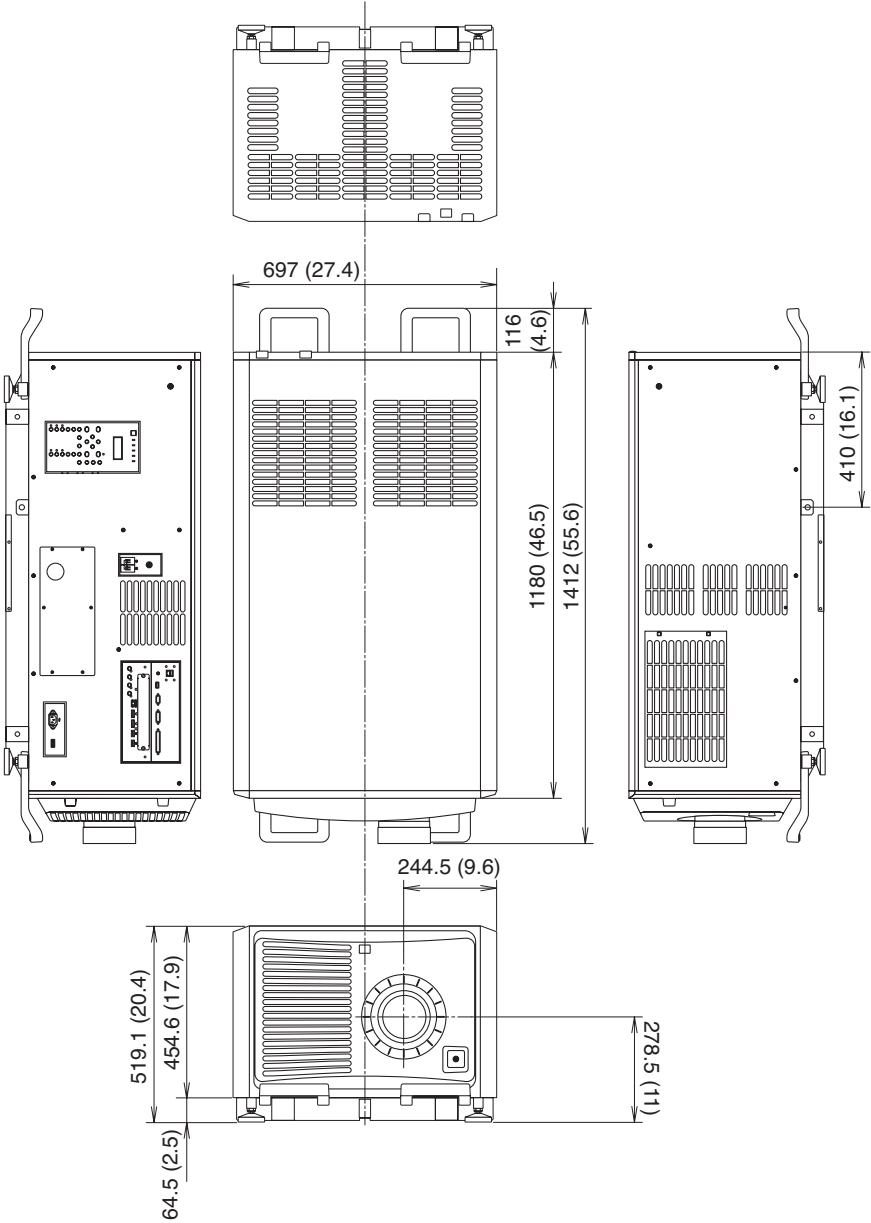

### 7-7. Special Installation

This projector can be installed in various ways, including on the floor.

**NOTE:**

- When turning the projector upside down during installation, use a soft cloth, etc., to protect the projector from scratches.
- When suspending or inclining the projector, check that all the filter covers are properly mounted. If not, the stoppers may come off during the installation procedure and the filter covers could fall.

#### 7-7-1. Installing the Projector on the Ceiling

To install the projector on the ceiling, install it by referring to the following specifications.

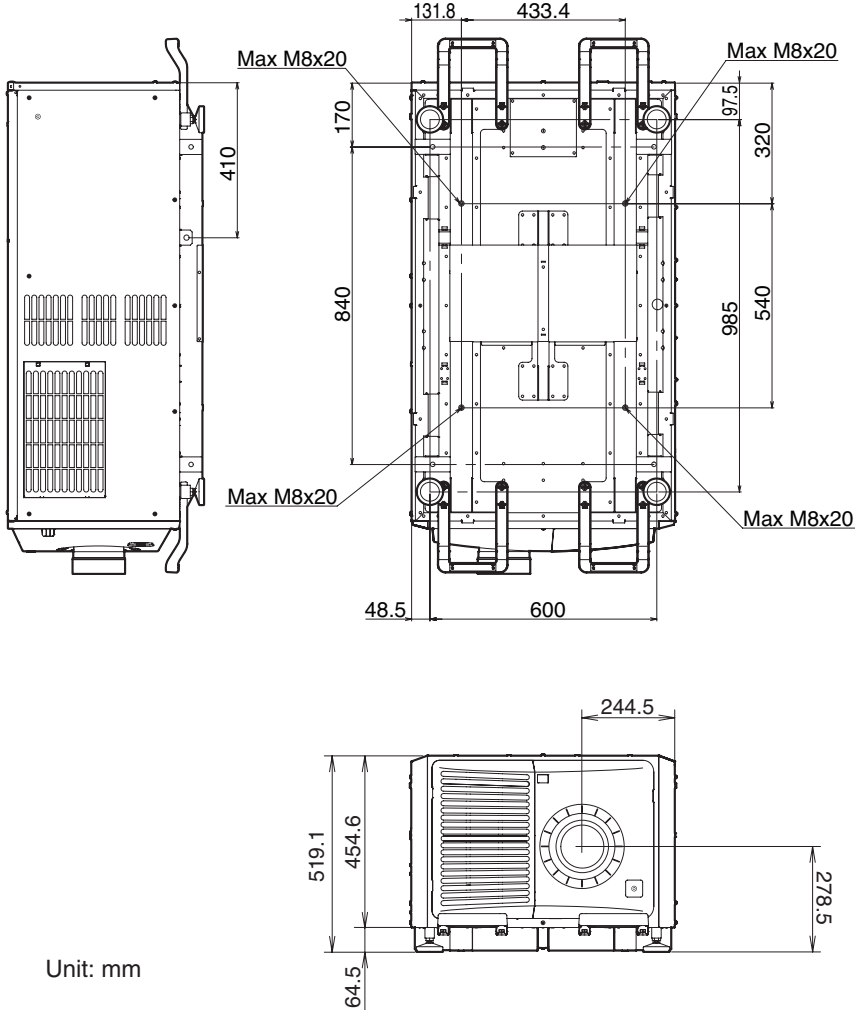

Unit: mm

### 7-7-2 Installing using eye bolts

Eye bolts can be used to lift and move the projector or to install it permanently suspended from the ceiling. Mount the eye bolts to the bottom or side surface of the blocks shown in the diagram below.

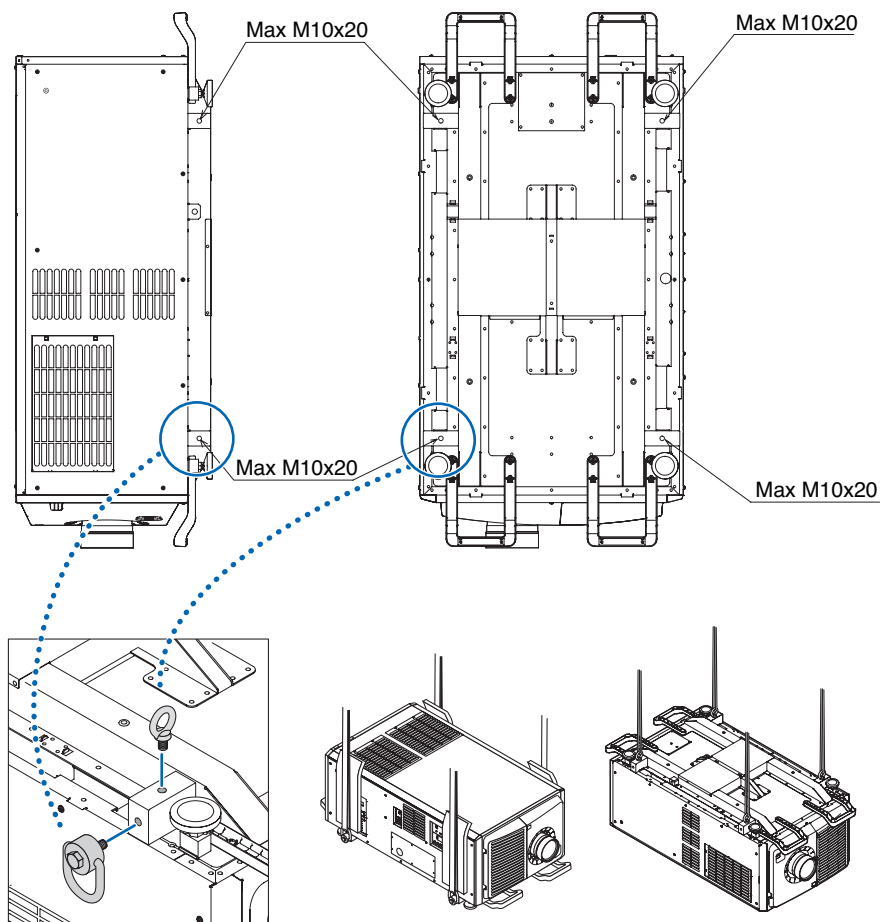

---

#### NOTE:

- *Cautions when using eye bolts*

*When mounting eye bolts on the side surface and suspending the projector from the side, be sure to use swivel eye bolts. Also, use a cushioning material over the wire in parts where it comes in contact with the projector to protect the projector from scratches.*

---

### 7-7-3. Installation for free tilting or portrait projecting

This projector can be set to any angle within a vertical 360° range. However, it cannot be installed with right or left slant.

If you install the projector vertically you can project screens from your computer and other sources in portrait orientation.

- Be sure to install the device with the side where the Connection terminals and Controls/Indicator Panel are located facing the top.
- Angle to display all the screens such as the on-screen menu can be changed by the menu [SETUP] → [MENU (2)] → [MENU ANGLE].

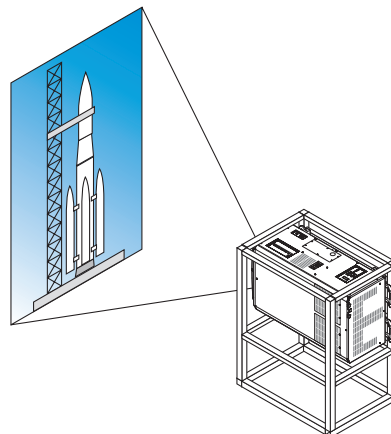

#### Precautions for the portrait installation

- Do not simply set the projector vertically on the floor or on a table. The projector may fall over, resulting in injury, damage, malfunction or hazardous laser radiation exposure. Also the intake vent may become blocked causing the unit's internal temperature to rise resulting in malfunction and risk of fire.
- For portrait installation the intake vents must be installed at the top and bottom. To ensure air flow to the bottom intake vent, a rack to support the unit is necessary. Please hire an installation service provider (for a fee) to make a custom portrait projection stand.
- When installed in portrait orientation the projector can be tilted forward or backward within a range of  $\pm 10^\circ$ . Tilting the projector forward or backward outside of this range, or tilting it to the left or to the right could cause it to malfunction.

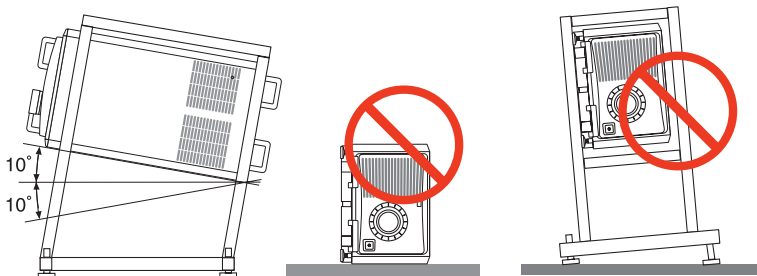

- To ensure air flow, maintain 60 cm/23.6" of space between the intake vent and the installation surface.

(NOTE) In the figure to the right there is plenty of space behind, above, and on either side of the projector unit.

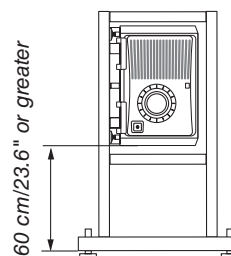

### ⚠ Caution to the installation for the Tilt-free projection

- Do not install the projector in the state of facing up/down or inclined directly on a floor and a table. If the projector falls down, It may cause of malfunction, damage, human injury or hazardous laser radiation exposure. If the intake vents are obstructed, the projector inside temperature will increase and it may cause of malfunction and fire.
- Make sure to produce the support metal for the projector as the ceiling mount metal. Please ask the service company about the support metal production. (for a fee)
- In case you need to install the projector in tilted angle, please install the projector by support metals that have enough durability to support the projector for a long time.

### Design and manufacturing conditions for a stand and a ceiling mount metal of the projector

Please hire an installation service provider (for a fee) to design and manufacture customized stand and ceiling mount metal. Please ensure that the design complies with the following conditions:

- There are intake openings and exhaust openings on the side of the main unit, exhaust openings on the rear, intake openings on the front, intake openings on the top side. Make sure that the design does not obstruct these openings. Also make sure to secure enough space to allow easy removal of the filter cover for cleaning the filter.
- Remove the level adjusters or the projector handles in case these hit against the stand. For removing the level adjuster, rotate the level adjuster itself, and for removing the handle, remove the handle fastening screws.
- Fix the stand onto the ceiling mount screw holes (4 positions) on the projector bottom face.

Dimensions of screw hole: for M8 screw Maximum depth 20 mm (Calculate the bolt length depending on the stand design)

- Horizontal adjustment mechanism (for example, bolts and nuts in 4 places)
- Make sure to design the stand not falling over easily.
- Make sure if the projector is fixed on the surface that has enough durability to stand the whole projector weight (the projector weight including LV unit 170 kg plus the lens weight 9 kg, i.e., 179 kg in total) for a long time.

### Referential drawings for the portrait projection

\* Figure illustrating the dimensions and conditions (not actual design blueprint).

(Unit: mm)

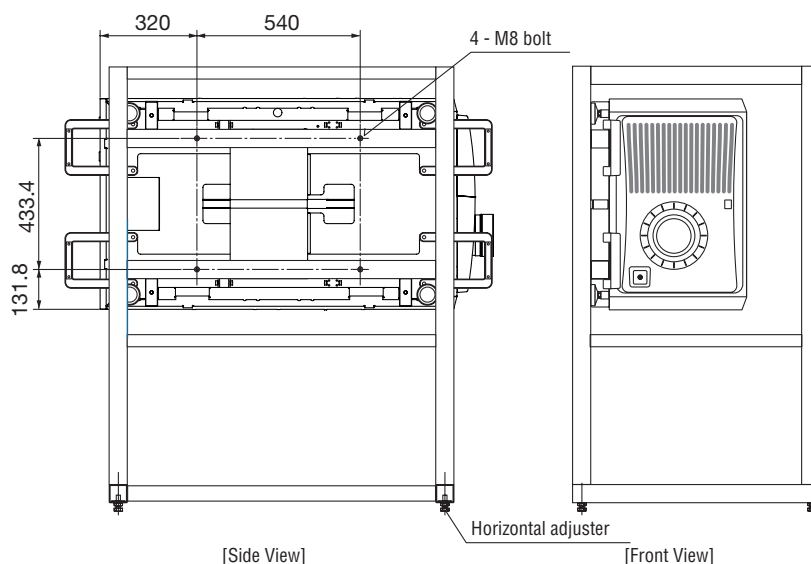

### ⚠ CAUTION

- To carry the projector, a minimum of six persons are required. Be sure to firmly grip the front and back handles, then move the projector.

### 7-7-4. Multi-Screen Projection

You can project two or four sources of images from the single projector at the same time. Another way is to use two or more projectors aligned for displaying a larger image with a higher resolution.

For information on each setting up procedures, see the user's manual.

#### [Note on Setting Up Two or More Projectors Aligned]

- Leave sufficient space on the left and right of the projector so that the intake and exhaust vents of the projector are not obstructed. When the intake and exhaust vents are obstructed, the temperature inside the projector will rise and this may result in a malfunction.

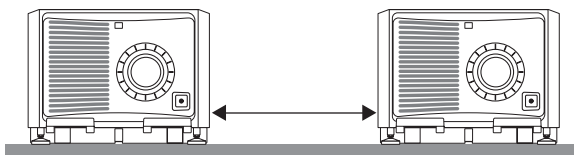

- Please do not pile up the projectors directly on top of one another when installing them. When the projectors are piled up on top of one another, they may fall down, resulting in damage and failure. The following installation is recommended when combining the installation of two projectors. Please leave sufficient space on the left and right of the projector.

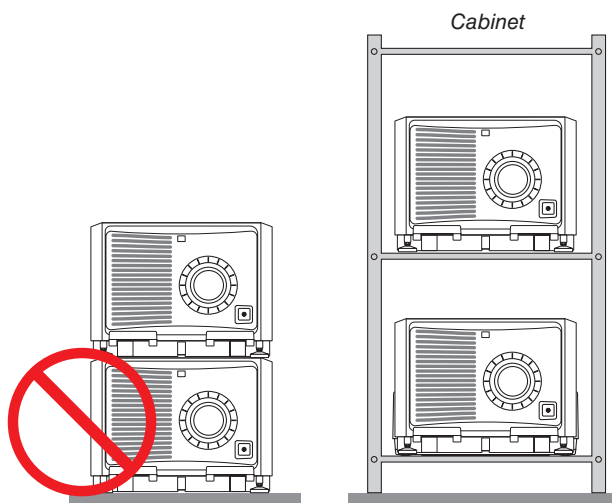

#### WARNING

Please request the retail store for special installation services such as when mounting the projector to the ceiling or suspending from the ceiling using eye bolts. Never carry out the installation by yourself. The projector may fall down and result in injury. Please use a sturdy cabinet that can withstand the weight of the projector for the installation. Please do not pile up the projectors directly on top of one another.

#### NOTE:

- For the range of the projection distance, please refer to the Appendix "Throw distance and screen size". (→ page 6)

## 7-8. Using the DCC's functions

### 7-8-1. Description of the Sections in the screen

You can change the size of the window display by dragging.

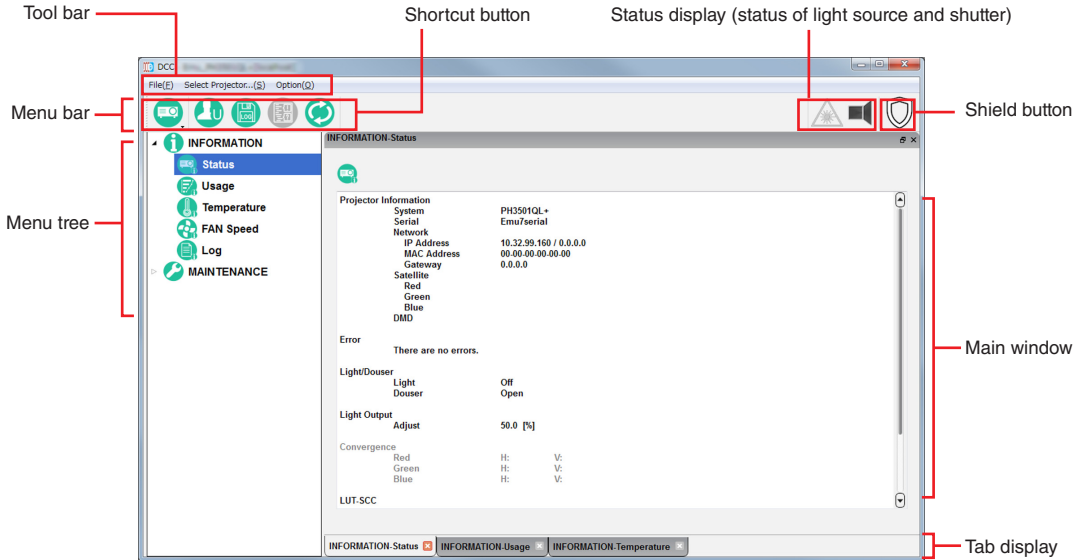

#### Tool bar

Menu	Submenu	Description
File	About DCC	Displays the version information of the DCC.
	Exit	Terminates DCC.
Select Projector...	Displays the Projector Select screen. (See page 55)	
Option	Always on Top	Select whether the DCC screen is always displayed as the first screen. At activation, "Not display first" is selected. Not checked: The DCC screen is not displayed in the foreground. Checked: The DCC screen is always displayed in the foreground.
	Disp Local Time	Sets the date and time for when logs are displayed using DCC. Not checked: Uses universal coordinated time (UTC). Checked: Uses the local time set in the projector main unit.
	Language	Select a language that is displayed on the menu.



**Menu bar**

The following menu buttons are displayed by default.

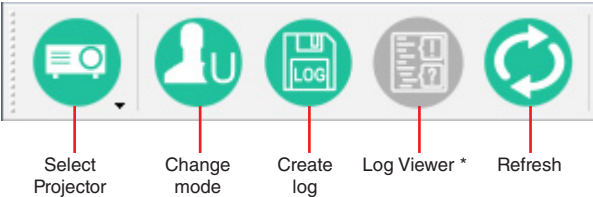

\* The function of Log Viewer is available on Service Mode only.

You can add menu buttons to the menu bar by dragging the menu buttons from the tree menu found on the left. To remove menu buttons that you have added, right-click on the menu button you want to remove, then click "Delete" menu.



**"Shield" button**

The DCC controls can be disabled by this button to prevent inadvertent operation (The "Shield" button is displayed in orange).

Press the "Shield" button again to return to the original state.

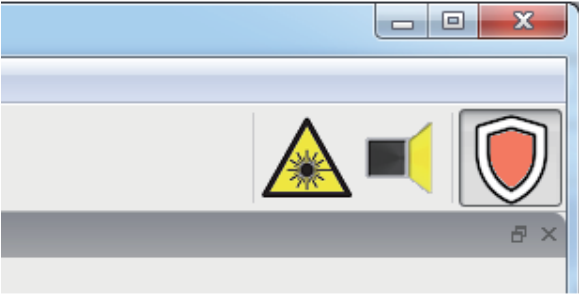

**Menu tree**

The menu selected here appears on the right part of the main window.

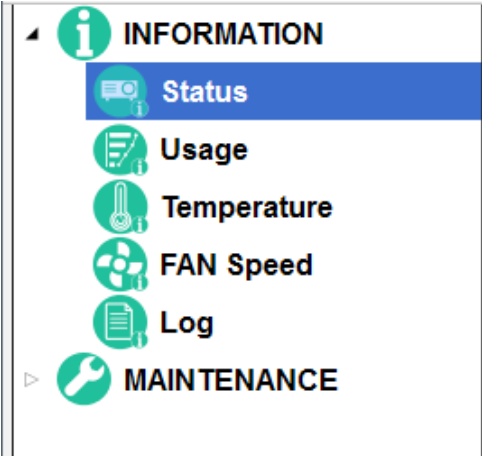

**Tab display**

The windows displayed on the main window appear as tabs at the bottom of the screen, and you can change the display by clicking on a tab. Click "x" to close a tab.

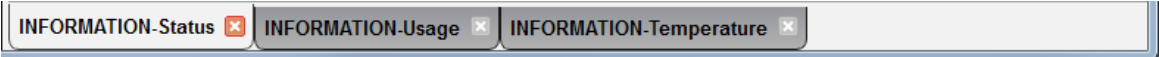

## Main window





The main window selected from the tree menu is displayed.

Multiple main windows can be displayed by dragging a tab out of the current window.

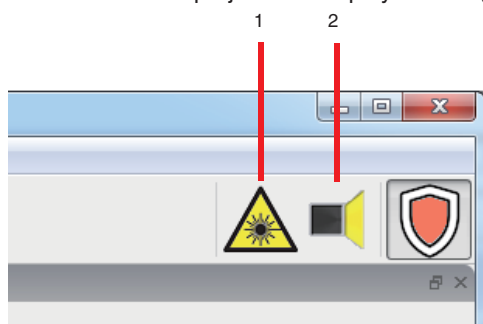
## Status display

The status of the projector is displayed through a number of icons.



1. Laser warning icon	Indicates whether the laser is illuminated or not (on or off).  (yellow): Laser light ON  (gray): Laser light OFF
2. Shutter icon	Displays the status of the shutter (open/closed).  (yellow): Shutter is open.  (gray): Shutter is closed.
3. Error Status Icon	Displays an error or warning. “Error” is displayed in red, and “Warning” is orange.

### 7-8-2. Switching the operating mode

There are two menu modes available. The menu items that can be used differ depending on the mode.

When you click “Change mode ” on the menu bar, you can switch the mode. Dedicated passcodes need to be entered in order to switch to Service mode.

Mode	Description
User mode	Menu for installation. (initial setting)
Service mode	Menu for the service personnel.

#### 1. Click the “Change mode ” button on the menu bar.

The “Control Mode” screen appears.

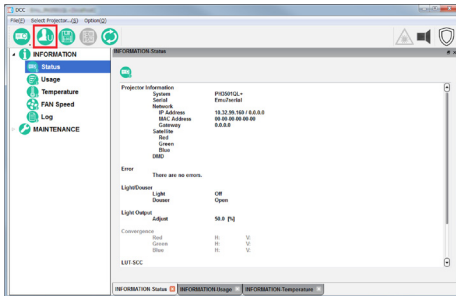

#### 2. Click the button of the mode to change.

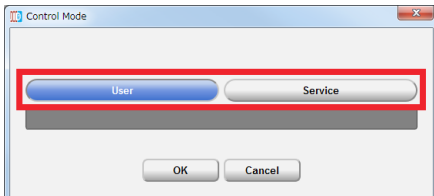

#### 3. Input the passcode and click “OK” button.

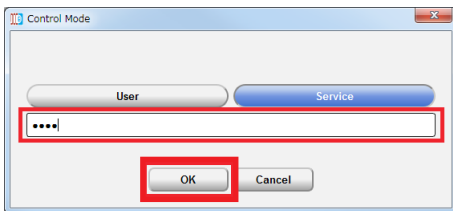

When changing to the User mode, you do not need to input the passcode is not needed.

#### NOTE:

- When you enter the password, pay enough attention to people around for the password abuse prevention. If you have anxiety the password is cheated, change the password immediately. Before entering the password, inspect the password entry device (PC) for any evidence of physical tampering. In the event that any suspicious markings are present, “DO NOT” enter the password and consult with the distributor. Always store the password and projector in a safe place and never divulge the password to unauthorized entities.

TIP:

- When the mode is changed, the “Change mode” button is displayed as shown below.
  - User mode
  - Service mode

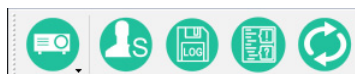
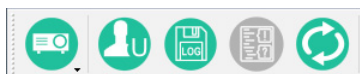

**7-8-3. Checking Information of the Projector and Logs**

Click one of the buttons under the “INFORMATION” on the tree menu to display the respective screens. The INFORMATION screen is made up of the following six screens that allow you to check information and various logs of the projector main unit.

- Status: ..... Allows you to check version information. You can also save the logs that are saved in the projector main unit onto a computer.
- Usage ..... Displays the usage times of the following: System/Light/Phosphor/Diffuser/Filter/Fan, etc.
- Temperature..... Displays the temperatures and atmospheric pressure of each part of the projector.
- FAN Speed ..... Display the fan speeds of each part of the projector, as well as the Phosphor/Diffuser speeds.
- Log ..... Allows you to check the status of the main projector unit and various logs.

## INFORMATION Screen (Status)

Click the "STATUS" button from the menu bar to go to the STATUS screen.  
 From the STATUS screen, you can check the Projector setting status.

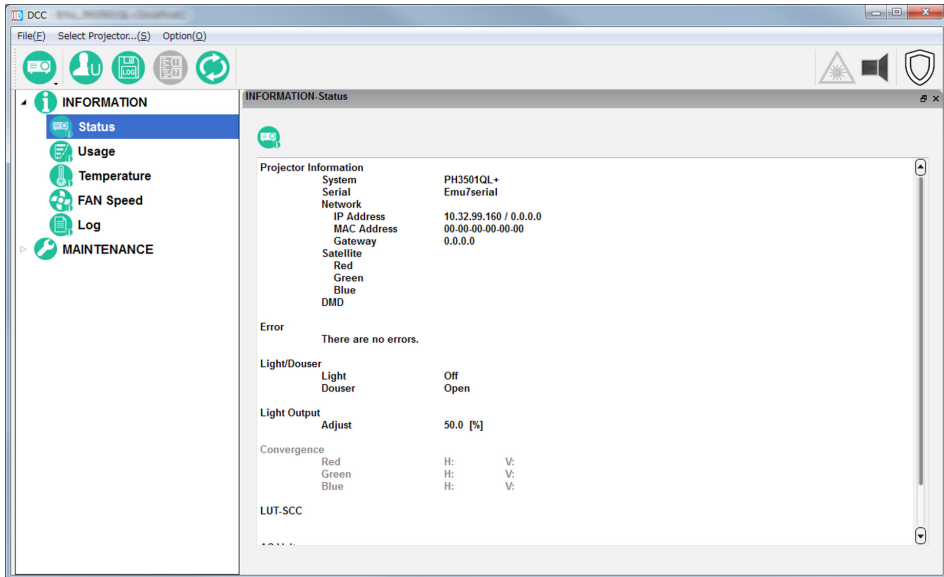

## INFORMATION Screen (Usage)

Click the “Usage” button on the tree menu to display the INFORMATION-Usage screen.

This screen allows you to check the usage times of the main projector unit, cooling fan, light source, phosphor, and diffuser, as well as other information such as the air filter usage time and the number of times the light source has been turned on.

The screenshot shows the DCC software interface. On the left is a tree menu with categories: INFORMATION (Status, Usage, Temperature, FAN Speed, Log), and MAINTENANCE. The 'Usage' option is selected. The main window displays a table titled 'INFORMATION Usage' with the following data:

	Usage	Warning	Strike
System(Power On)	1 [H]		
System(AC On)	2 [H]		
Light 1(SN1_12345)	3 [H]		2 [times]
Light 1[low]	93 [H]		
Light 2(LSNQ 73000001)	96 [H]		2 [times]
Light 2[low]	94 [H]		
Phosphor Wheel1	5 [H]		
Phosphor Wheel2	89 [H]		
Diffuser Motor1	6 [H]		
Diffuser Motor2	54 [H]		
Filter	92 [H]	0 [H]	
Douser Count	1		



## INFORMATION Screen (Temperature)

Click the “Temperature” button on the tree menu to display the INFORMATION-Temperature screen. This screen displays the temperatures and atmospheric pressure of each internal part of the projector.

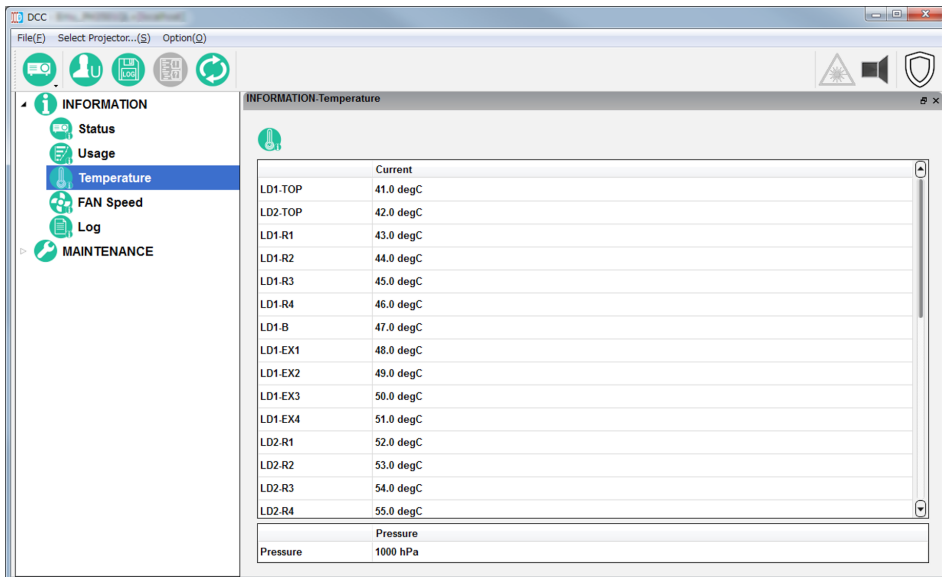

The screenshot shows the DCC software interface. The left sidebar contains a tree menu with the following items: INFORMATION (expanded), Status, Usage, Temperature (selected), FAN Speed, Log, and MAINTENANCE. The main display area is titled "INFORMATION-Temperature" and contains a table with the following data:

	Current
LD1-TOP	41.0 degC
LD2-TOP	42.0 degC
LD1-R1	43.0 degC
LD1-R2	44.0 degC
LD1-R3	45.0 degC
LD1-R4	46.0 degC
LD1-B	47.0 degC
LD1-EX1	48.0 degC
LD1-EX2	49.0 degC
LD1-EX3	50.0 degC
LD1-EX4	51.0 degC
LD2-R1	52.0 degC
LD2-R2	53.0 degC
LD2-R3	54.0 degC
LD2-R4	55.0 degC
Pressure	
Pressure	1000 hPa

## INFORMATION Screen (FAN Speed)

Click the “FAN Speed” button on the tree menu to display the INFORMATION-FAN Speed screen. This screen displays the fan speeds of each part of the projector, as well as the Phosphor/Diffuser speeds.

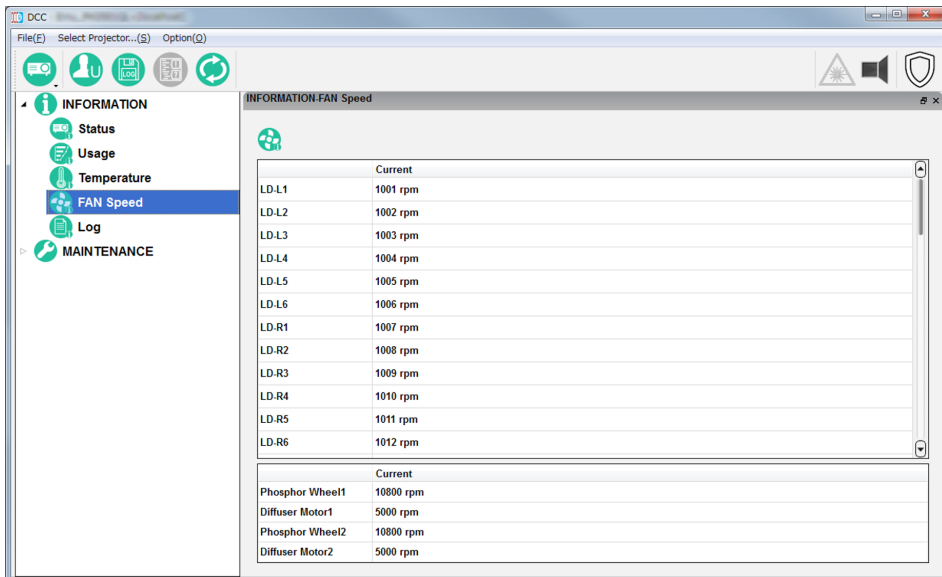

The screenshot shows the DCC software interface. The left sidebar contains a tree menu with the following items: INFORMATION (expanded), Status, Usage, Temperature, FAN Speed (selected), Log, and MAINTENANCE. The main area displays the INFORMATION-FAN Speed screen, which contains a table of fan speeds for various components.

	Current
LD-L1	1001 rpm
LD-L2	1002 rpm
LD-L3	1003 rpm
LD-L4	1004 rpm
LD-L5	1005 rpm
LD-L6	1006 rpm
LD-R1	1007 rpm
LD-R2	1008 rpm
LD-R3	1009 rpm
LD-R4	1010 rpm
LD-R5	1011 rpm
LD-R6	1012 rpm
Current	
Phosphor Wheel1	10800 rpm
Diffuser Motor1	5000 rpm
Phosphor Wheel2	10800 rpm
Diffuser Motor2	5000 rpm

## INFORMATION Screen (Log)

Click the “Log” button on the tree menu to display the INFORMATION-Log screen.  
You can check the various logs saved in the projector main unit from this screen.

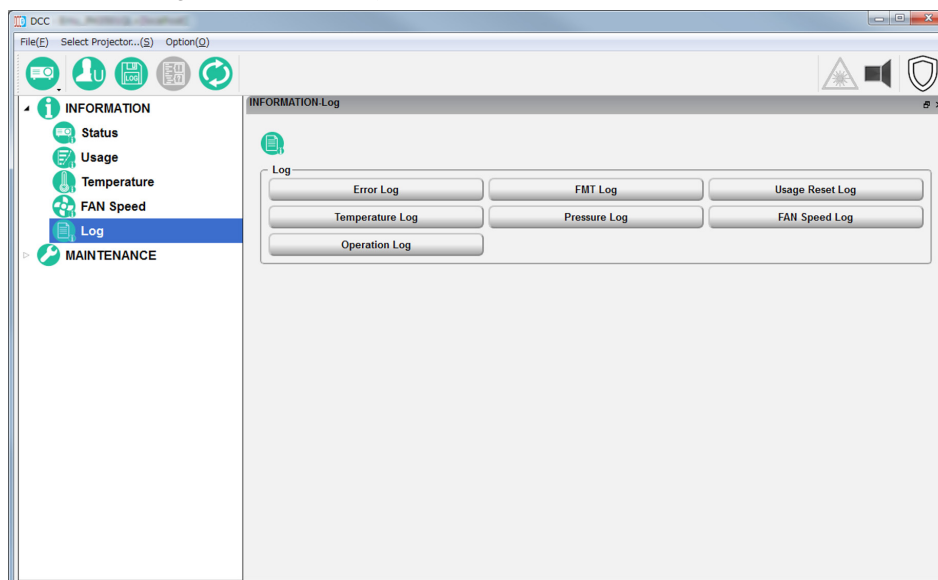

“Error Log” button	Displays the System Error Log screen.
“Usage Reset Log” button	Displays the User Reset Log screen. This displays various information about when the light source, fans, air filter, phosphor, and diffuser usage times were reset.
“Temperature Log” button	Displays the Temperature Log screen. This displays a record of the temperature from when the projector was turned on until it was turned off (peak hold).
[Pressure Log] button	Displays the Pressure Log screen. This displays a record of the atmospheric pressure from when the projector was turned on until it was turned off (peak hold).
“FAN Speed log” button	Displays the FAN Speed Log screen. This displays a record of the fan speed (minimum value) from when the power was turned on until it was turned off (peak hold).
“Operation Log” button	Displays the Operation Log screen. This displays a record of the operation of the projector.

## Log Filtering Function

Click the “Filter” button to display the Log Filter Setting screen. You can set the period of logs to display using this screen.

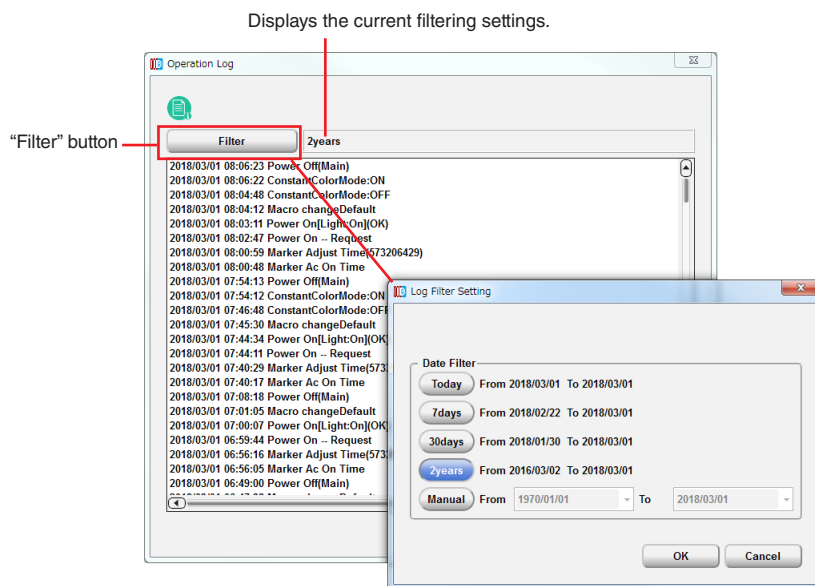

Today	Displays only the log for today.
7days	Displays the log for the last 7 days including today. (Default setting)
30days	Displays the log for the last 30 days including today.
2years	Displays the log for the last 2 years including today.
Manual	Displays the log for the specified period (from From to To). From: Selects the start date of the period for which to display the logs. To: Selects the end date of the period for which to display the logs. Click “Today” in the calendar to set to today’s date.
“OK” button	Displays the logs that match the specified conditions.
“Cancel” button	Cancels the settings and returns to the previous screen.

**System Error Log Screen**

This screen displays a log inside the projector main unit errors.

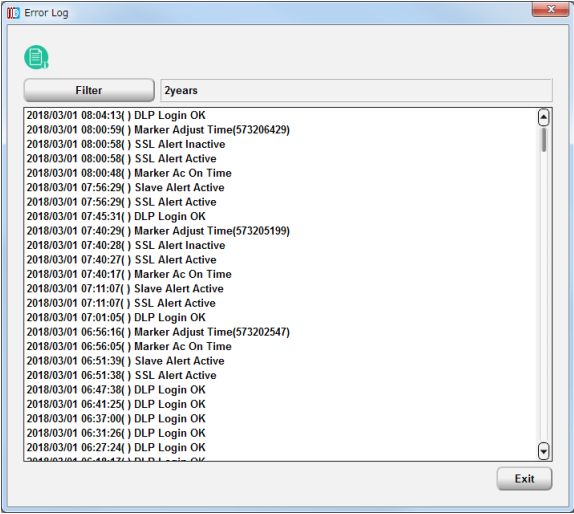

"Filter" button	Sets the period of the log to display.
"Exit" button	Returns to the previous screen.

## Usage Reset Log Screen

When the usage times for the following items are reset, the value immediately before the reset is saved as log information. This screen shows 64 items at most (64 items from the newest one are displayed).

- Light, Air filter, Fan, Phosphor, Diffuser

Date/Time	Reset	Usage	System(AC On)	System(Power On)	Light S/N
2018/02/26 02:46:12	Phosphor Wheel2	0[H]	0[H]	0[H]	
2018/02/26 02:46:12	Phosphor Wheel1	0[H]	0[H]	0[H]	
2018/02/26 02:46:12	Diffuser Motor2	0[H]	0[H]	0[H]	
2018/02/26 02:46:12	Diffuser Motor1	0[H]	0[H]	0[H]	
2018/02/26 02:46:12	System(AC On)	85[H]	86[H]	85[H]	
2018/02/26 02:46:12	System(Power On)	85[H]	86[H]	85[H]	
2018/02/26 02:46:12	Light 2(low)	0[H]	86[H]	85[H]	
2018/02/26 02:46:12	Light 1(low)	0[H]	86[H]	85[H]	
2018/02/26 02:46:12	Filter	0[H]	86[H]	85[H]	
2018/02/26 02:46:12	Light 2(low)	0[H]	86[H]	85[H]	
2018/02/26 02:46:12	Light Strike 2	0[times]	86[H]	85[H]	
2018/02/26 02:46:12	Phosphor Wheel2	0[H]	86[H]	85[H]	
2018/02/26 02:46:12	Diffuser Motor2	0[H]	86[H]	85[H]	
2018/02/26 02:46:11	Light 2	0[H]	86[H]	85[H]	LSNQ 74000009
2018/02/26 02:46:11	Light 1(low)	0[H]	86[H]	85[H]	
2018/02/26 02:46:11	Diffuser Motor1	0[H]	86[H]	85[H]	
2018/02/26 02:46:11	Phosphor Wheel1	0[H]	86[H]	85[H]	
2018/02/26 02:46:11	Light Strike 1	0[times]	86[H]	85[H]	
2018/02/26 02:46:11	Light 1	0[H]	86[H]	85[H]	LSNQ 74000010
2018/02/26 02:44:59	Phosphor Wheel2	0[H]	86[H]	85[H]	
2018/02/26 02:44:59	Diffuser Motor2	0[H]	86[H]	85[H]	
2018/02/26 02:44:59	Light 2(low)	0[H]	86[H]	85[H]	
2018/02/26 02:44:59	Light 2(low)	1[H]	86[H]	85[H]	

“Filter” Button	Sets the period of the log to display.
Data/Time	Displays the date and time.
Reset	Displays the reset subject.
Usage	Displays usage time prior to resetting.
System (AC On)	Displays the projector usage time (AC On) prior to resetting.
System (Power On)	Displays the projector usage time (Power On) prior to resetting.
“Clear” button	Clears the usage reset log and closes the screen.
“Refresh” button	Updates the displayed contents to the newest information.
“Exit” button	Returns to the previous screen.

**Temperature Log Screen**

This screen displays the maximum temperature recorded in the period from when the projector was turned on until it was turned off.

Displays the maximum temperatures measured and dates and times for each item from when the power was last turned on until now. The information that is saved in the log when the power is turned off is displayed in sequential order in the Temperature Log detail screen. When saved as a log, information at the time when the log was recorded (all temperatures, fan speeds, and light outputs within the projector) is also saved in addition to the maximum temperature and date and time of each item.

- Temperature Log detail screen

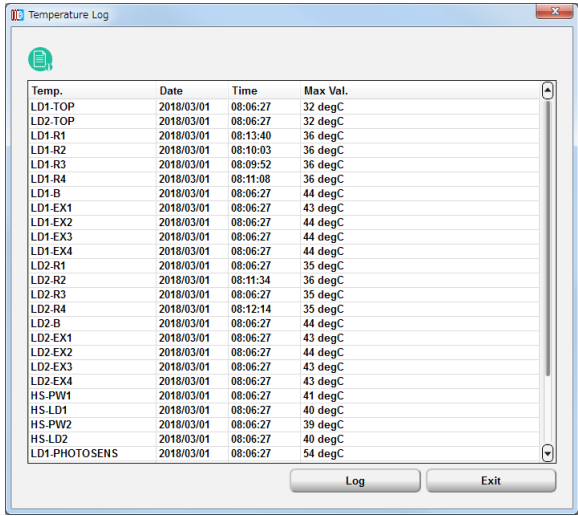

“Log” button	Displays previous logs.
--------------	-------------------------

**Pressure Log Screen**

This screen displays the maximum pressure recorded in the period from when the projector was turned on until it was turned off.

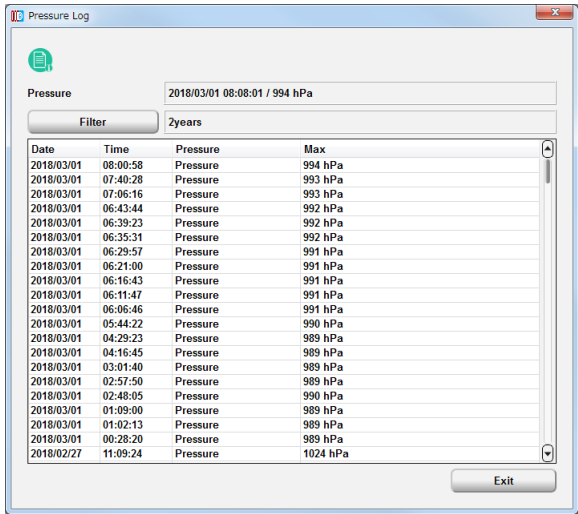

### FAN Speed Log Screen

This screen displays the minimum fan speeds recorded in the period from when the projector was turned on until it was turned off.

Displays the minimum fan speeds measured and dates and times for each item from when the power was last turned on until now. The information that is saved in the log when the power is turned off is displayed in sequential order in the Fan Speed Log detail screen.

- FAN Speed Log detail screen

Fan Type	Date	Time	Min
LD.L1	2018/03/01	08:08:13	0 rpm
LD.L2	2018/03/01	08:08:13	0 rpm
LD.L3	2018/03/01	08:08:13	0 rpm
LD.L4	2018/03/01	08:08:13	0 rpm
LD.L5	2018/03/01	08:08:13	0 rpm
LD.L6	2018/03/01	08:08:13	0 rpm
LD.R1	2018/03/01	08:08:13	0 rpm
LD.R2	2018/03/01	08:08:13	0 rpm
LD.R3	2018/03/01	08:08:13	0 rpm
LD.R4	2018/03/01	08:08:13	0 rpm
LD.R5	2018/03/01	08:08:13	0 rpm
LD.R6	2018/03/01	08:08:13	0 rpm
HRQL.S1	2018/03/01	08:08:13	0 rpm
HRQL.S2	2018/03/01	08:08:08	0 rpm
LS.L1	2018/03/01	08:08:13	0 rpm
LS.L2	2018/03/01	08:08:13	0 rpm
LS.L3	2018/03/01	08:08:13	0 rpm
LS.R1	2018/03/01	08:08:13	0 rpm
LS.R2	2018/03/01	08:08:13	0 rpm
LS.R3	2018/03/01	08:08:13	0 rpm
EX.R1	2018/03/01	08:08:18	4288 rpm
EX.R2	2018/03/01	08:08:13	4301 rpm
EX.S1	2018/03/01	08:08:29	4335 rpm
EX.R4	2018/03/01	08:08:03	4347 rpm
EX.L1	2018/03/01	08:08:03	1852 rpm

### Operation Log Screen

This screen displays a record of the operation of the projector.

Date	Time	Event
2018/03/01	08:06:23	Power Off(Main)
2018/03/01	08:06:23	ConstantColorMode-ON
2018/03/01	08:04:48	ConstantColorMode-OFF
2018/03/01	08:04:12	Macro changeDefault
2018/03/01	08:03:19	Power On(Light:On)(OK)
2018/03/01	08:02:47	Power On - Request
2018/03/01	08:00:59	Marker Adjust Time(573206429)
2018/03/01	08:00:48	Marker Ac On Time
2018/03/01	07:54:13	Power Off(Main)
2018/03/01	07:54:12	ConstantColorMode-ON
2018/03/01	07:46:48	ConstantColorMode-OFF
2018/03/01	07:45:30	Macro changeDefault
2018/03/01	07:44:34	Power On(Light:On)(OK)
2018/03/01	07:44:19	Power On - Request
2018/03/01	07:40:29	Marker Adjust Time(573205199)
2018/03/01	07:40:17	Marker Ac On Time
2018/03/01	07:00:18	Power Off(Main)
2018/03/01	07:01:05	Macro changeDefault
2018/03/01	07:00:07	Power On(Light:On)(OK)
2018/03/01	06:59:44	Power On - Request
2018/03/01	06:56:16	Marker Adjust Time(573202547)
2018/03/01	06:56:05	Marker Ac On Time
2018/03/01	06:49:09	Power Off(Main)

### 7-8-4. Creating logs

1. Click the "Create log" button on the menu bar.

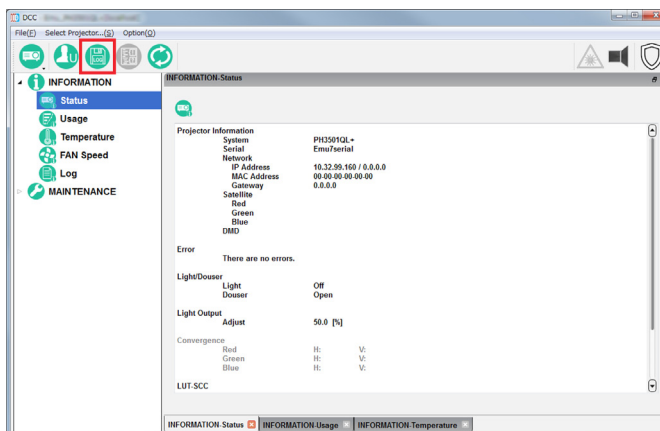



2. Select the log acquisition range and click the [OK] button.

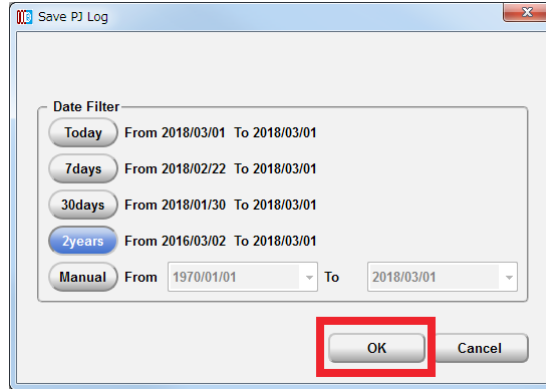

3. Select where to save the log and click the [Save] button.

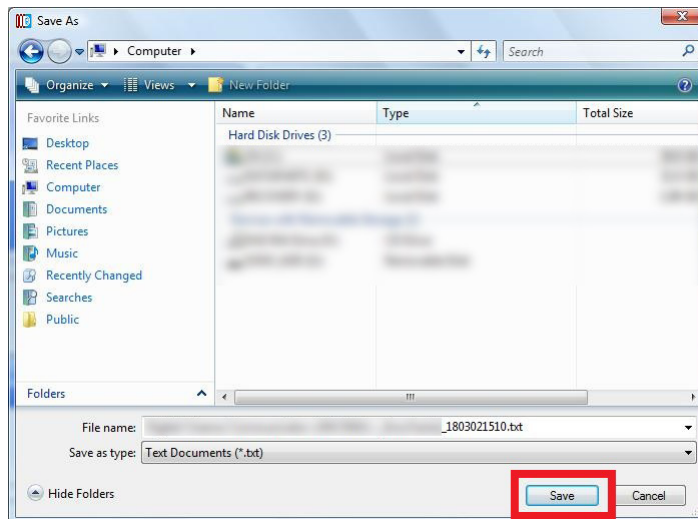

Log creation processing starts.

- The progress bar is displayed while the log is being created.
- Once the log has been created, the normal screen reappears.

**In Europe**

NEC Display Solutions Europe GmbH  
Address:  
Landshuter Allee 12-14  
D-80637 Munich, Germany  
Telephone: +49 89 99699 0  
Email: Infomail@nec-display.com

**In North and South America**

NEC Display Solutions of America, Inc.  
Address:  
500 Park Boulevard, Suite 1100,  
Itasca, Illinois 60143 U.S.A.  
Telephone: +1 800 836 0655  
Email: pjtechsupport@necdisplay.com

**In Oceania**

Australia, DrGroup Global  
Address:  
Unit 3, 277-281 Sir Donald Bradman Drive,  
DOWANDILLA SPA 5033  
CUSTOMER CALL CENTRE:  
Telephone: 1300 632 435  
Email: necsupport@thedrgroup.com.au

New Zealand, DrGroup ZN

Address:  
28 Walls Road, Penrose,  
Auckland, New Zealand  
CUSTOMER CALL CENTRE:  
Telephone: 0508 855 911  
Email: necsupport@thedrgroup.co.nz

**In Asia**

NEC Display Solutions, Ltd.  
Address:  
686-1, Nishioi, Oi-Machi,  
Ashigarakami-Gun, Kanagawa 258-0117, Japan  
Telephone: +81 465 85 2369

NEC (China) Co., Ltd.

Address:  
6F, Landmark diplomatic office building D2,  
No. 19 East Road, Chaoyang District,  
Beijing 100600, R.P.C.  
Telephone: 010-59342706

NEC Hong Kong Ltd.

Address:  
25/F, The Metropolis Tower, 10 Metropolis Drive,  
Hunghom, Kowloon, Hong Kong  
Telephone: +852 2369 0335

NEC Taiwan Ltd.

Address:  
7F, No. 167, SEC. 2, Nan King East Road,  
Taipei, Taiwan, R.O.C.  
Telephone: +886 2 8500 1710

NEC Asia Pacific Pte. Ltd.

Address:  
80 Bendemeer Road,  
#05-01/02 Hyflux Innovation Centre,  
Singapore 339949  
Telephone: +65 6799 6188

NEC Corporation of Malaysia Sdn Bhd

Address:  
Suite 20-01, Level 20,  
The Gardens North Tower,  
Mid Valley City, Lingkaran Syed Putra,  
59200 Kuala Lumpur  
Telephone: +603-2299 6322