

PN-SR763M

Flat Panel Floor Cart

FOR SHARP® AQUOS BOARD MODELS
PN-L703A/703B AND PN-L603A/603B



Display size
50"-80"



Max load
225lb (102kg)

The PN-SR763M Flat Panel Floor Cart offers the most complete mobile solution for any large screen application. Designed for Sharp® displays, durable 4" swivel casters provide easy maneuverability over various flooring surfaces and through doorways. Two locking casters ensure complete stability wherever the cart is placed. In addition, the incremental tilt and continuous height adjustment assures the display will be positioned at the ideal viewing angle for the viewing audience.

The PN-SR763M's incremental tilt feature provides convenient display adjustments, so you can find the perfect viewing angle.



Additional Features

- ✓ Fits displays with mounting hole patterns up to 965 x 405mm (38.00"W x 15.94"H)
- ✓ Internal cable management for clean, clutter-free look
- ✓ Maneuvers easily on four 4.00" (102mm) swivel casters, two locking
- ✓ Comes standard with a six plug surge protector that provides convenient cable management on the back of the cart
- ✓ Compatible with WiPG-1500 Wireless Interactive Presentation Gateway



Cart with optional
PN-SR763M-ACC1
Accessory Shelf

SHARP®

www.sharppusa.com/aquosboard
1-800-BE-SHARP

PN-SR763M	Flat Panel Floor Cart for Sharp AQUOS Board Models PN-L703A/703B and PN-L603A/603B
------------------	--

Product Specifications

	DIMENSIONS (W x H x D)	PRODUCT WEIGHT	LOAD CAPACITY	FINISH	AVAILABLE COLORS
PN-SR763M	56.00" x 65.50" x 27.45" (1422 x 1664 x 697mm)	80lb (36.4kg)	225lb (102kg)	Powder Coat Matte	Black

Package Specifications

	PACKAGE SIZE (W x H x D)	PACKAGE SHIP WEIGHT	PACKAGE UPC CODE	PACKAGE CONTENTS	UNITS IN PACKAGE
PN-SR763M	57.75" x 19.25" x 7.75" (1467 x 489 x 197mm)	110lb (50kg)	735029301882	Cart, surge protector and mounting hardware	1

Accessories

PN-SR763M-ACC1: PC/Keyboard Accessory Shelf

All dimensions = inch (mm)

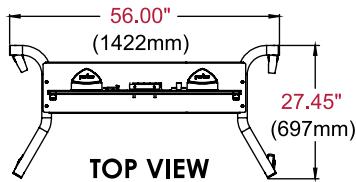
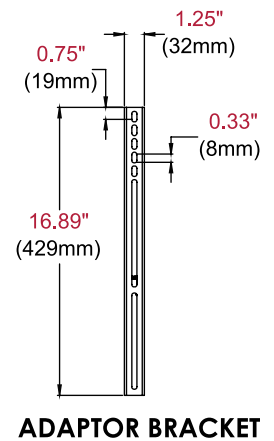
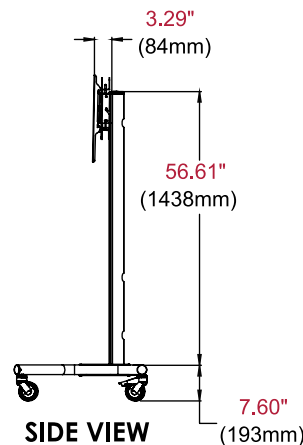
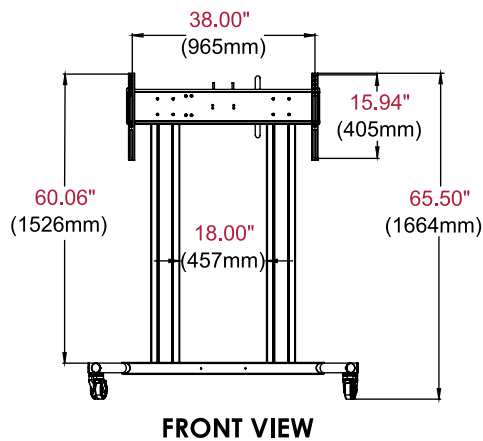
Architect Specifications

The Flat Panel Floor Cart shall be a Sharp model PN-SR763M and shall be located where indicated on the plans. Assembly and installation shall be done according to instructions provided by the manufacturer.

Visit peerless-av.com to see the complete line of AV solutions from Peerless-AV, including outdoor displays, wireless, kiosks, digital audio, display mounts, projector mounts, carts/stands, and a full assortment of accessories.

Peerless-AV
2300 White Oak Circle
Aurora, IL 60502 USA
(800) 865-2112
(630) 375-5100
Fax: (800) 359-6500

Peerless-AV Europe
Unit 3 Watford Interchange
Colonial Way, Watford
Herts, WD24 4WP
United Kingdom
+44 (0) 1923 200100
Fax: +44 (0) 1923 200101

Peerless-AV de México
Ave de las Industrias 413
Parque Industrial Escobedo
Escobedo, N.L.,
Mexico 66050
+52 (81) 8384-8300
Fax: +52 (81) 8384-8360

