

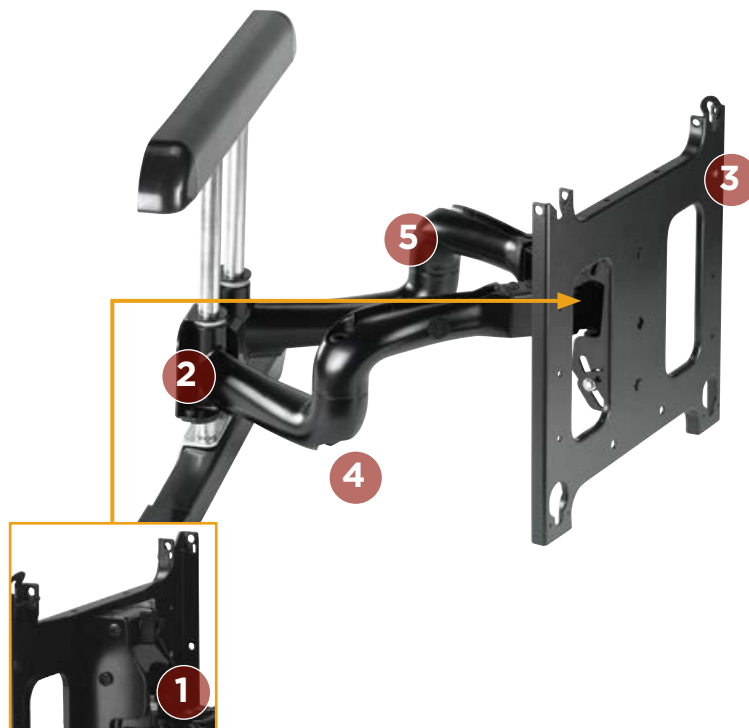

## FEATURES

- 1 CENTRIS® FINGERTIP TILT**  
Select the perfect tension for your screen's center of gravity to achieve smooth fingertip tilt. Screen angle stays set until you decide to readjust.
- 2 POST-INSTALLATION HEIGHT ADJUSTMENT**  
Adjust height up to 1" (25 mm) after mount is installed for ultimate flexibility.
- 3 CLICKCONNECT® LATCHING**  
Hear an audible click when the screen engages with the mount. Easy to connect/disconnect - no tools needed!
- 4 EXTENDS UP TO 256"**  
Extends up to 25" (635 mm) for viewing from any angle!
- 5 CABLETRAC™ SYSTEM**  
Channeled cable management provides quick and easy routing of cables.



## SPECIFICATIONS

Extension	25" (635 mm)
Tilt/Roll	-15°, +5° / ±2.5°
Height Adjustment	1" (25 mm)
Dimensions* (HxWxD)	22.04" x 27.06" x 3.5" (560 x 687 x 89 mm)
Color	Black, Silver
Weight Capacity	200 lbs (90.7 kg)

\* Dimensions do not include interface bracket

## WHAT YOU NEED TO KNOW

### ORDERING OPTIONS

Available in custom and universal.

- PNRU = Universal 42 - 71"
- PNRXXXX = Custom (see MountFinder Pro at [chiefmfg.com](http://chiefmfg.com))

# Touchboards

205 Westwood Ave, Long Branch, NJ 07740  
Phone: 866-94 BOARDS (26273) / (732)-222-1511  
Fax: (732)-222-7088 | E-mail: [sales@touchboards.com](mailto:sales@touchboards.com)

## TECHNICAL DRAWINGS

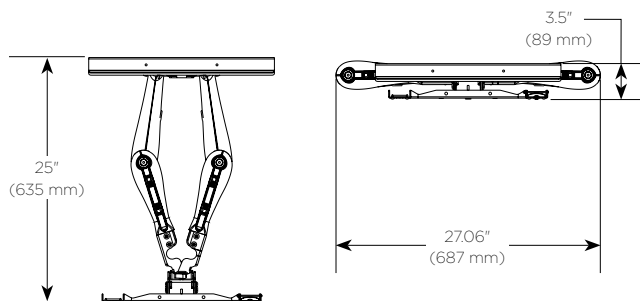

## RECOMMENDED ACCESSORIES



**PACCC1** ■ Center Channel Speaker Adapter



**PACLRI** ■ Left/Right Speaker Adapter



**PAC715** ■ VC Camera Shelf (above)

For a complete list of TV mount accessories see page 86.