

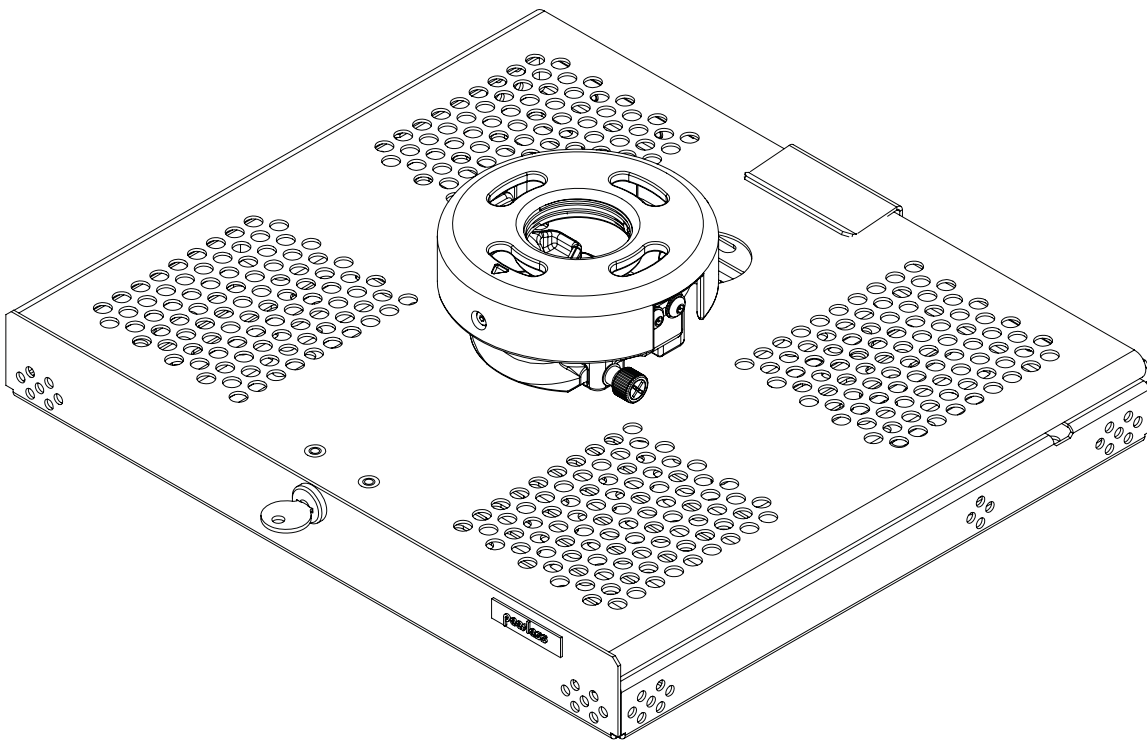

## Installation and Assembly: Tray Style Projector Mount

Models: PSMU-PRS, PSMU-PRS-S, PSMU-PRS-W



205 Westwood Ave, Long Branch, NJ 07740  
Phone: 866-94 BOARDS (26273) / (732)-222-1511  
Fax: (732)-222-7088 | E-mail: sales@touchboards.com

**Maximum Load Capacity: 30 lb (13.6 kg)**

**NOTE:** Read entire instruction sheet before you start installation and assembly.

## **WARNING**

- Do not begin to install your Peerless product until you have read and understood the instructions and warnings contained in this Installation Sheet. If you have any questions regarding any of the instructions or warnings, please call Peerless customer service at 1-800-865-2112.
- This product should only be installed by someone of good mechanical aptitude, has experience with basic building construction, and fully understands these instructions.
- Make sure that the supporting surface will safely support the combined load of the equipment and all attached hardware and components.
- Never exceed the Maximum Load Capacity of 30 lb (13.6 kg).
- If mounting to wood ceiling joists, make sure that mounting screws are anchored into the center of the joists. Use of an "edge to edge" stud finder is highly recommended.
- Always use an assistant or mechanical lifting equipment to safely lift and position equipment.
- Tighten screws firmly, but do not overtighten. Overtightening can damage the items, greatly reducing their holding power.

### **Accessories**

- Lightweight Adjustable Suspended Ceiling Kit (CMJ 500)
- Lightweight Suspended Ceiling Kit (CMJ 455)
- Accessory Pack for CMJ 455 (ACC 455)
- Lightweight Cathedral Ceiling Plate (ACC 912)
- Unistrut or Structural Ceiling Plates (CMJ 300, CMJ 310)
- Anti-Vibration Ceiling Plates (ACC 845)
- I-Beam Clamps (ACC 558, ACC 559)
- Truss Ceiling Adapter (ACC 557)
- Unistrut Adapter (ACC 550)
- Escutcheon Ring (ACC 640)
- Round Ceiling Plate (ACC 570)
- Cord Wrap (ACC 852, ACC 852W, ACC 852S)
- 3/4" Pipe Reducer (ACC 913)
- Fixed Length 1 1/2" Extension Columns (EXT models)
- Adjustable Length 1 1/2" Extension Columns (ADJ models)
- Extension Column Stabilizer Kit (ACC 050)
- Extension Column Connector (ACC 109)
- 1/2" Threaded Rod (ACC 820)
- Threaded Rod Adapter (ACC 810)

### **Tools Needed for Assembly**

- stud finder ("edge to edge" stud finder is recommended)
- phillips screwdriver
- drill with 5/16", 3/8", and 5/32" drill bits

**IMPORTANT!** Turn to the appropriate page for your ceiling installation.

#### **Installations:**

- To Wood Joist Finished Ceilings,  
Exposed Wood Joists, or Wood Beam Ceilings ..... page 5**
- To Concrete Ceilings ..... page 6**
- To Threaded Rod, or Extension Columns..... page 7**

#### **Projector Alignment:**

- Adjusting Roll Pitch and Yaw ..... page 11**

**IMPORTANT!** Read entire instruction sheet before you start installation and assembly.

Before you start check the parts list below to make sure all of the parts shown are included.

## Parts List

Description	Qty.	PSMU-PRS	PSMU-PRS-S	PSMU-PRS-W
A projector mount assembly	1	055-1963	055-4963	055-2963
B tray	1	055-0725	055-0725-S	055-0725-W
C lock plug	1	3022-502	3022-502	3022-502
D thumb screw	1	560-0106	560-0106	560-0106
E #10-32 X 3/8 serrated washer head socket pin screw	2	520-1151	520-2151	520-2151
F spacer	12	540-9416	540-9416	540-9416
G bushing	4	590-1116	590-1116	590-1116
H square nut	4	530-1022	530-1022	530-1022
I washer	4	540-1025	540-1025	540-1025
J 1/4 X 3/8 socket pin	4	520-1109	520-1109	520-1109
K M3 X 16mm serrated washer head socket pin screw	4	510-1083	510-1083	510-1083
L M3 X 25mm serrated washer head socket pin screw	4	510-1127	510-1127	510-1127
M M4 X 16mm serrated washer head socket pin screw	4	510-1087	510-1087	510-1087
N M4 X 25mm serrated washer head socket pin screw	4	510-1082	510-1082	510-1082
O M4 X 35mm serrated washer head socket pin screw	4	510-1097	510-1097	510-1097
P M5 X 16mm serrated washer head socket pin screw	4	510-1161	510-1161	510-1161
Q M5 X 25mm serrated washer head socket pin screw	4	510-1122	510-1122	510-1122
R M6 X 20mm serrated washer head socket pin screw	4	510-9554	510-9554	510-9554
S M6 X 30mm serrated washer head socket pin screw	4	510-1067	510-1067	510-1067
T 4 mm T-WRENCH	1	560-1718	560-1718	560-1718
U 2mm allen wrench	1	560-1097	560-1097	560-1097
V wood screw	2	5S1-015-C03	5S1-015-C04	5S1-015-C04
W concrete anchor	2	590-0320	590-0320	590-0320
X key	1	0000-322	0000-322	0000-322
Y #10-32 X 1/4" socket pin screw	1	520-1196	520-2196	520-2196
Z connection block	1	580-1065	580-4065	580-4065

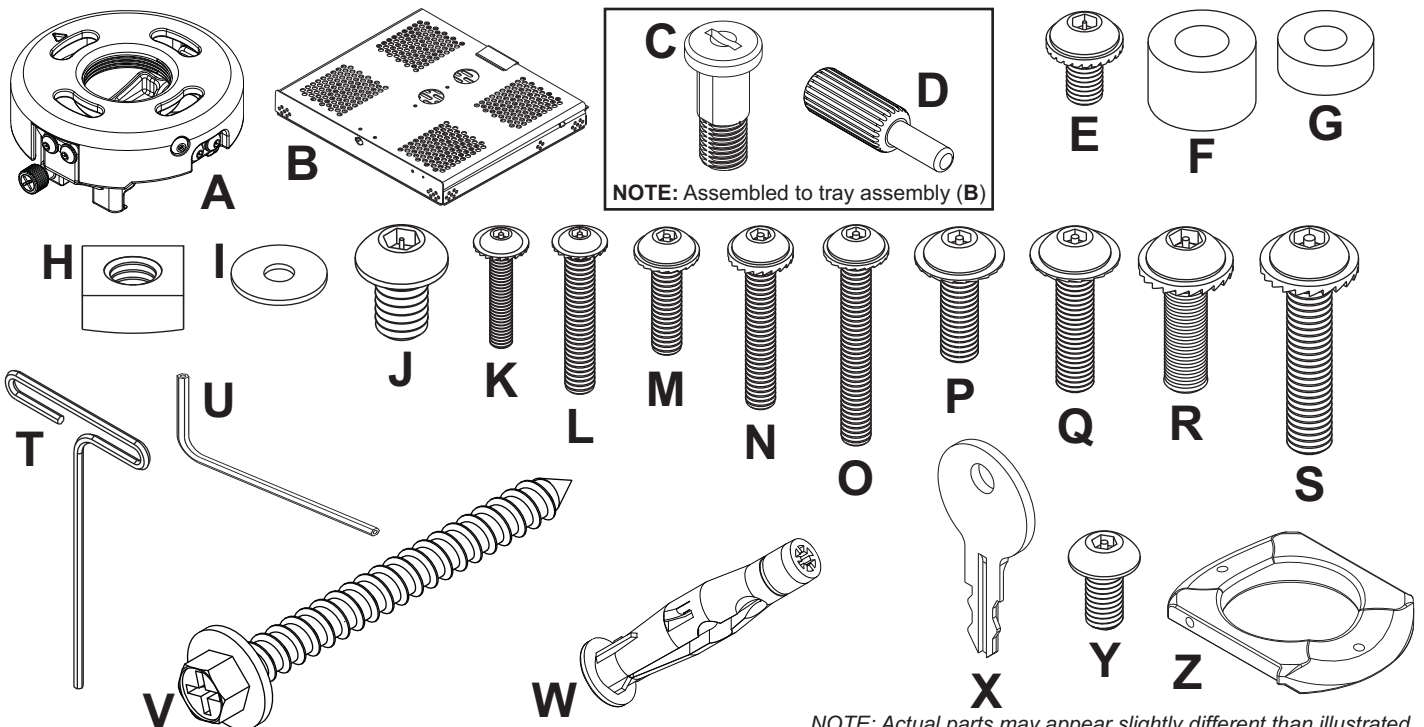

NOTE: Actual parts may appear slightly different than illustrated.

- 1** Remove the lock plug (C) by turning the key counterclockwise. Open the top cover and attach connection block (Z) to tray (B) using two #10-32 x 3/8" serrated washer head socket pin screws (E) as shown.

**NOTE:** Make sure that the connection block shoulder is facing the back of projector.

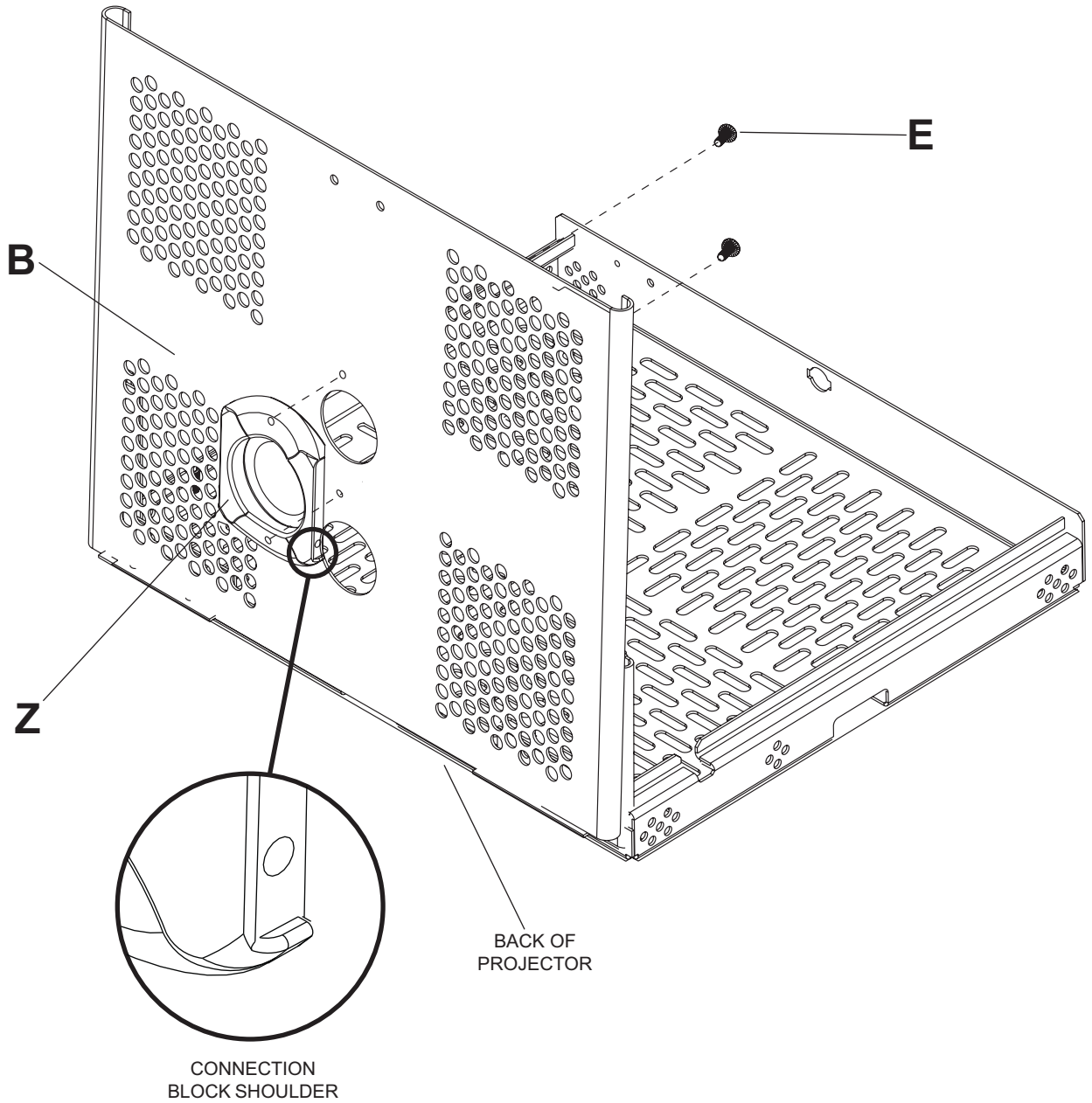

## Installation To Wood Joist Ceilings

### ⚠ WARNING

- Installer must verify that the supporting surface will safely support the combined load of the equipment and all attached hardware and components.
- Tighten wood screws so that projector mount assembly is firmly attached, but do not overtighten. Overtightening can damage the screws, greatly reducing their holding power.
- Never tighten in excess of 80 in. • lb (9 N.M.).
- Make sure that mounting screws are anchored into the center of the stud. The use of an "edge to edge" stud finder is highly recommended.
- Hardware provided is for attachment of mount through standard thickness drywall or plaster into wood studs. Installers are responsible to provide hardware for other types of mounting situations.

**2** Place projector mount assembly (**A**) on ceiling as a template and mark the center of the two mounting holes. Make sure that the mounting holes are in the center of the wood joist. Drill two 5/32" (4 mm) dia. holes to a minimum depth of 2.5" (64 mm). Attach projector mount assembly (**A**) with two #14 X 2.5" (6 mm x 64 mm) wood screws (**V**) and two flat washers (**I**) as shown in **figure 2.1** or **figure 2.2** depending on joist orientation.

**Note:** Mounting slots on projector mount assembly (**A**) allow for 30° (±15°) of swivel adjustment before fully securing wood screws (**V**).

Tighten wood screws (**V**) using 3/8" (10 mm) socket wrench until projector mount assembly (**A**) is firmly attached.

**Skip to step 6**

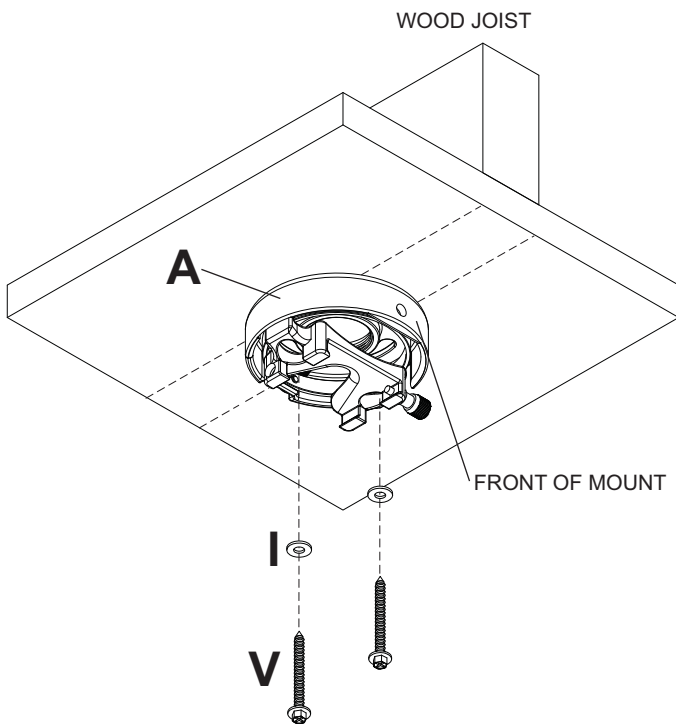

figure 2.1

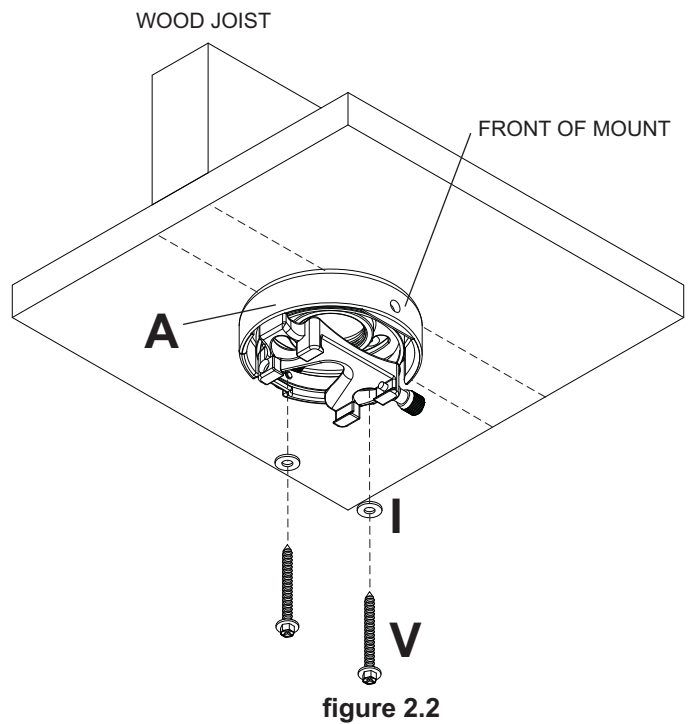

figure 2.2

## Installation to Concrete Ceilings

### ⚠ WARNING

- Concrete must be 2000 psi density minimum. Lighter density concrete may not hold concrete anchor.
- Make sure that the supporting surface will safely support the combined load of the equipment and all attached hardware and components.

**3**

Place projector mount assembly (**A**) on ceiling as a template and mark the center of the two mounting holes. Drill two 5/16" (8 mm) dia. holes to a minimum depth of 2.5" (64 mm). Attach projector mount assembly (**A**) using two concrete anchors (**W**), two flat washers (**I**), and two #14 x 2.5" wood screws (**V**) as shown.

**NOTE:** Mounting slots on projector mount assembly allow for 30° (±15°) of swivel adjustment before fully securing wood screw.

Tighten wood screws (**V**) using 3/8" (10 mm) socket wrench, phillips screwdriver until projector mount assembly (**A**) is firmly attached.

**Skip to step 6**

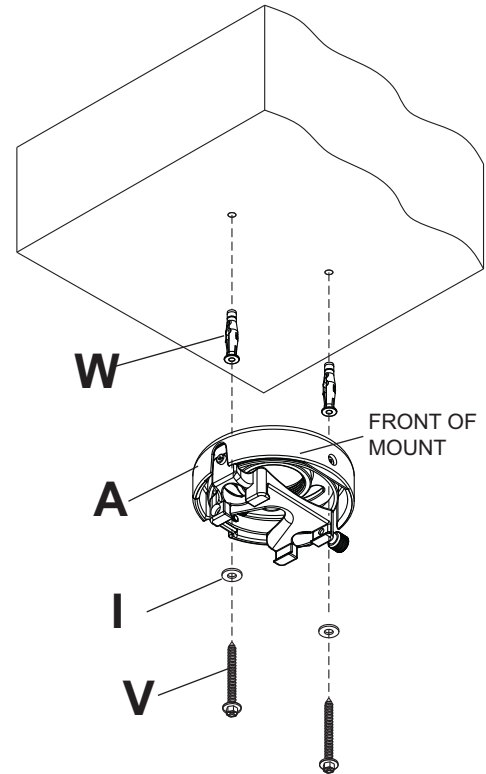

### ⚠ WARNING

- Tighten wood screws firmly, but do not overtighten. Overtightening can damage screws, greatly reducing their holding power.
- Never tighten in excess of 80 in. • lb (9 N.M.).
- Always attach concrete anchors directly to load-bearing concrete.
- Never attach concrete anchors to concrete covered with plaster, drywall, or other finishing material. If mounting to concrete surfaces covered with a finishing surface is unavoidable, the finishing surface must be counterbored as shown below. Be sure concrete anchors do not pull away from concrete when tightening screws. If plaster/drywall is thicker than 5/8", custom fasteners must be supplied by installer.

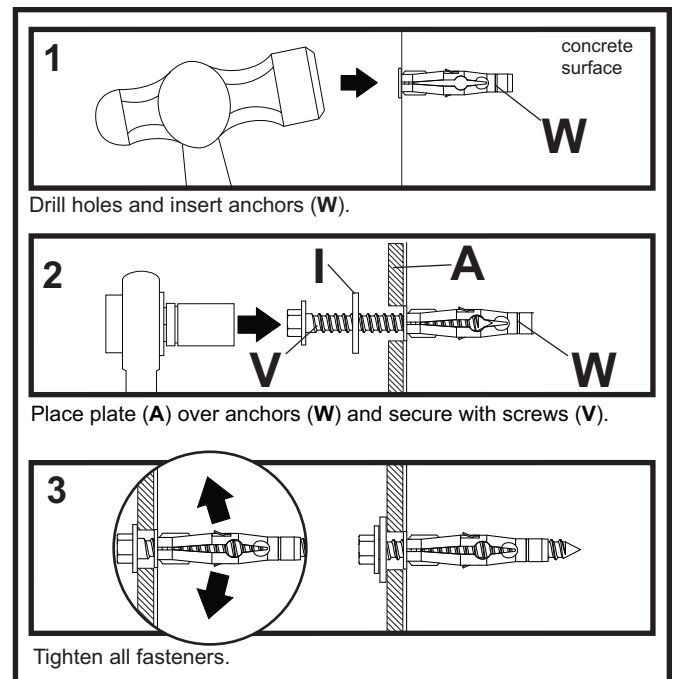
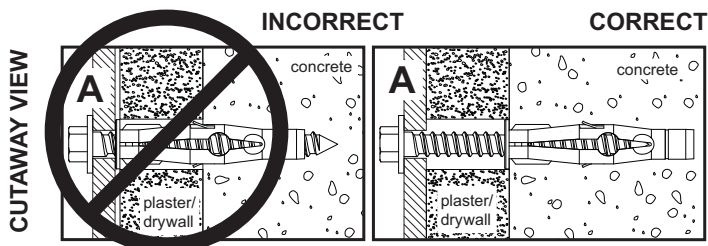

## Installation to Threaded Rod (Professional installation only)

- 4** Thread two 3/8-16 hex thin nylon-insert locknuts (not included) on two 3/8-16 threaded rods (not included) to the desired height of projector mount assembly. Attach projector mount assembly (A) to two 3/8-16 threaded rods using two 3/8-16 hex thin nylon-insert locknuts as shown in **figure 4.1** or **figure 4.2**.

**Skip to step 6.**

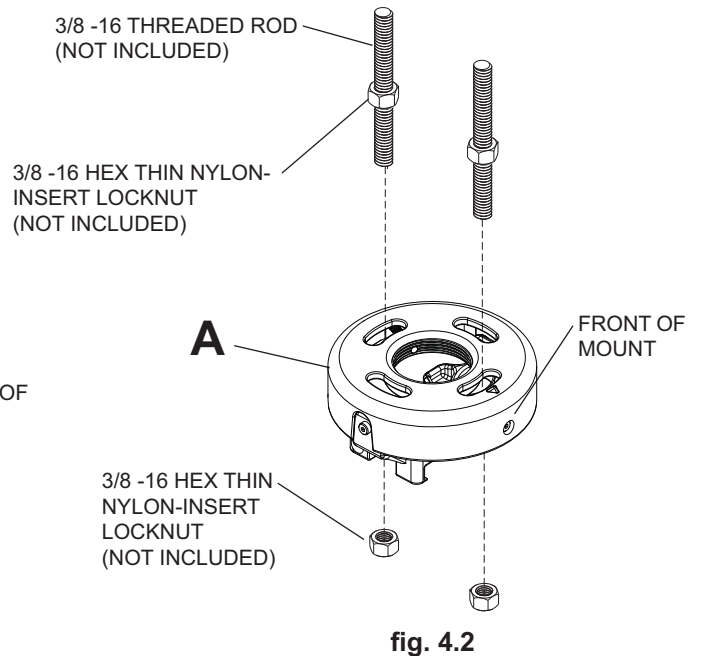
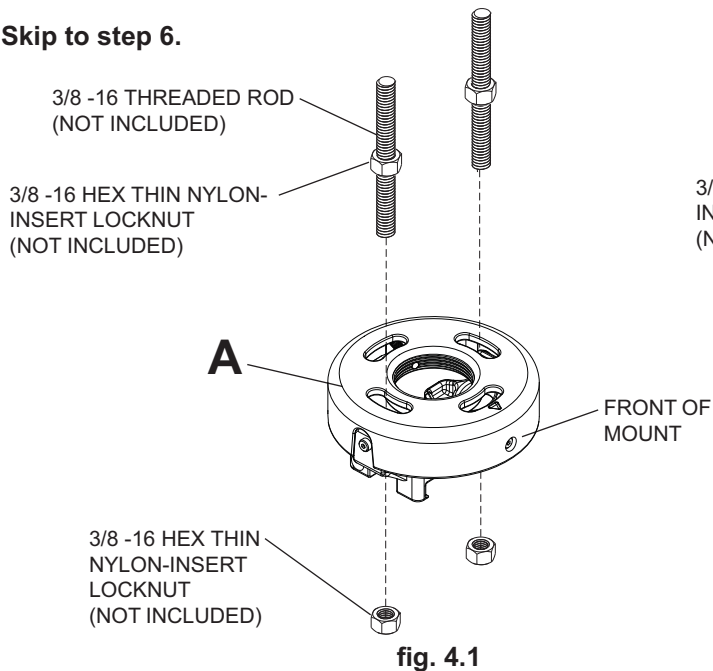

## Installation to Extension Column

- 5** Screw projector mount assembly (A) onto extension column (sold separately) as shown in **figure 5.1**. Tighten swivel stop screw against extension column or reducer using 4 mm allen wrench (T).

**NOTE:** Swivel stop screw is used to jam against threads of extension column or reducer to prevent any excess movement of projector mount assembly (A). Do not overtighten screw; overtightening screw will damage threads making it difficult to separate products.

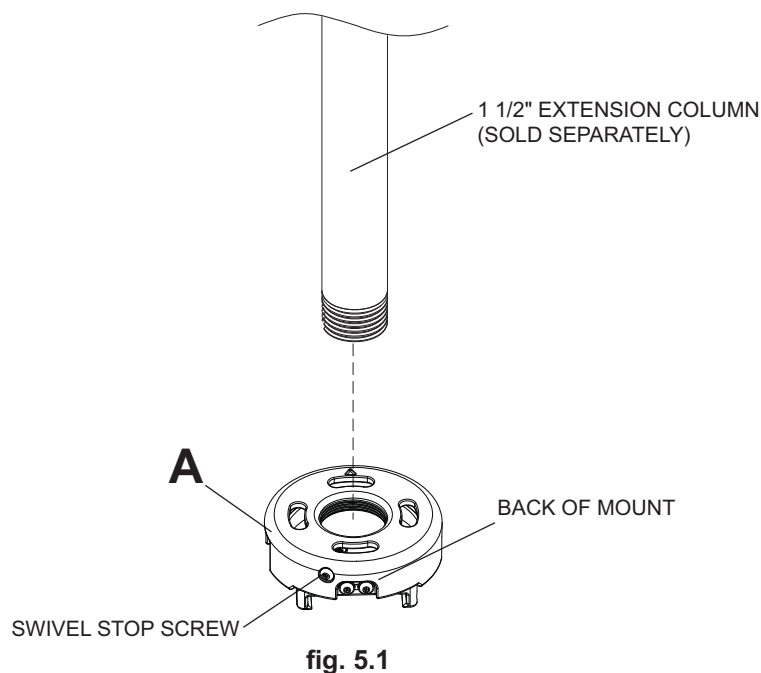

- 6** Open the mount and remove thumb screw (**D**) as shown. **NOTE:** The upper tray of the mount will now slide off of the lower tray.

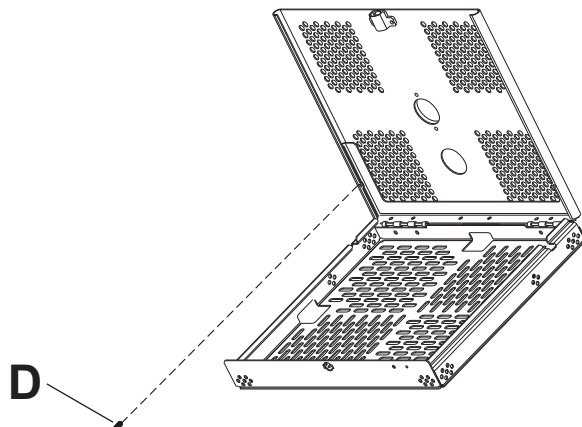

## Installation of Projector

- 7** Flip projector upside down. Attach lower tray to the bottom of the projector using appropriate number of screws (**K, L, M, N, O, P, Q, R or S**), washers (**I**) and spacers (**F**) as shown. Use 4 mm allen wrench (**T**) to tighten screws.

**IMPORTANT:** If projector does not have at least three mounting holes, do not use this tray assembly.

**NOTE:** Some projectors have feet which can be removed and the corresponding threaded insert can be used for a mounting hole.

**NOTE:** Projector may differ slightly in appearance.

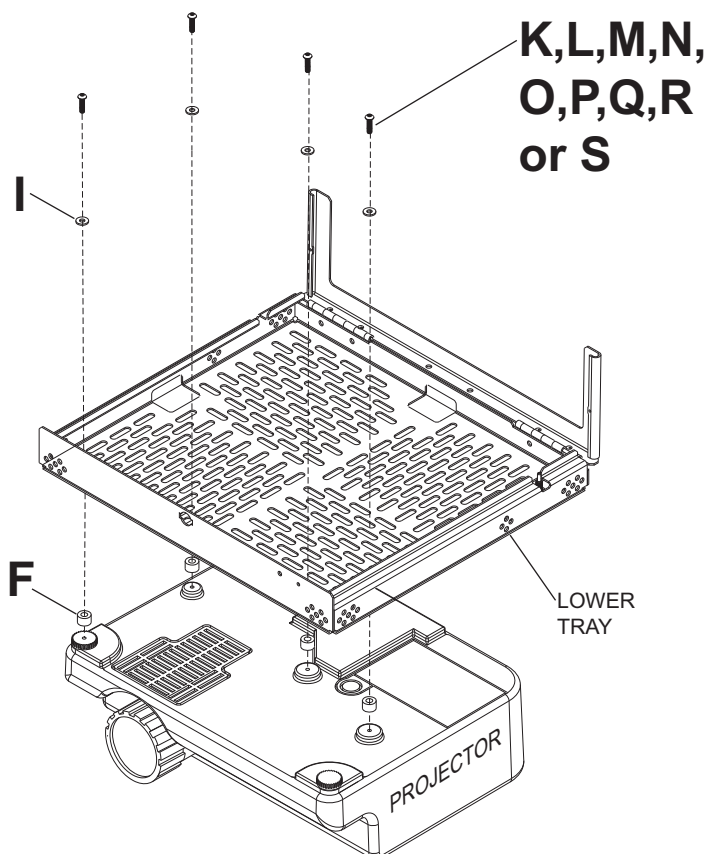



**8** Slide upper tray into the lower tray as shown.

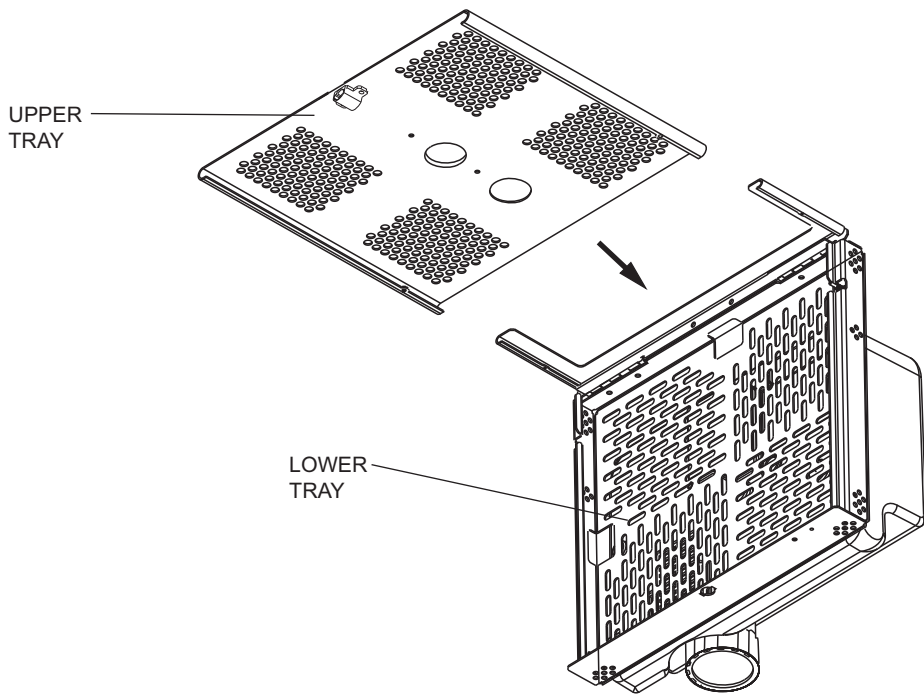

**9** Attach thumb screw (D) to mount as shown to lock the upper tray to the lower tray.

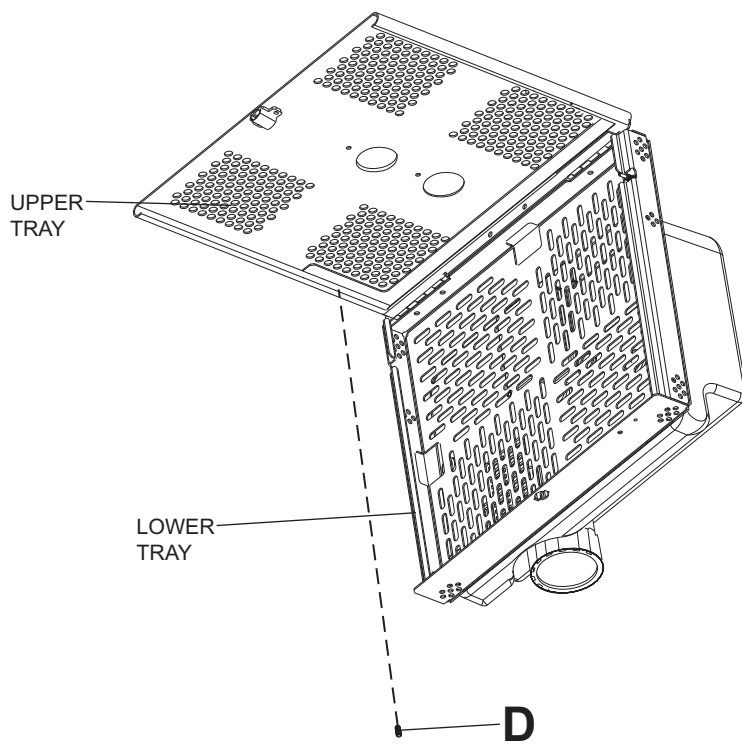

- 10** Close the mount and insert the lock plug (C) and key (X) as shown. Turn lock plug clockwise until tightly secure.  
**NOTE:** To remove key (X), key slot must be in the horizontal position. This may require that you back off 1/4 turn.

**IMPORTANT:** Key (X) is necessary for projector removal. Store it in a safe place.

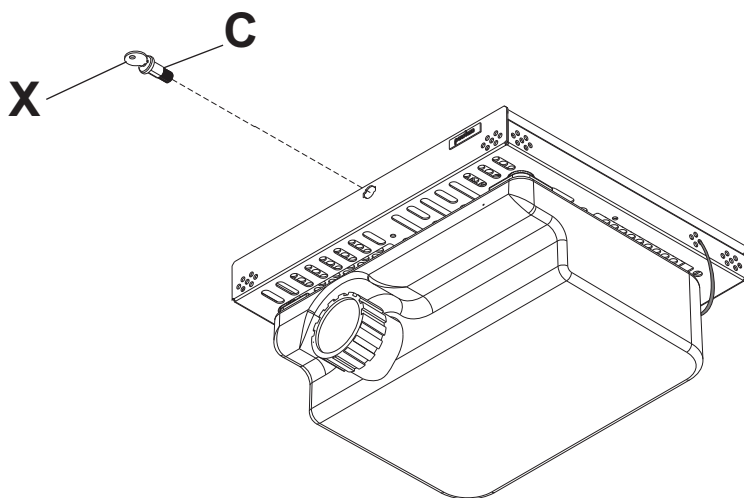

## ⚠ WARNING

- Do not lift more weight than you can handle! Use additional man power or mechanical lifting equipment to safely handle placement of the projector!

- 11** Slide connection block (Z) into projector mount assembly (A). Tighten captive screw to secure projector to projector mount assembly (A).

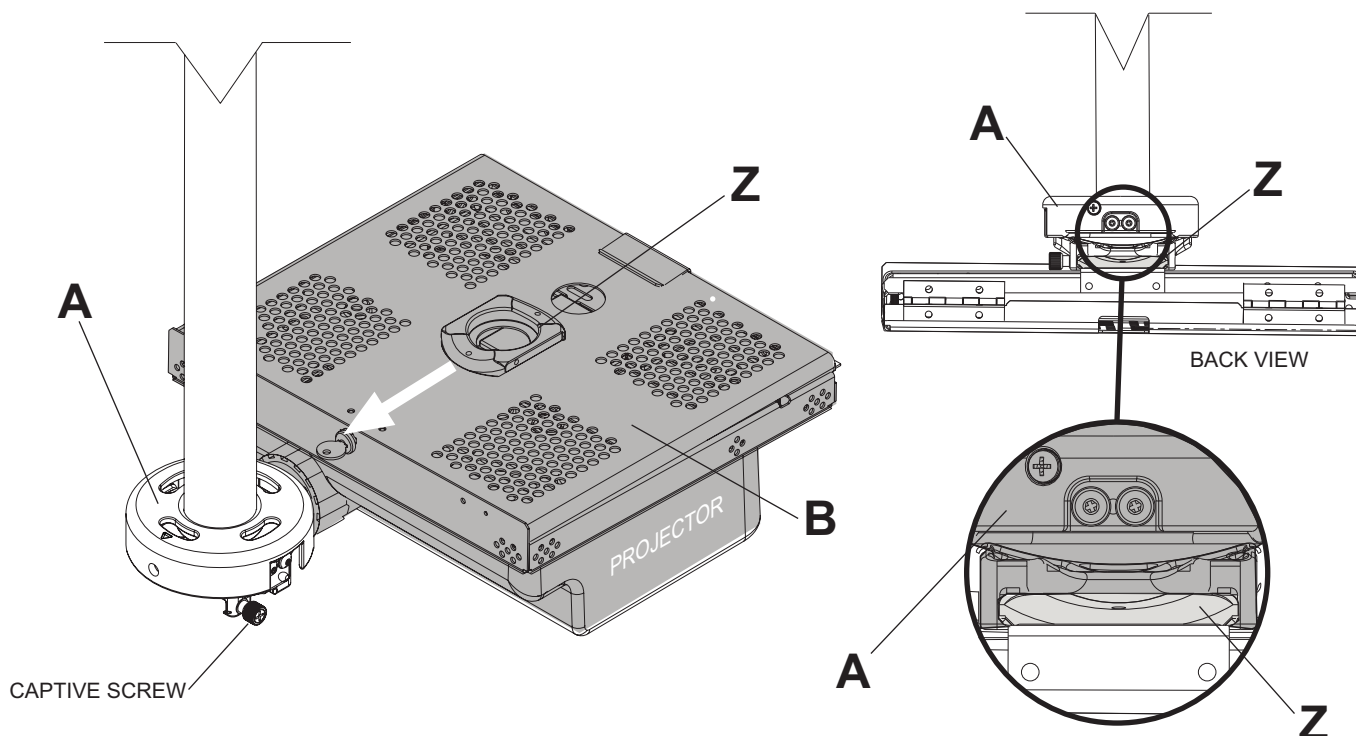

**12 IMPORTANT:** For security installations, insert one #10-32 socket pin screw (Y) through projector mount assembly (A) and into connection block (Z) as shown. Tighten screw with 4mm t-wrench (T).

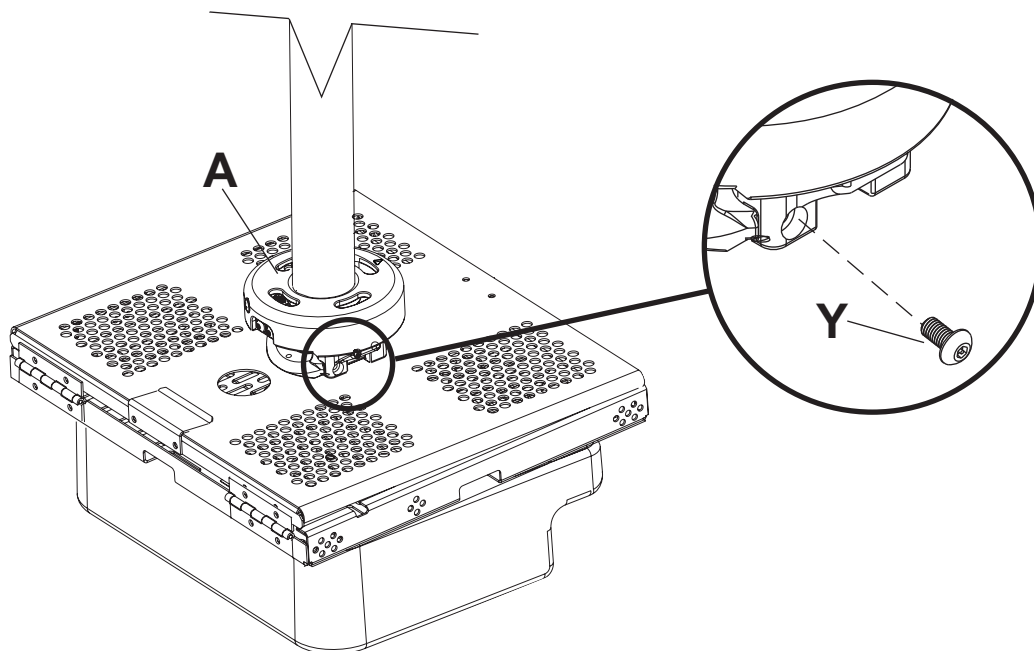

**13 To adjust yaw (swivel) for wood stud, concrete ceiling, and threaded rod mounting applications:** Loosen wood screws (V), or locknuts for threaded rods, until projector mount can be rotated. Rotate mount to desired position and retighten screws or locknuts.

**To adjust yaw (swivel) for extension column applications:** Loosen screw on projector mount assembly (A) indicated below until projector mount can be rotated. Rotate mount to desired position and retighten screw.

**To adjust pitch (forward and backward tilt):** Loosen two screws on projector mount assembly (A) indicated below. Tilt mount to desired position and retighten screws.

**To adjust roll (side to side tilt):** Loosen two screws on projector mount assembly (A) indicated below. Tilt mount to desired position and retighten screws.

