

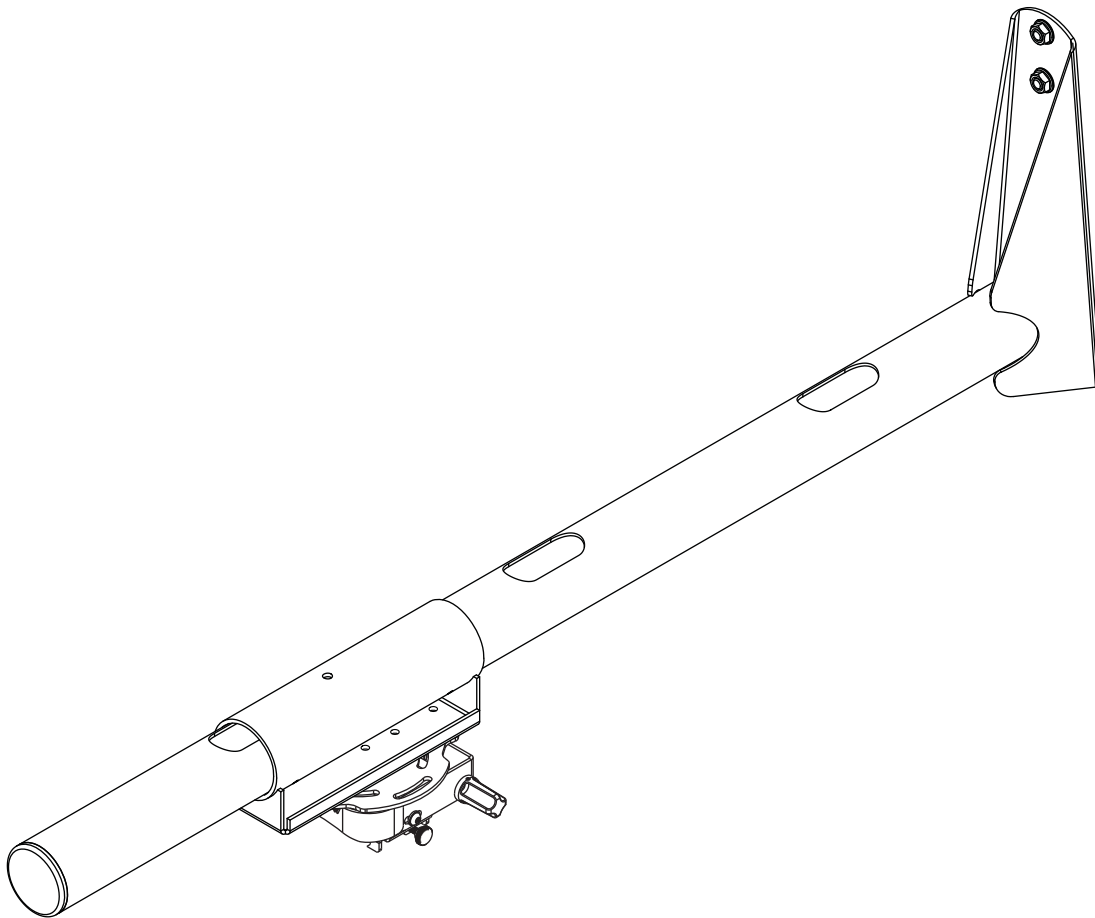

205 Westwood Ave, Long Branch, NJ 07740
Phone: 866-94 BOARDS (26273) / (732)-222-1511
Fax: (732)-222-7088 | E-mail: sales@touchboards.com

Installation and Assembly: Universal Projector Wall Arm

Models: PSTA-028, PSTA-028-W, PSTK-028, PSTK-028-W



Max UL Load Capacity: 50 lb (22.7 kg)

Note: Read entire instruction sheet before you start installation and assembly.

⚠ WARNING

- Do not begin to install your Peerless product until you have read and understood the instructions and warnings contained in this Installation Sheet. If you have any questions regarding any of the instructions or warnings, for US customers please call Peerless customer care at 1-800-865-2112, for all international customers, please contact your local distributor.
- This product should only be installed by someone of good mechanical aptitude, has experience with basic building construction, and fully understands these instructions.
- Make sure that the supporting surface will safely support the combined load of the equipment and all attached hardware and components.
- Never exceed the Maximum Load Capacity. See page one.
- If mounting to wood wall studs, make sure that mounting screws are anchored into the center of the studs. Use of an "edge to edge" stud finder is highly recommended.
- Always use an assistant or mechanical lifting equipment to safely lift and position equipment.
- Tighten screws firmly, but do not overtighten. Overtightening can damage the items, greatly reducing their holding power.
- This product is intended for indoor use only. Use of this product outdoors could lead to product failure and personal injury.
- This product was designed to be installed on the following wall construction only;

WALL CONSTRUCTION

HARDWARE REQUIRED

- | | |
|--------------------|--|
| • Wood Stud | Included |
| • Wood Beam | Included |
| • Solid Concrete | Included |
| • Cinder Block | Included |
| • Metal Stud | Contact Qualified Professional (not evaluated by UL) |
| • Brick | Contact Qualified Professional (not evaluated by UL) |
| • Other or unsure? | Contact Qualified Professional (not evaluated by UL) |

Tools Needed for Assembly

- stud finder ("edge to edge" stud finder recommended)
- level
- drill
- 5/32" drill bit for wood studs
- 5/16" dill bit for solid concrete and cinder block
- phillips screwdriver

Accessories

- ACC-MIS550 (not evaluated by UL)
(cable accessory kit)
- ACC020 (not evaluated by UL)
(Projector Security Cable kit)
- WBK100 (not evaluated by UL)
(wall plate accessory kit)

Table of Contents

Parts List.....	3
Installation to Wood Stud.....	4,6
Installation to Solid Concrete/Cinder Block	5,7
Assembly of Adjustment Tube	8
Installing Projector Mount	8
Routing Cables.....	9

IMPORTANT: Read instruction sheet before you start installation and assembly.

Before you start check the parts list to insure all of the parts shown are included.

Parts List		PSTA-028	PSTA-028-W	PSTK-028	PSTK-028-W
Description	Qty	Part #	Part #	Part #	Part #
A wall arm	1	055-1909	055-2909	055-1909	055-2909
B carriage	1	056-1332	056-2332	056-1332	056-2332
C 4 mm allen wrench	1	560-9646	560-9646	560-9646	560-9646
D M5 x 10 mm serrated socket pin screw	4	520-1063	520-2063	520-1063	520-2063
E #14- x 2.5 phillips head wood screw	4	5S1-015-C03	5S1-015-C04	5S1-015-C03	5S1-015-C04
F tube cap	1	590-1274	590-1274	590-1274	590-1274
G concrete anchor	4	590-0320	590-0320	590-0320	590-0320
H 1/4"-20 phillips screw	2	520-1054	520-2069	520-1054	520-2069
I 1/4"-20 flat washer	2	540-1078	540-2078	540-1078	540-2078
J projector mount	1	PRGS-UNV	PRGS-UNV-W	PRGS-UNV	PRGS-UNV-W
K wall plate	1	—	—	055-1923	055-2923
L 5/16 -18 x 1/2 carriage bolt	4	—	—	520-9207	520-2047
M 5/16 - 18 serrated flanged lock nut	4	—	—	530-1016	530-2016

NOTE: Some parts may appear slightly different than illustrated.

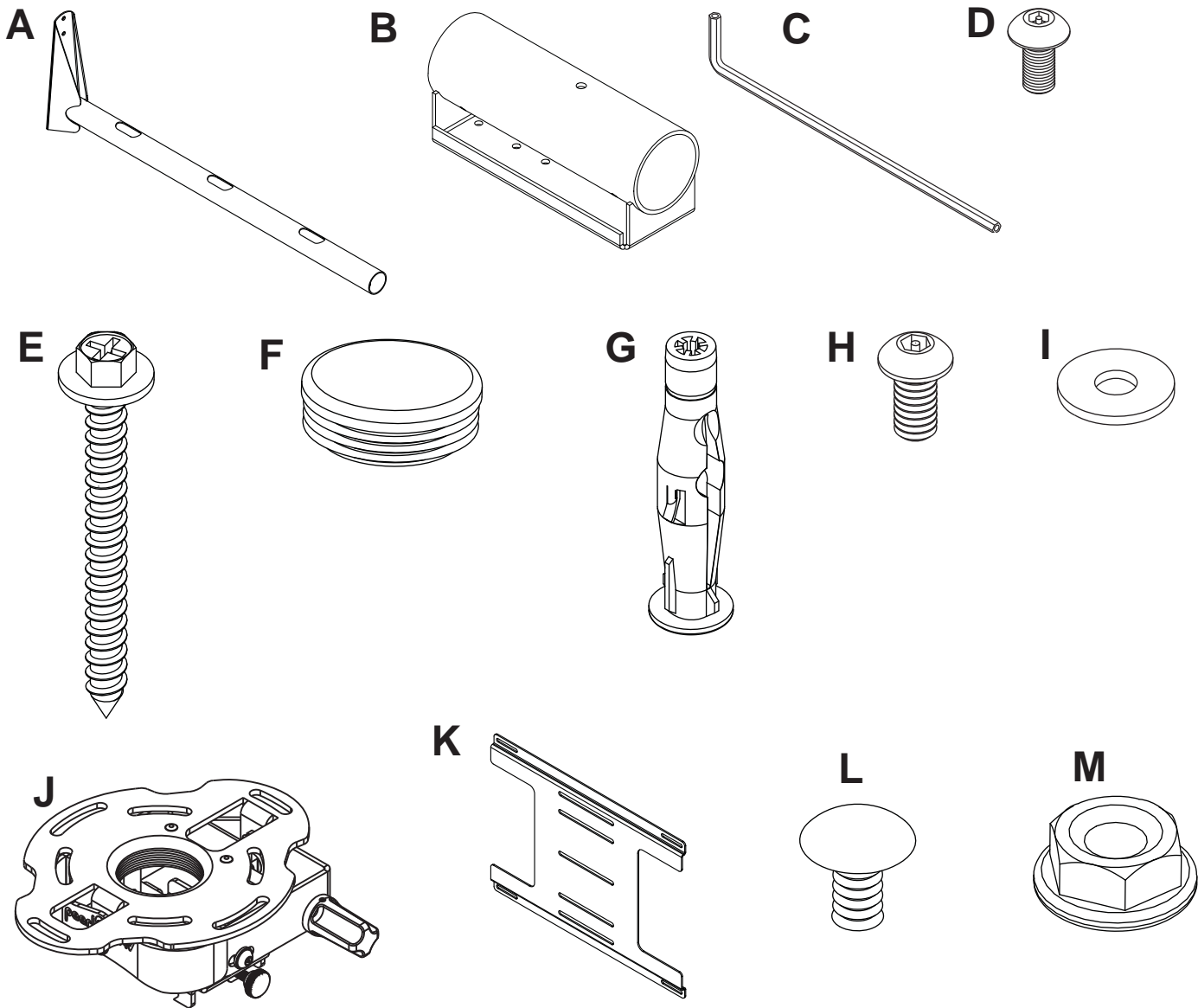

Installation to Wood Stud Walls for PSTA-028, PSTA-028-W Models

▲ WARNING

- Installer must verify that the supporting surface will safely support the combined load of the equipment and all attached hardware and components.
- Tighten wood screws so that wall plate is firmly attached, but do not overtighten. Overtightening can damage the screws, greatly reducing their holding power.
- Never tighten in excess of 80 in. • lb (9 N.M.).
- Make sure that mounting screws are anchored into the center of the stud. The use of an "edge to edge" stud finder is highly recommended.
- Hardware provided is for attachment of mount through standard thickness drywall or plaster into wood studs. Installers are responsible to provide hardware for other types of mounting situations (not evaluated by UL).

1 **Note:** For PSTK-028 models, refer to page 6.

Use a stud finder to locate the edges of the stud. Use of an edge-to-edge stud finder is highly recommended. Based on its edges, draw a vertical line down the stud's center. Place wall arm (A) on wall as a template. Mark the center of the four mounting holes. Drill four 5/32" (4 mm) dia. holes 2-1/2" (65 mm) deep. Secure wall arm (A) to wood stud using four #14 x 2-1/2" wood screws (E) as shown.

Optional: Rotate wall arm 180° to position the arm closer to the ceiling.

Skip to Step 2.

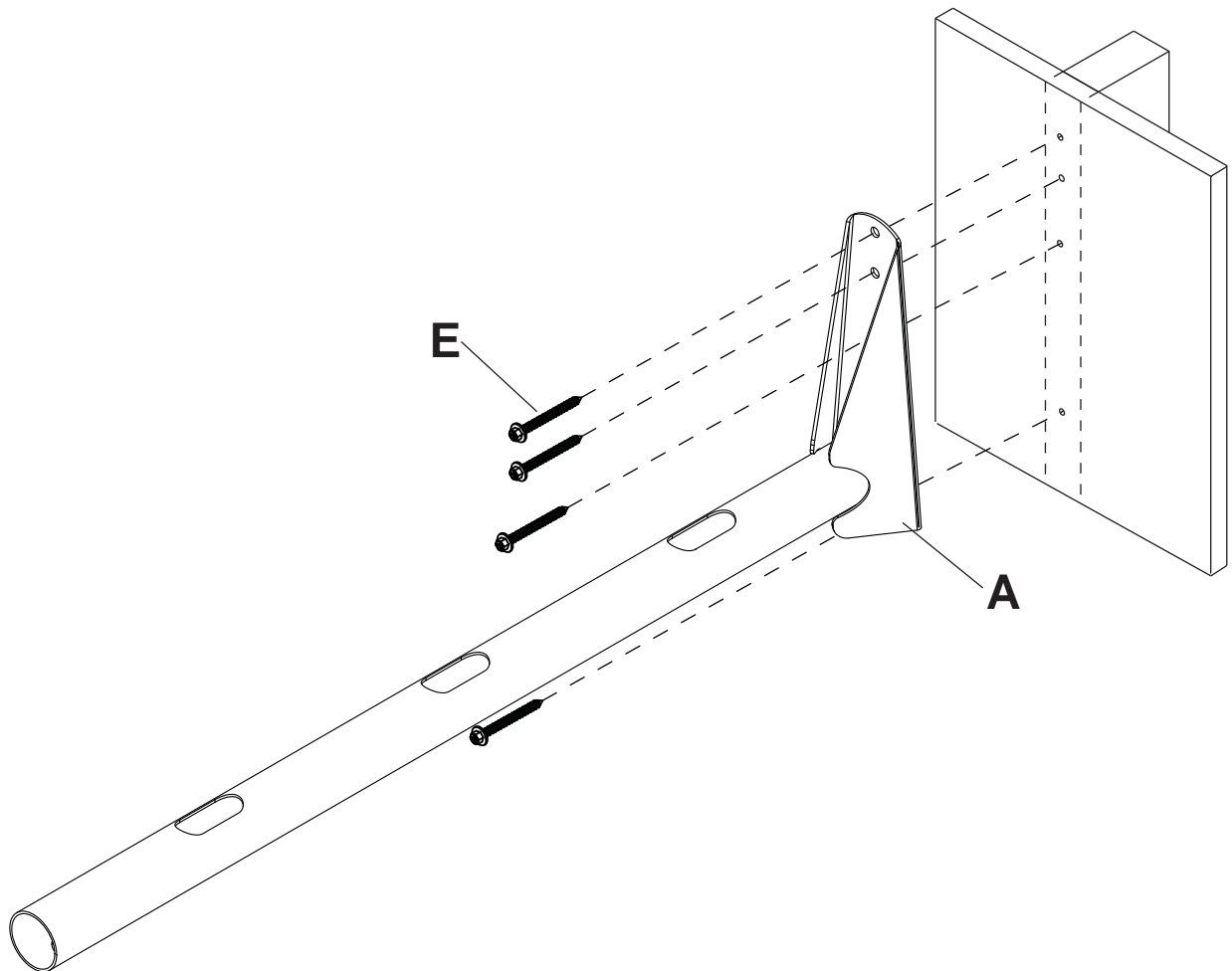

Installation to Solid Concrete or Cinder Block Wall for PSTA-028, PSTA-028-W Models

⚠ WARNING

- When installing Peerless wall mounts on cinder block, verify that you have a minimum of 1-3/8" of actual concrete surface in the hole to be used for the concrete anchors. Do not drill into mortar joints! Be sure to mount in a solid part of the block, generally 1" minimum from the side of the block. Cinder block must meet ASTM C-90 specifications. It is suggested that a standard electric drill on slow setting is used to drill the hole instead of a hammer drill to avoid breaking out the back of the hole when entering a void or cavity.
- Concrete must be 2000 psi density minimum. Lighter density concrete may not hold concrete anchor.
- Make sure that the wall will safely support four times the combined load of the equipment and all attached hardware and components.

- 1** **Note:** For PSTK-028 models, refer to page 6.
- Drill four 5/16" (8 mm) dia. holes to a minimum depth of 2.5" (64 mm). Insert anchors (**G**) in holes flush with wall as shown. Attach wall arm (**A**) using four #14 x 2 -1/2" wood screws (**E**) as shown in **Illustration A** and **1, 2, and 3**. Tighten all fasteners. **Optional:** Rotate wall arm 180° to position the arm closer to the ceiling.
- Skip to Step 2.

⚠ WARNING

- Tighten wood screws firmly, but do not overtighten. Overtightening can damage the screws, greatly reducing their holding power.
- Never tighten in excess of 80 in • lb (9 N.M.).

⚠ WARNING

- Concrete anchors are **not** intended for attachment to concrete wall covered with a layer of plaster, drywall, or other finishing material. If mounting to concrete wall covered with plaster/drywall is unavoidable (not evaluated by UL), plaster/drywall (up to 5/8" thick) must be counterbored as shown right. If plaster/drywall is thicker than 5/8", custom fasteners must be supplied by installer (not evaluated by UL).

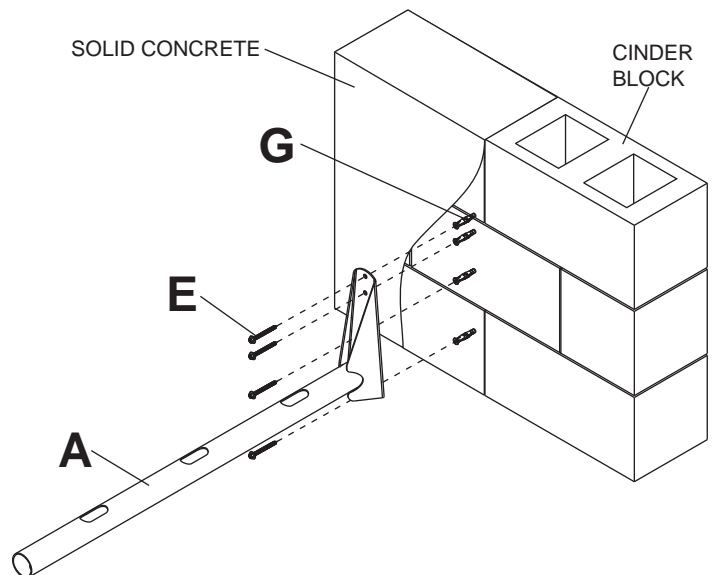
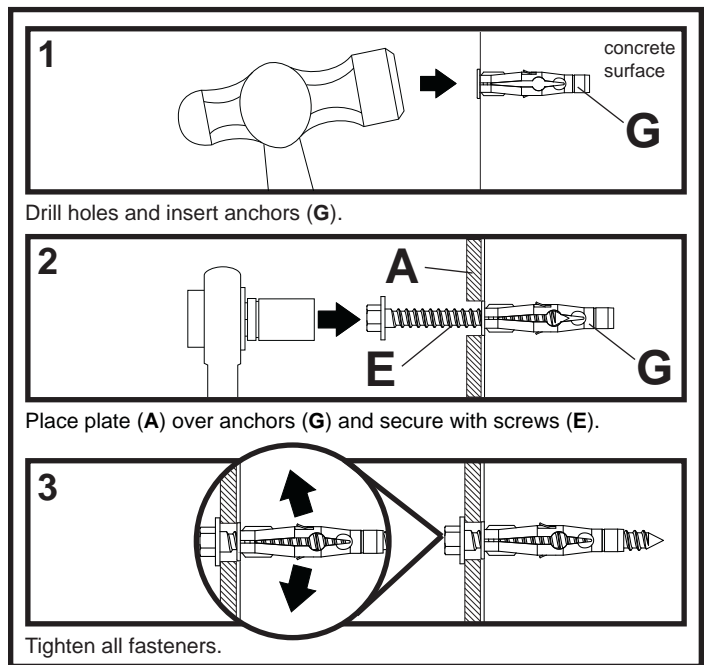
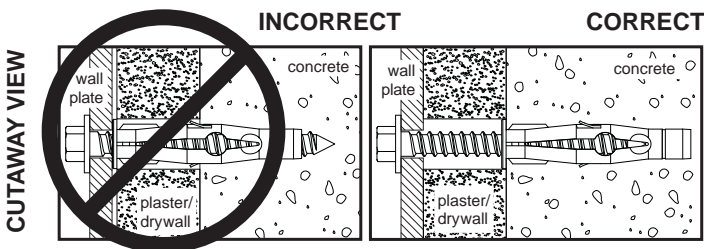
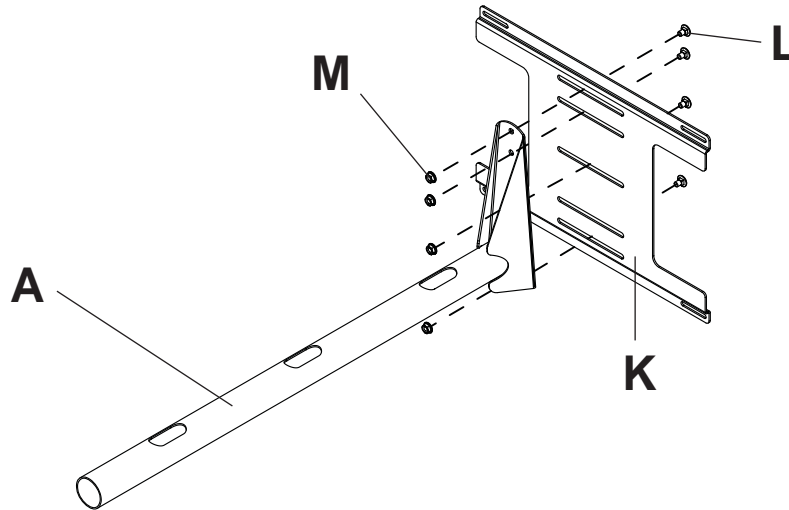

Illustration A

Installation to Wall Plate For PSTK-028, PSTK-028-W Models

1

Secure wall arm (A) to wall plate (K) using four carriage bolts (L) and lock nuts (M).



Installation to Wood Stud Wall for PSTK-028, PSTK-028-W

⚠ WARNING

- Installer must verify that the supporting surface will safely support the combined load of the equipment and all attached hardware and components.
- Tighten wood screws so that wall plate is firmly attached, but do not overtighten. Overtightening can damage the screws, greatly reducing their holding power.
- Never tighten in excess of 80 in. • lb (9 N.M.).
- Make sure that mounting screws are anchored into the center of the stud. The use of an "edge to edge" stud finder is highly recommended.
- Hardware provided is for attachment of mount through standard thickness drywall or plaster into wood studs. Installers are responsible to provide hardware for other types of mounting situations (not evaluated by UL).

1-1

Use a stud finder to locate the edges of the stud. Use of an edge-to-edge stud finder is highly recommended. Based on its edges, draw a vertical line down the stud's center. Place wall plate (K) on wall as a template. Mark the center of the four mounting holes. Drill four 5/32" (4 mm) dia. holes 2-1/2" (65 mm) deep. Secure wall plate (K) to wood stud using four #14 x 2-1/2" wood screws (E) as shown.

Optional: Rotate wall arm 180° to position the arm closer to the ceiling.

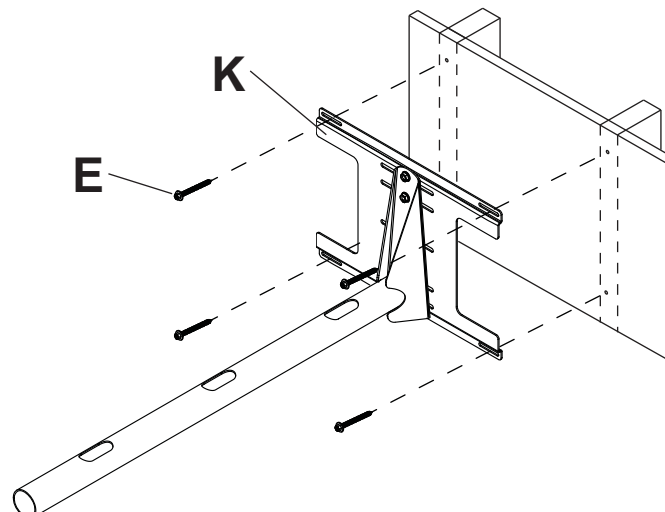

Installation to Solid Concrete or Cinder Block Wall for PSTK-028, PSTK-028-W

▲ WARNING

- When installing Peerless wall mounts on cinder block, verify that you have a minimum of 1-3/8" of actual concrete surface in the hole to be used for the concrete anchors. Do not drill into mortar joints! Be sure to mount in a solid part of the block, generally 1" minimum from the side of the block. Cinder block must meet ASTM C-90 specifications. It is suggested that a standard electric drill on slow setting is used to drill the hole instead of a hammer drill to avoid breaking out the back of the hole when entering a void or cavity.
- Concrete must be 2000 psi density minimum. Lighter density concrete may not hold concrete anchor.
- Make sure that the wall will safely support four times the combined load of the equipment and all attached hardware and components.

- 1** Drill four 5/16" (8 mm) dia. holes to a minimum depth of 2.5" (64 mm). Insert anchors (**G**) in holes flush with wall as shown. Attach wall plate (**K**) using four #14 x 2 -1/2" wood screws (**E**) as shown in **Illustration A** and **1, 2, and 3**. Tighten all fasteners.

Optional: Rotate wall arm 180° to position the arm closer to the ceiling.

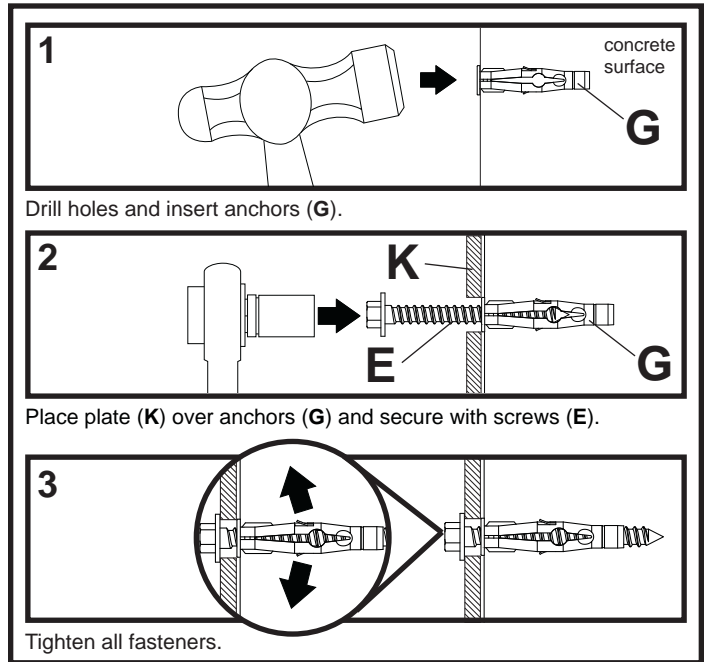

▲ WARNING

- Tighten wood screws firmly, but do not overtighten. Overtightening can damage the screws, greatly reducing their holding power.
- Never tighten in excess of 80 in • lb (9 N.M.).

▲ WARNING

- Concrete anchors are **not** intended for attachment to concrete wall covered with a layer of plaster, drywall, or other finishing material. If mounting to concrete wall covered with plaster/drywall is unavoidable (not evaluated by UL), plaster/drywall (up to 5/8" thick) must be counterbored as shown right. If plaster/drywall is thicker than 5/8", custom fasteners must be supplied by installer (not evaluated by UL).

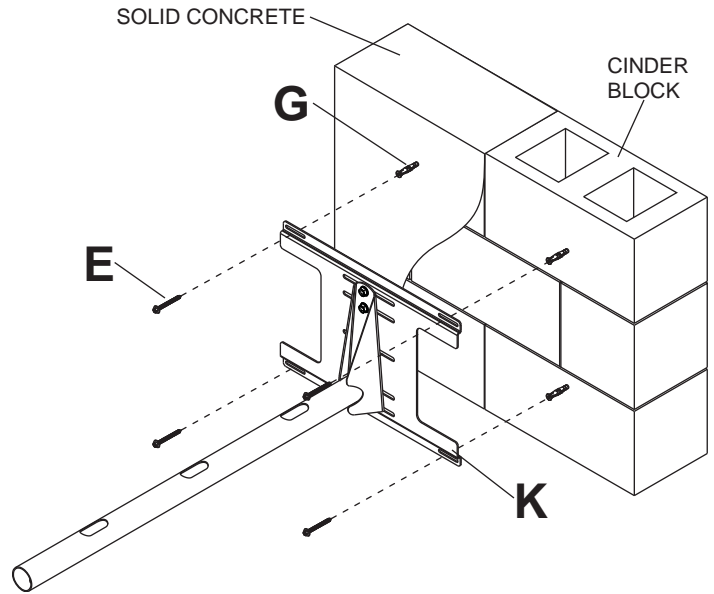
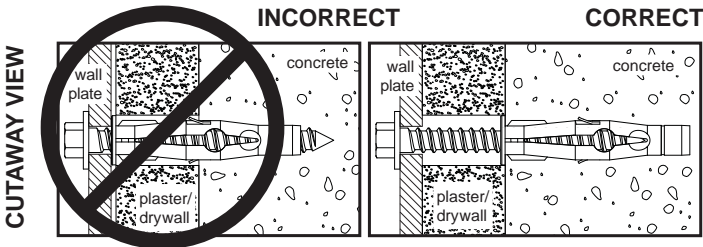
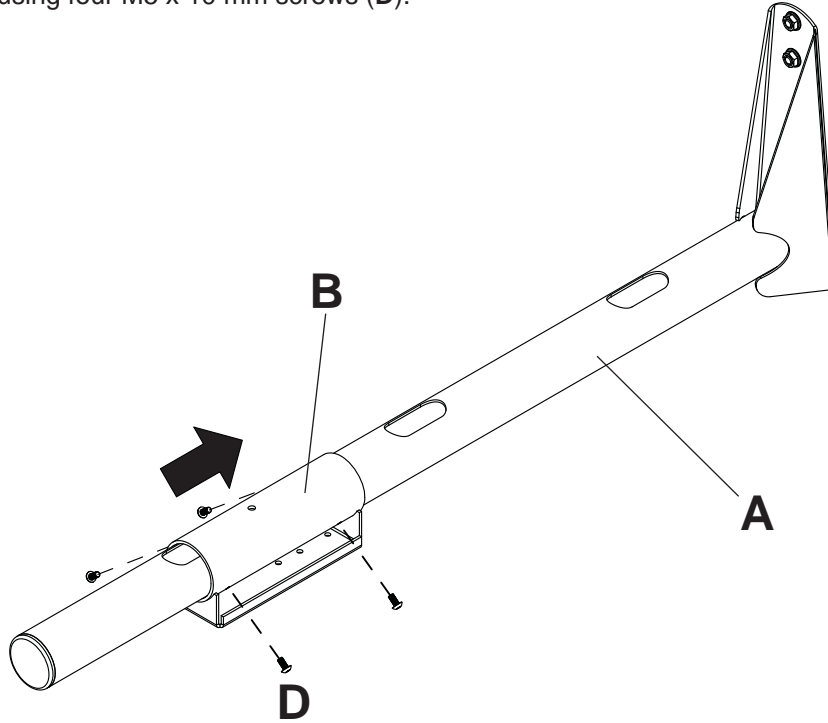

Illustration A

Assembly of Adjustment Tube

- 2 Slide carriage (B) over wall arm (A) and adjust to the desired projector throw distance as shown. Lock carriage (B) into place using four M5 x 10 mm screws (D).



Installing PRGS Projector Mount

- 3 **Installing PRGS projector mount to wall arm assembly:** Attach PRGS projector mount (J) to carriage (B) using two 1/4-20 phillips screws (H) and two flat washers (I) as shown below.

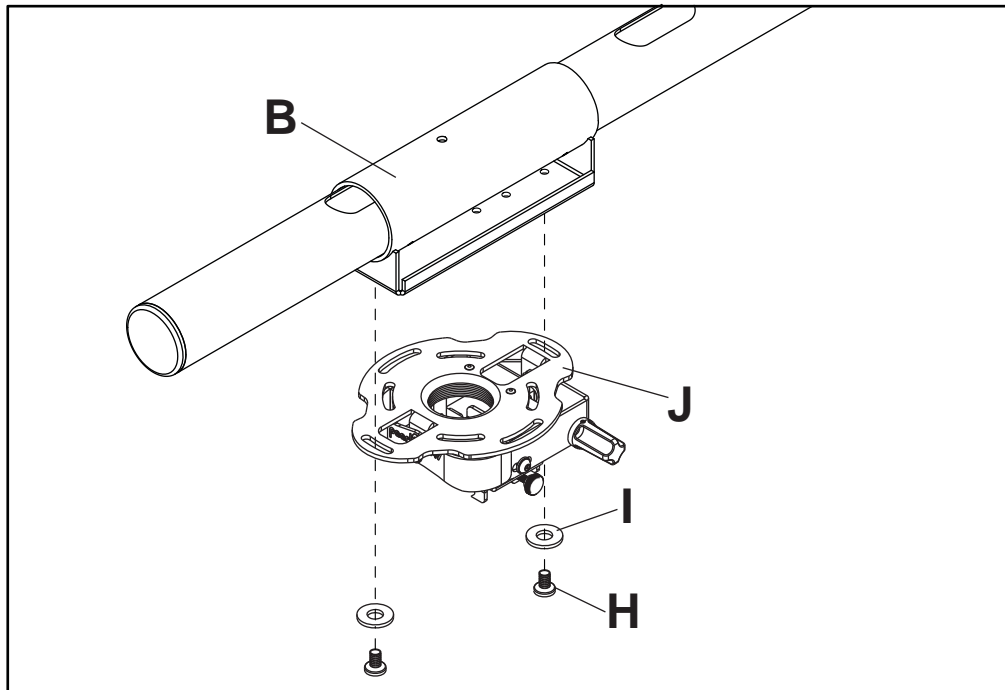

Routing Cables

- 4 Routing Cables through PRGS projector mount and wall arm assembly:** Guide projector cables into openings in projector mount and wall arm assembly as shown below. Insert Tube Cap (F) into end of wall arm (A).
- Note:** Cables must be removed from projector before routing through wall arm.
- Note:** Follow projector mount (PRGS) instructions to install projector.

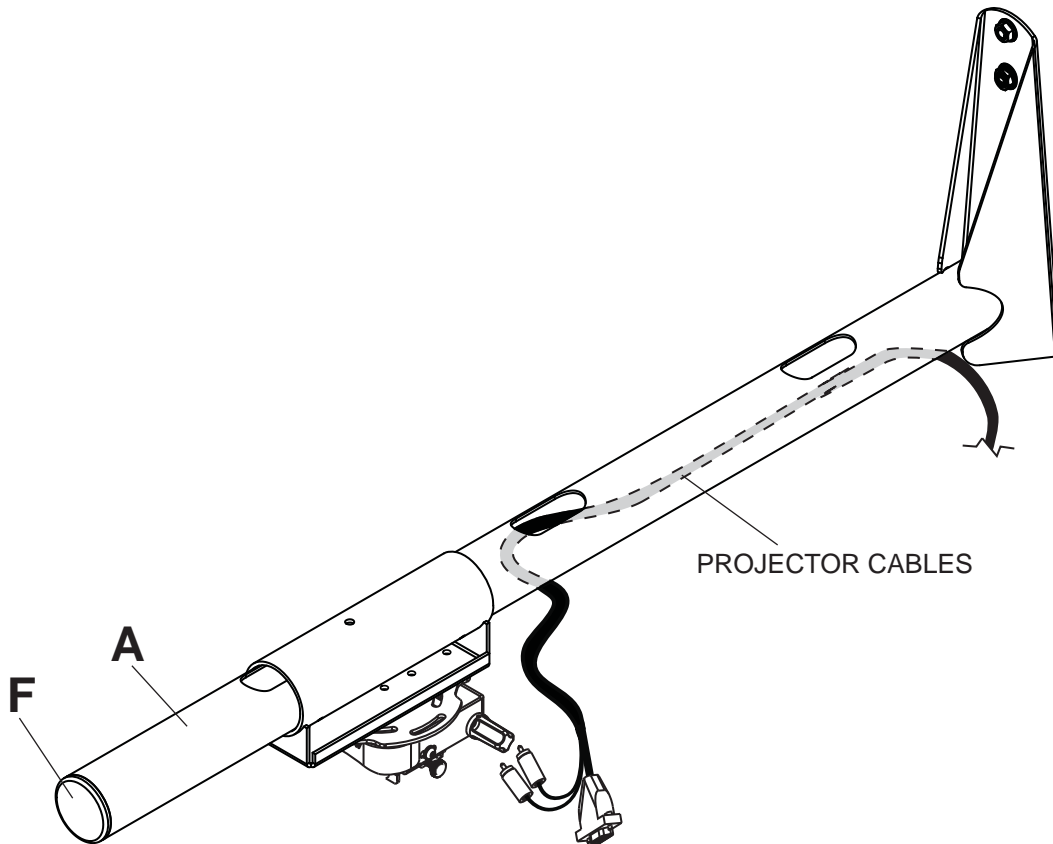

Touchboards

205 Westwood Ave, Long Branch, NJ 07740
Phone: 866-94 BOARDS (26273) / (732)-222-1511
Fax: (732)-222-7088 | E-mail: sales@touchboards.com